



HYDRAULIC POWER CONTROL

## Proportional Directional valves series: PDV74 - PDV114 - PDV315 Hydraulic remote controls



Алматы (7273)495-231  
Ангарск (3955)60-70-56  
Архангельск (8182)63-90-72  
Астрахань (8512)99-46-04  
Барнаул (3852)73-04-60  
Белгород (4722)40-23-64  
Благовещенск (4162)22-76-07  
Брянск (4832)59-03-52  
Владивосток (423)249-28-31  
Владикавказ (8672)28-90-48  
Владимир (4922)49-43-18  
Волгоград (844)278-03-48  
Вологда (8172)26-41-59  
Воронеж (473)204-51-73  
Екатеринбург (343)384-55-89

Россия +7(495)268-04-70

Иваново (4932)77-34-06  
Ижевск (3412)26-03-58  
Иркутск (395)279-98-46  
Казань (843)206-01-48  
Калининград (4012)72-03-81  
Калуга (4842)92-23-67  
Кемерово (3842)65-04-62  
Киров (8332)68-02-04  
Коломна (4966)23-41-49  
Кострома (4942)77-07-48  
Краснодар (861)203-40-90  
Красноярск (391)204-63-61  
Курск (4712)77-13-04  
Курган (3522)50-90-47  
Липецк (4742)52-20-81

Магнитогорск (3519)55-03-13  
Москва (495)268-04-70  
Мурманск (8152)59-64-93  
Набережные Челны (8552)20-53-41  
Нижегород (831)429-08-12  
Новокузнецк (3843)20-46-81  
Ноябрьск (3496)41-32-12  
Новосибирск (383)227-86-73  
Омск (3812)21-46-40  
Орел (4862)44-53-42  
Оренбург (3532)37-68-04  
Пенза (8412)22-31-16  
Петрозаводск (8142)55-98-37  
Псков (8112)59-10-37  
Пермь (342)205-81-47

Казахстан +7(7172)727-132

Ростов-на-Дону (863)308-18-15  
Рязань (4912)46-61-64  
Самара (846)206-03-16  
Санкт-Петербург (812)309-46-40  
Саратов (845)249-38-78  
Севастополь (8692)22-31-93  
Саранск (8342)22-96-24  
Симферополь (3652)67-13-56  
Смоленск (4812)29-41-54  
Сочи (862)225-72-31  
Ставрополь (8652)20-65-13  
Сургут (3462)77-98-35  
Сыктывкар (8212)25-95-17  
Тамбов (4752)50-40-97  
Тверь (4822)63-31-35

Киргизия +996(312)96-26-47

Тольятти (8482)63-91-07  
Томск (3822)98-41-53  
Тула (4872)33-79-87  
Тюмень (3452)66-21-18  
Ульяновск (8422)24-23-59  
Улан-Удэ (3012)59-97-51  
Уфа (347)229-48-12  
Хабаровск (4212)92-98-04  
Чебоксары (8352)28-53-07  
Челябинск (351)202-03-61  
Череповец (8202)49-02-64  
Чита (3022)38-34-83  
Якутск (4112)23-90-97  
Ярославль (4852)69-52-93

INTRODUZIONE

OMFB Hydraulic Components produces a full range of hand grips designed for use on working vehicles in earthmoving applications, on building sites, and also in the farming industry.

To find the right grip for each application, the characteristics and a standard configurations are indicated for each one.

For special applications or configuration, please contact our offices



S

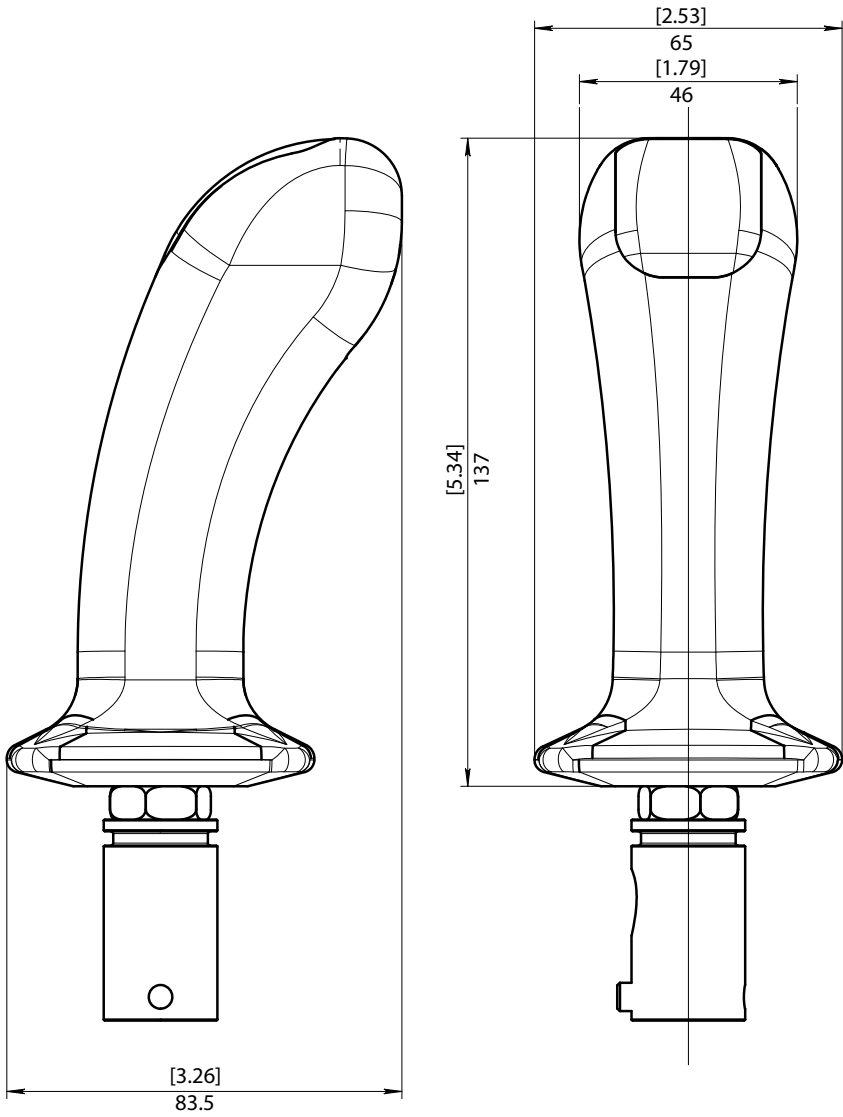

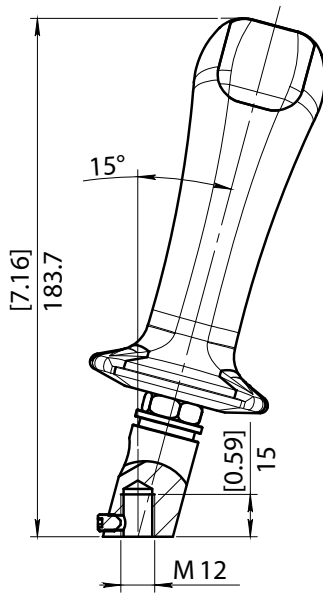

1

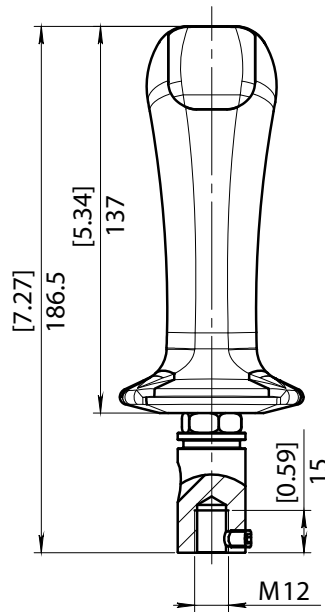

2

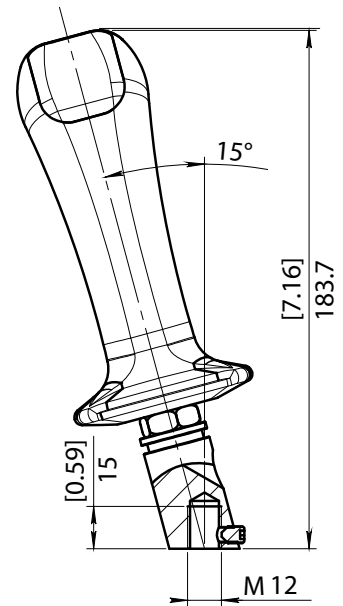

3

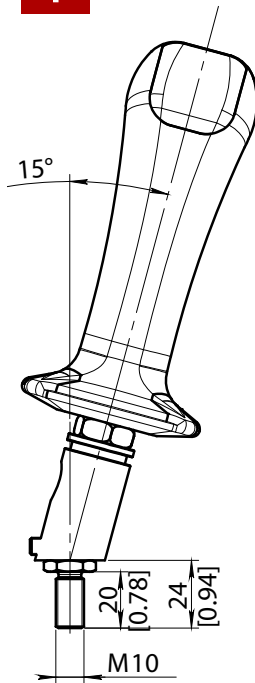

4

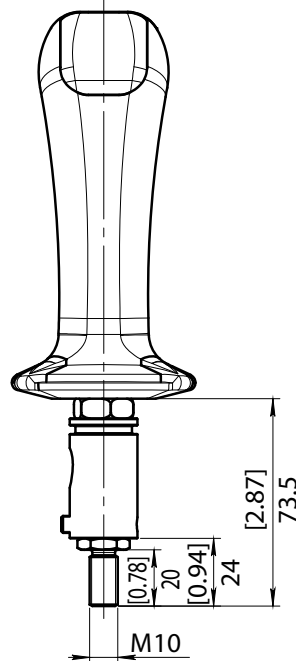

5

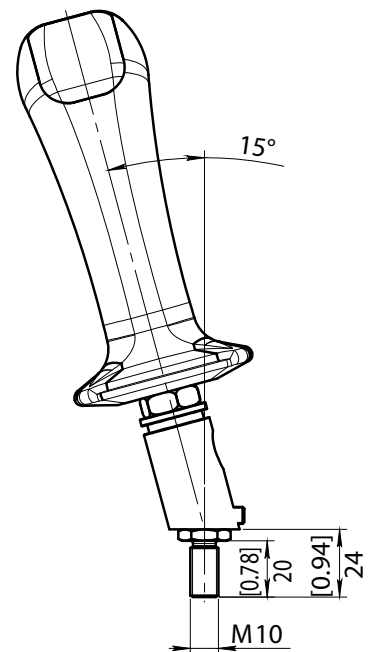

6

1 RIGHT TILTED 15° M12

2 STRAIGHT M12

3 LEFT TILTED 15° M12

4 RIGHT TILTED 15° M10

5 STRAIGHT M10

6 LEFT TILTED 15° M10

TOP CONFIGURATIONS

FRONT CONFIGURATIONS

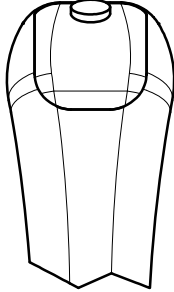
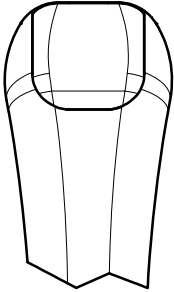

**M1**

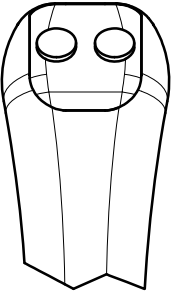

**M2+M3**

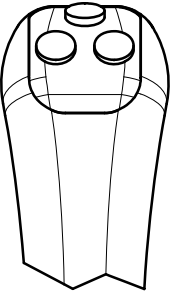

**M1+M2+M3**

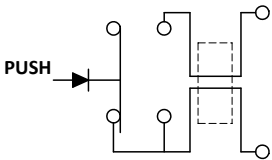

MICRO CAPACITY: DC 12V x 2A

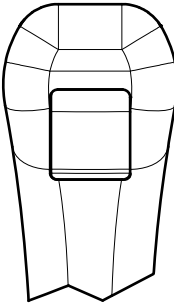

**M4: Spring back**

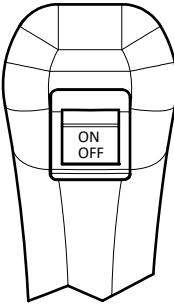
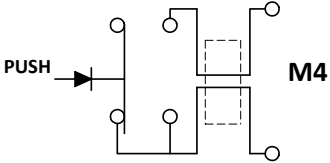

**M4: On / Off**

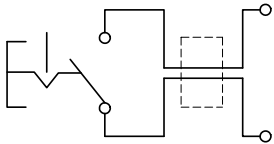

**M4 On / Off**

MICRO CAPACITY: DC 12V x 2A

**0** NO TOP BUTTON

**1** M1

**2** M2+M3

**3** M1+M2+M3

**0** NO M4 BUTTON

**1** 1 FRONT SWITCH M4 WITH ROCKING LEVER WITH SPRING RETURN-TO-CENTRE

**2** M4 ON/OFF SWITCH

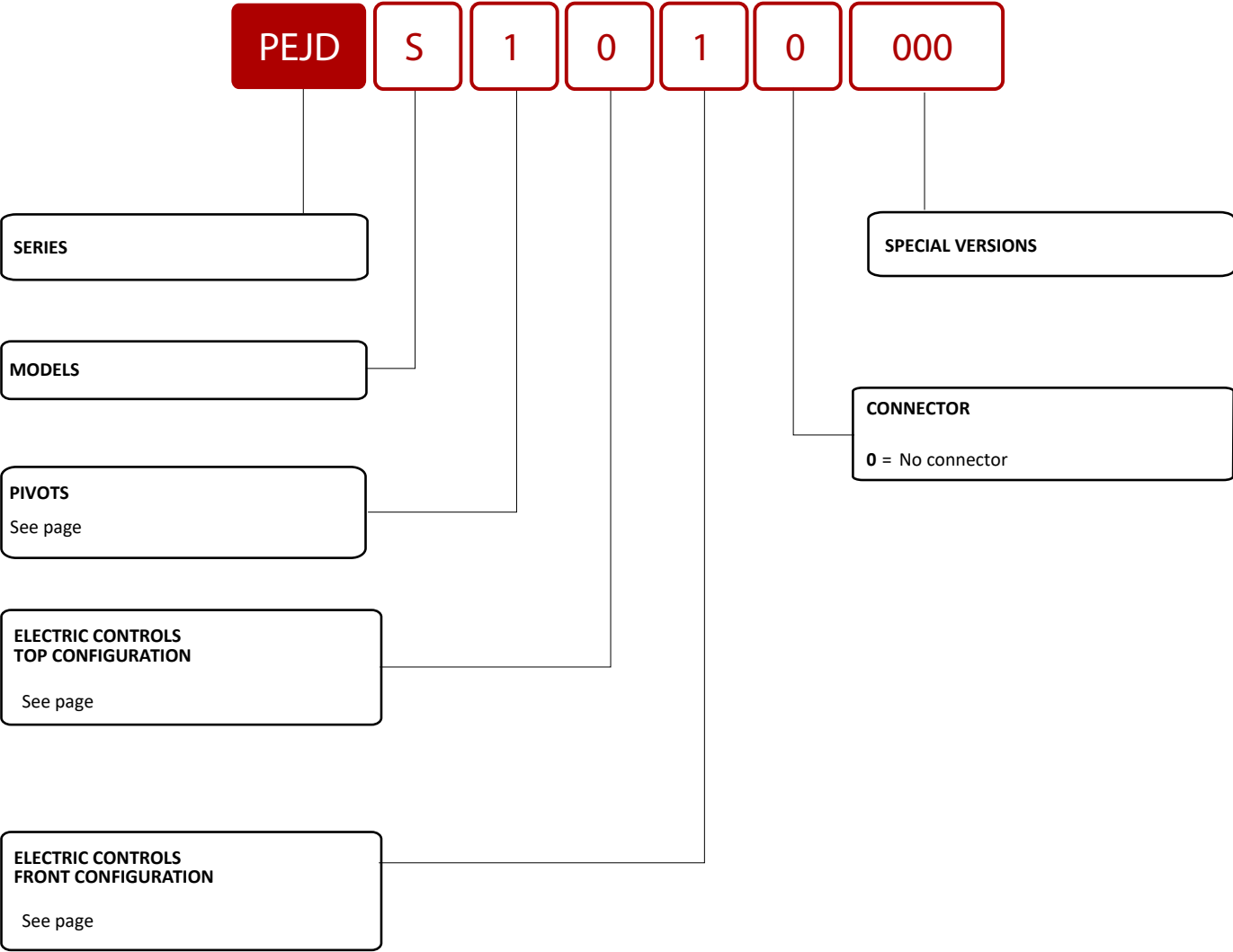

**K**

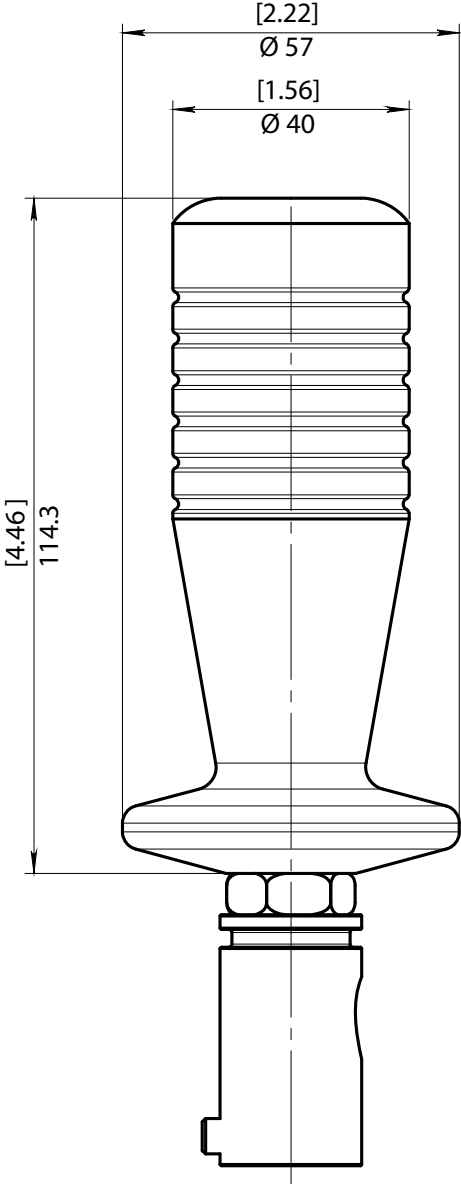

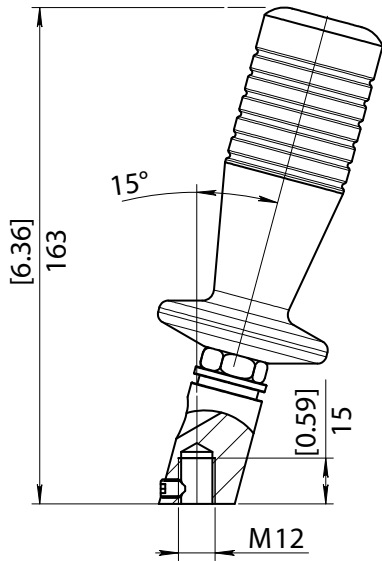

**1**

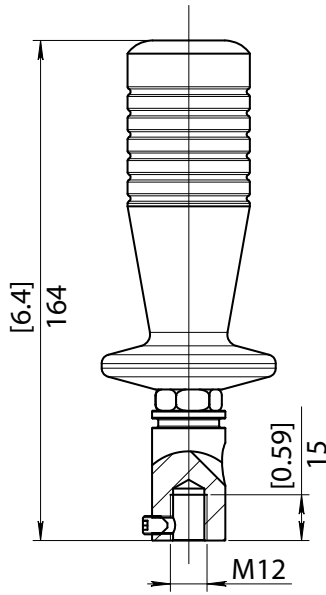

**2**

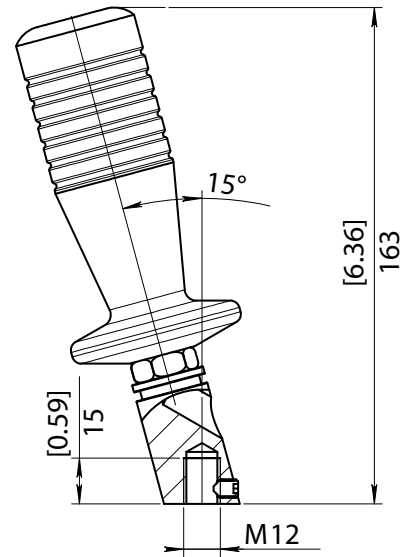

**3**

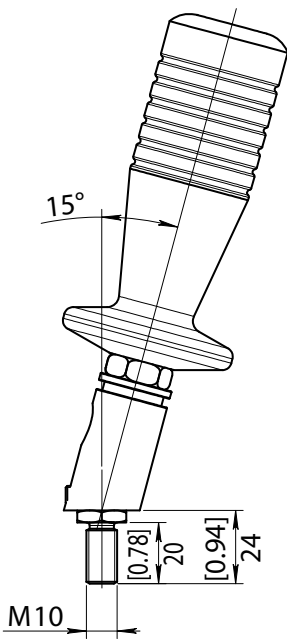

**4**

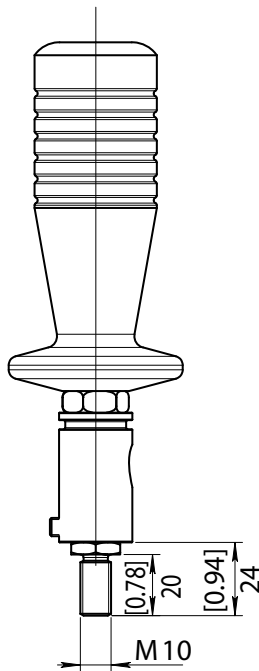

**5**

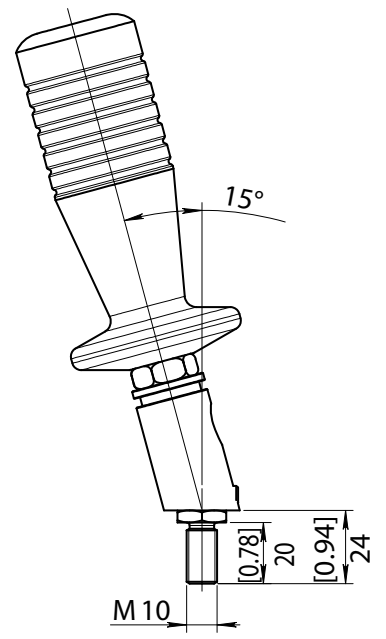

**6**

**1** RIGHT TILTED 15° M12

**4** RIGHT TILTED 15° M10

**2** STRAIGHT M12

**5** STRAIGHT M10

**3** LEFT TILTED 15° M12

**6** LEFT TILTED 15° M10



TOP CONFIGURATIONS

T1

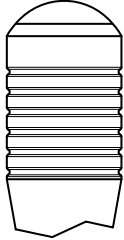

SINGLE BUTTON WITH SPRING RETURN

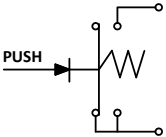

T2

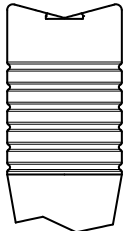

TOGGLE BUTTON

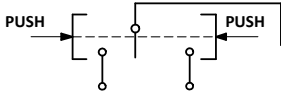

MICRO CAPACITY: DC 12V x 8A

T3

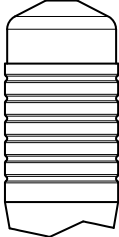

SINGLE PUSH-PUSH BUTTON

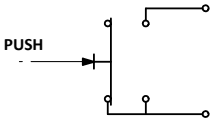

MICRO CAPACITY:  
DC 28V x 10A RESISTIVE;  
DC 28V x 5A INDUCTIVE

FRONT CONFIGURATIONS

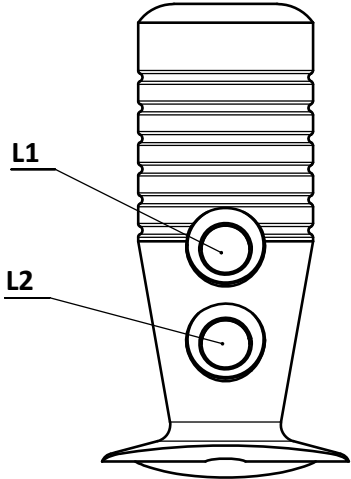

SINGLE MOMENTARY BUTTON

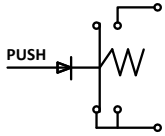

MICRO CAPACITY: DC 28V x 5A RESISTIVE;  
DC 28V x 3A INDUCTIVE

**O** NO TOP BUTTON

**B** T1 SINGLE TOP BUTTON

**C** T2 TOGGLE TOP BUTTON

**D** T3 PUSH-PUSH TOP BUTTON

**O** NO SIDE BUTTON

**F** L1 MOMENTARY BUTTON

**G** L2 MOMENTARY BUTTON

**H** L1 + L2

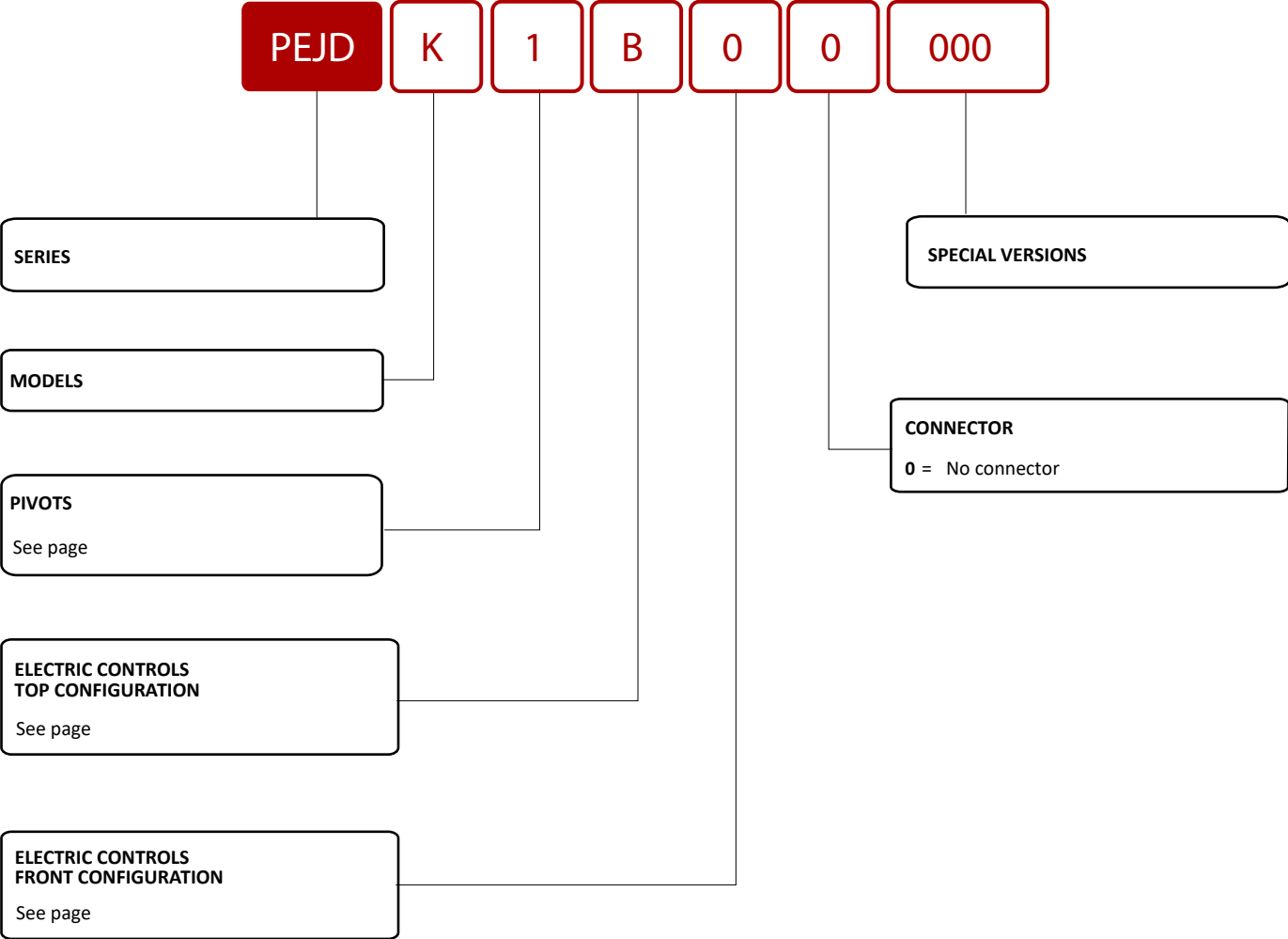

**E**

ERGONOMIC HANDLE

**F**

VERSION "E" + NO OPERATOR SAFETY

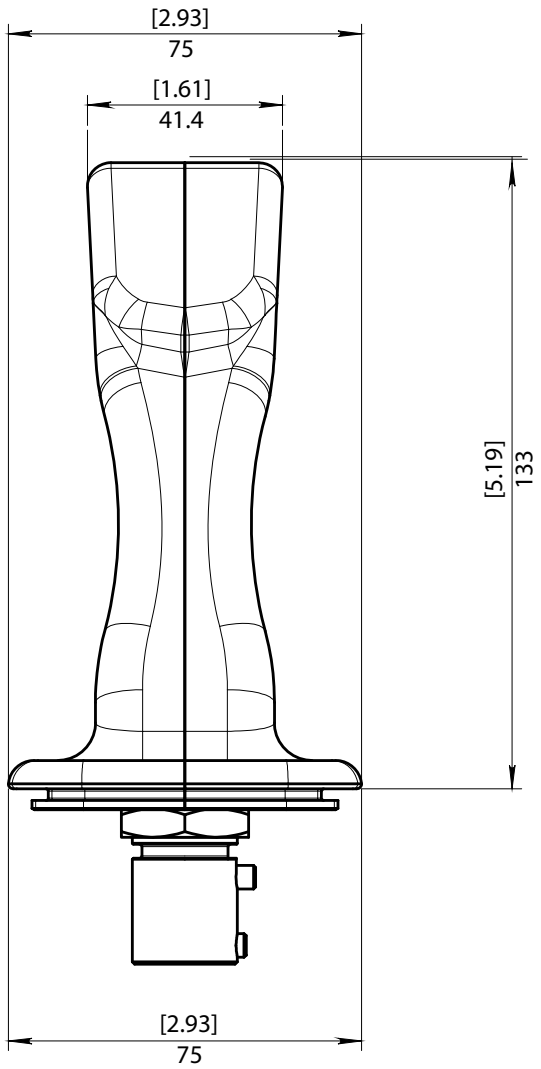
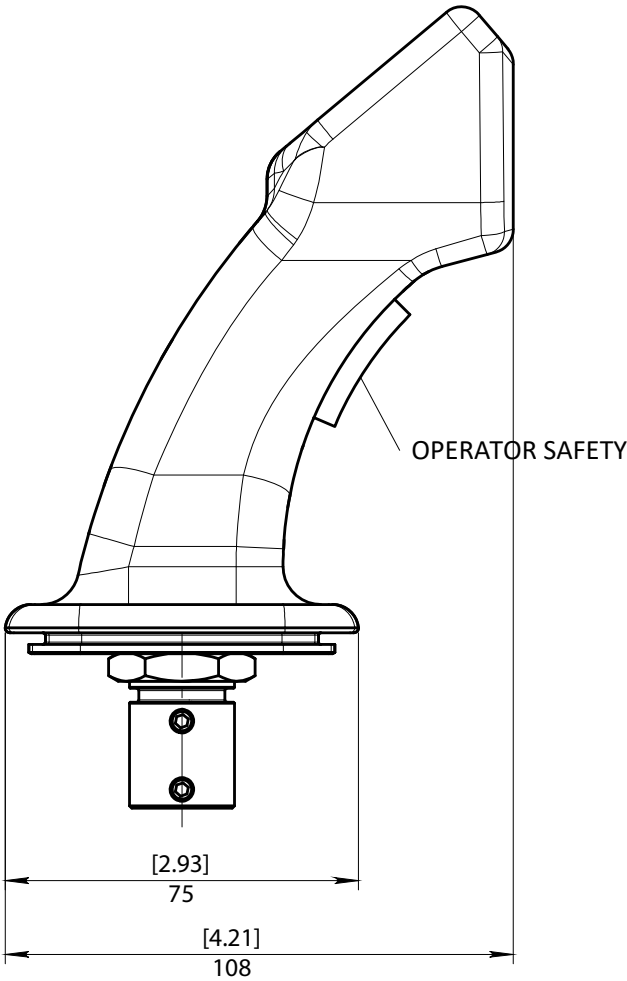

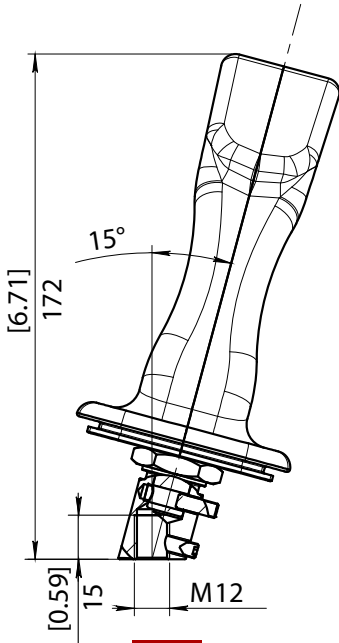

**1**

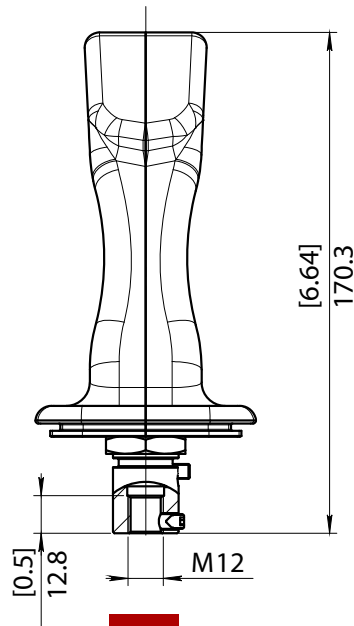

**2**

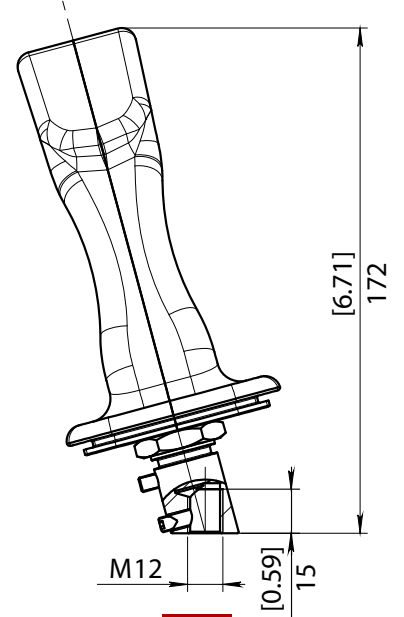

**3**

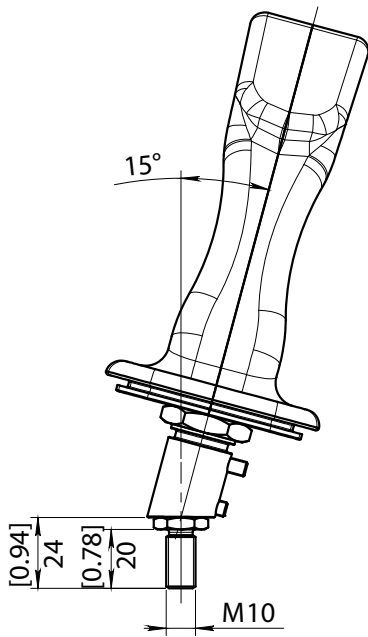

**4**

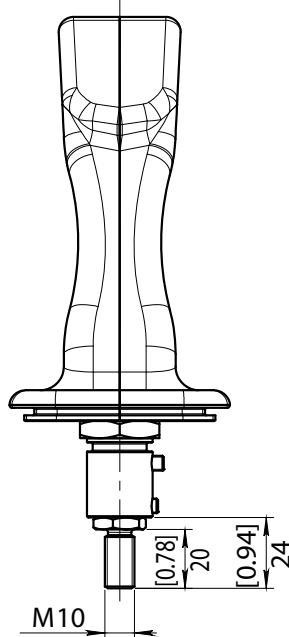

**5**

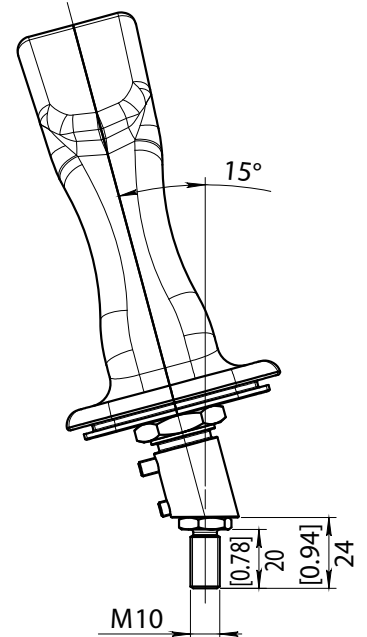

**6**

**1** RIGHT TILTED 15° M12

**4** RIGHT TILTED 15° M10

**2** STRAIGHT M12

**5** STRAIGHT M10

**3** LEFT TILTED 15° M12

**6** LEFT TILTED 15° M10

TOP CONFIGURATIONS

FRONT CONFIGURATIONS

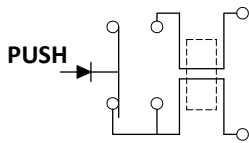
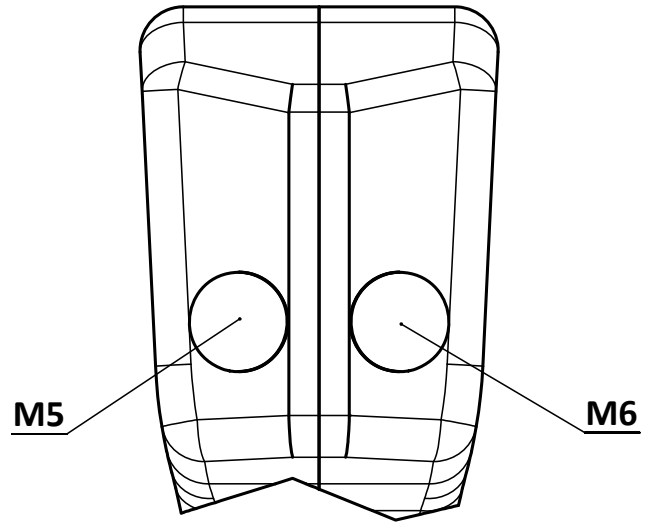
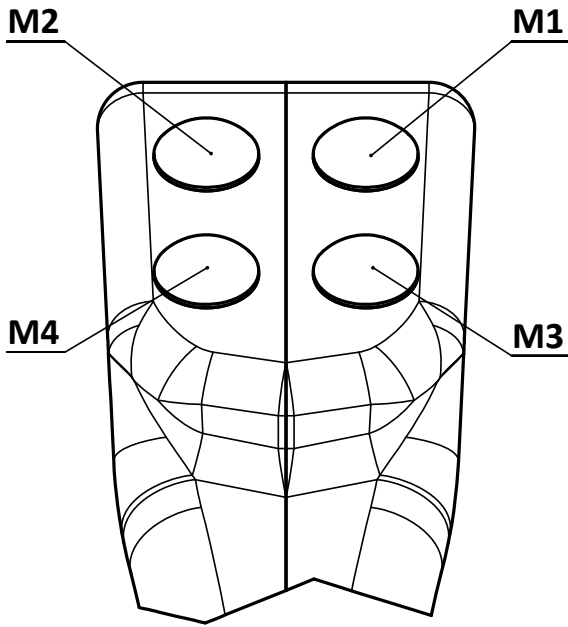

MICRO CAPACITY: DC 12V x 2A

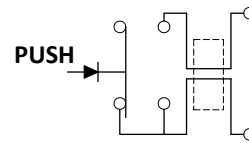

MICRO CAPACITY: DC 12V x 2A

BUTTONS ONLY AVAILABLE IN GREEN

BUTTONS ONLY AVAILABLE IN GREEN

- 0** NO TOP BUTTON
- 1** M1
- 2** M1+M2
- 3** M1+M2+M3
- 4** M1+M2+M3+M4
- 5** M2

- 0** NO TOP BUTTON
- 1** M5
- 2** M5+M6
- 3** M6

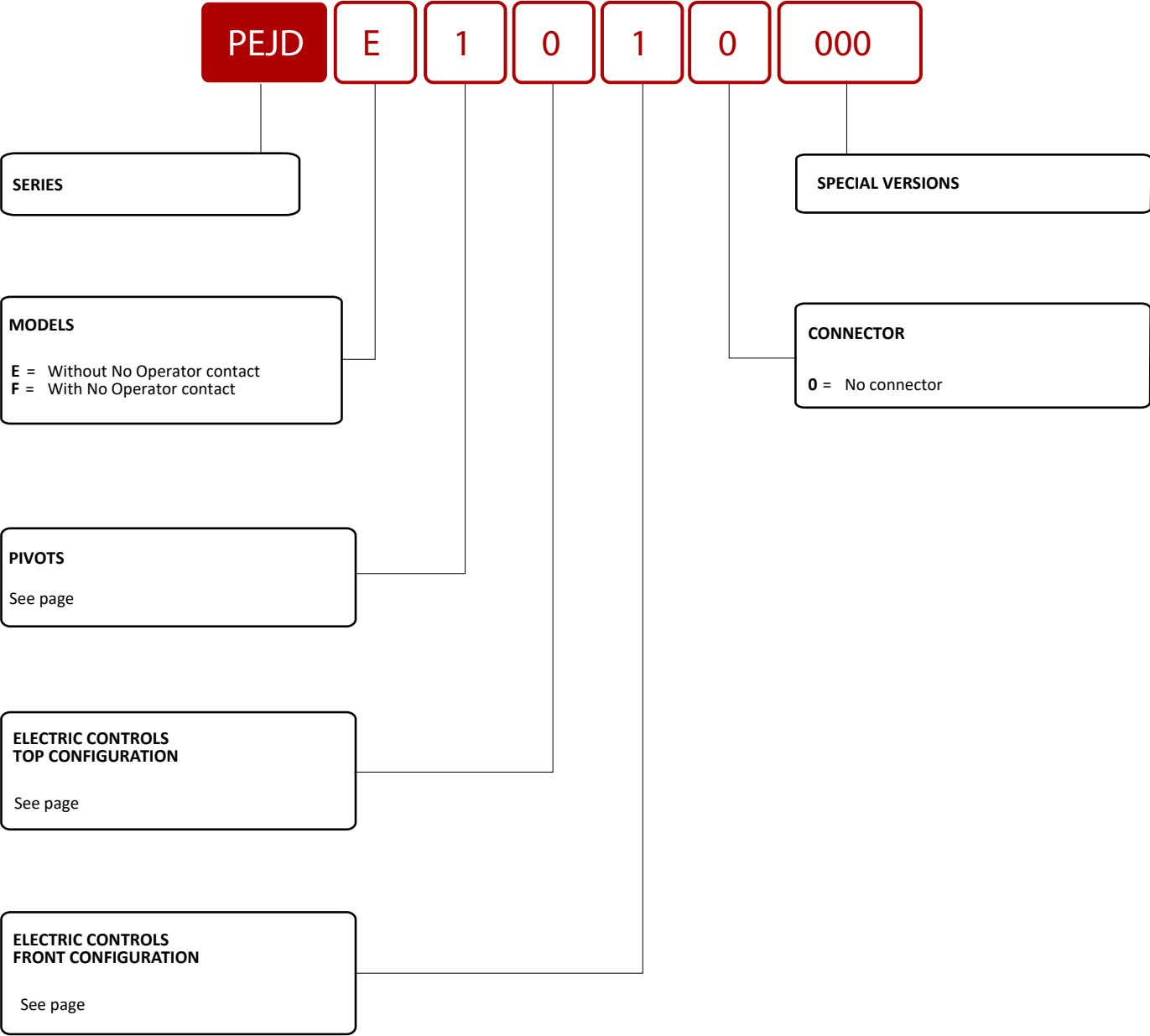

**T**

MULTIFUNCTION HANDLE

**H**

VERSION "T" WITH NO OPERATOR CONTACT

**V**

MULTIFUNCTION GRIP WITH PROPORTIONAL PWM SIGNAL

**Z**

VERSION "V" NO OPERATOR CONTACT

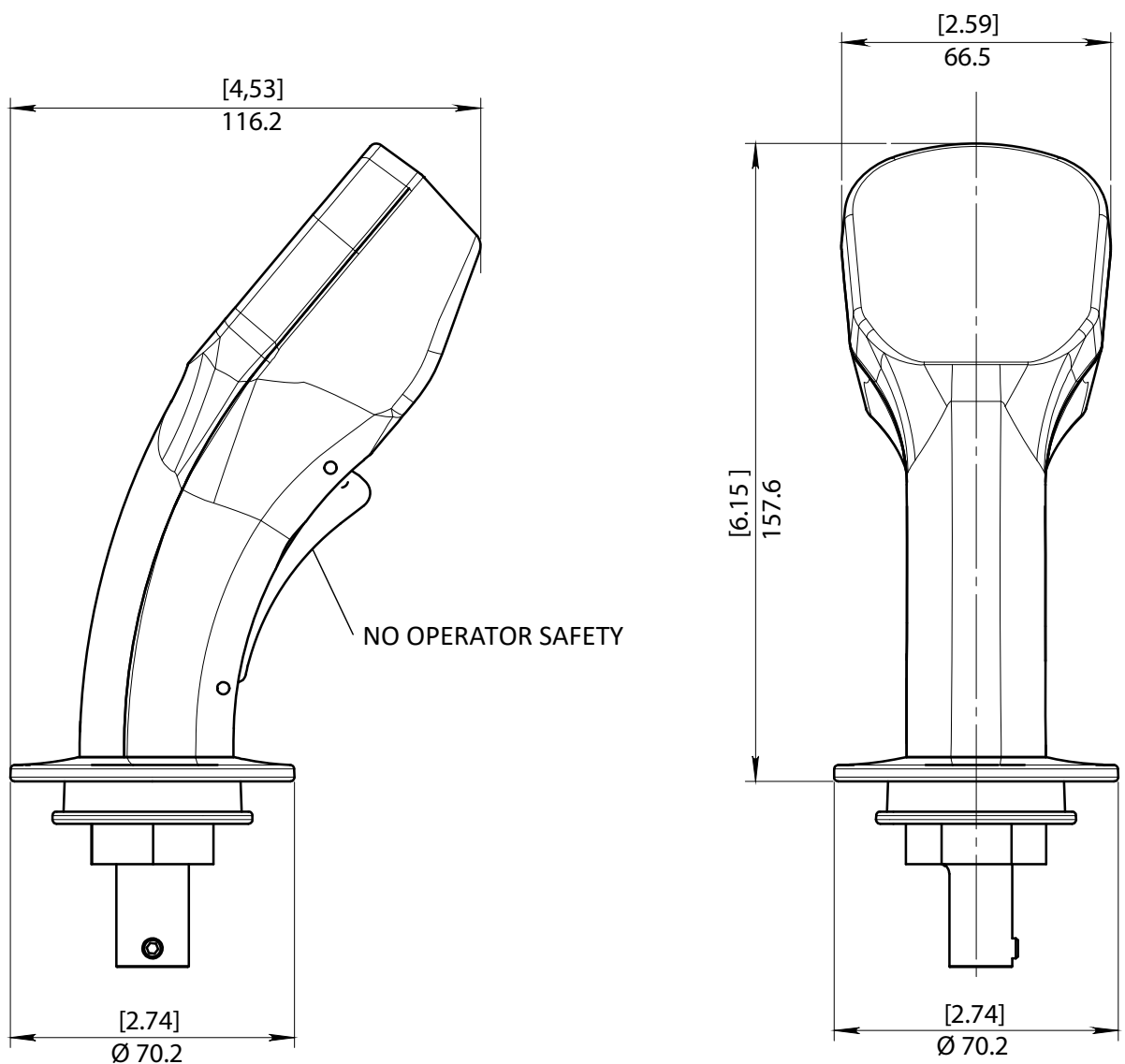

**PEJD Proportional electronic joystick double  
Multifunction grip**

Handles are available with electric controls, with electronic proportional controls (two controls maximum), or with both. The power signal (PWM) is generated by a control unit integrated into the handle. Nonetheless if the system already features an external electronic unit, the roller switch will deliver exclusively the potential difference, which is then processed in power signal.

In case of a handle with two electro-proportional controls, fitted on a two-axle servocontrol, the control on 4-axle is achieved.

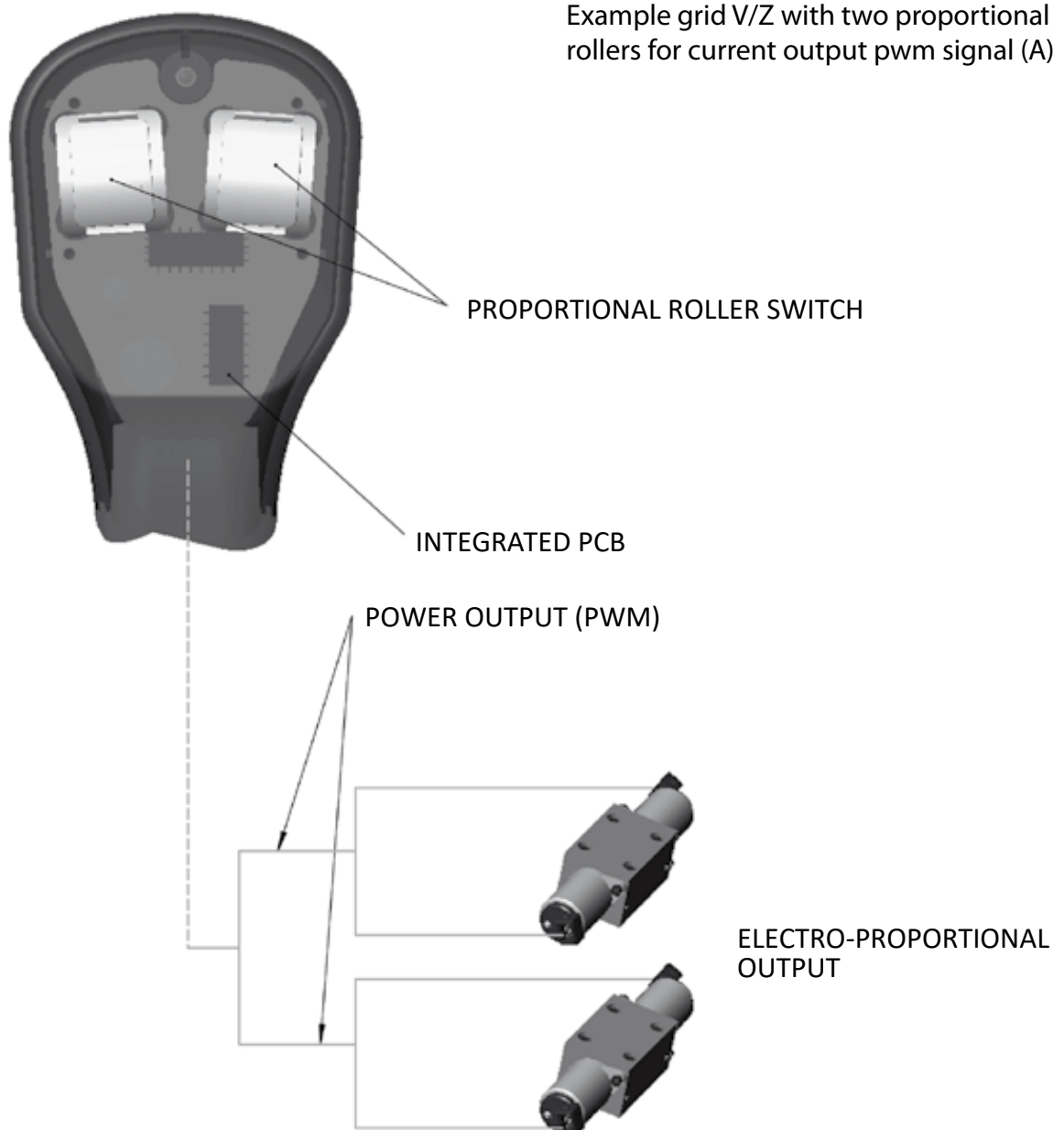



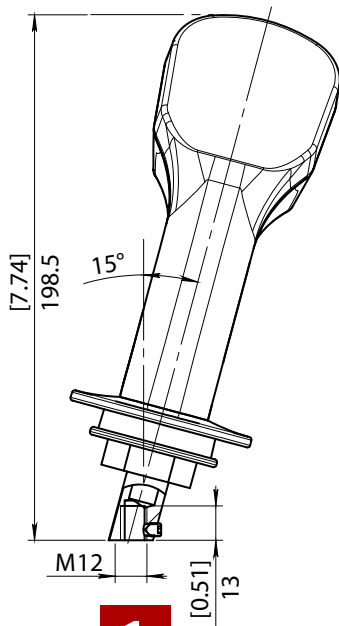

**1**

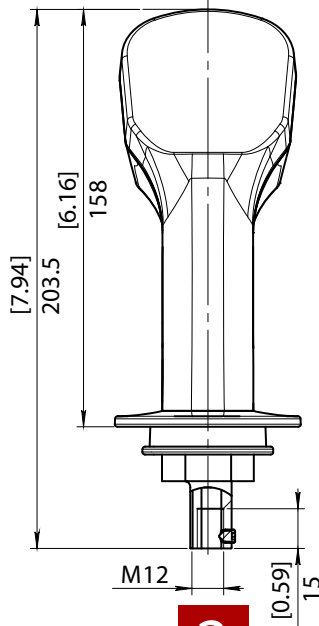

**2**

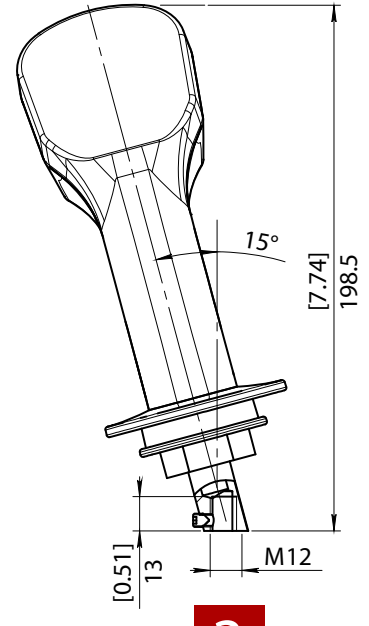

**3**

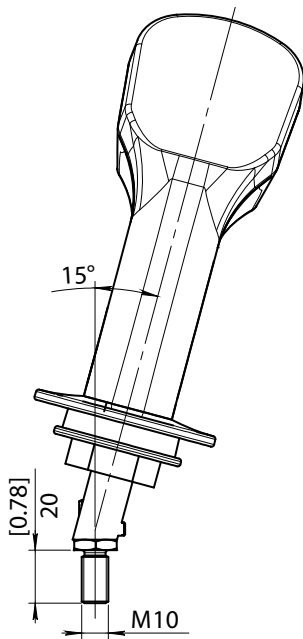

**4**

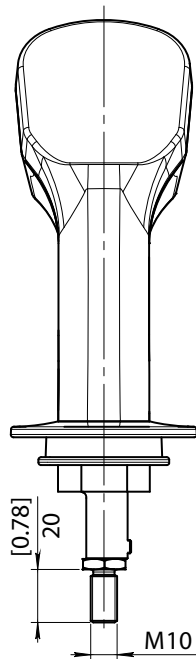

**5**

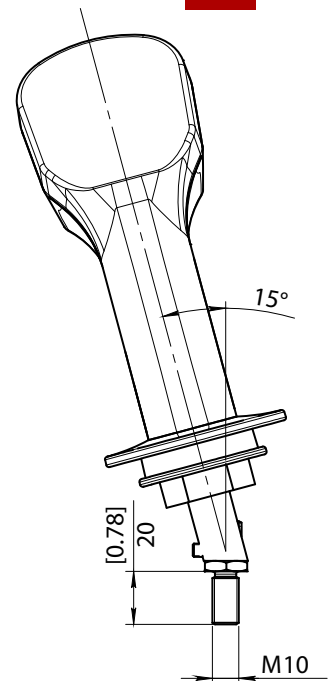

**6**

**1** RIGHT TILTED 15° M12

**2** STRAIGHT M12

**3** LEFT TILTED 15° M12

**4** RIGHT TILTED 15° M10

**5** STRAIGHT M10

**6** LEFT TILTED 15° M10

**T**  
**H**  
**V**  
**Z**

TOP CONFIGURATIONS

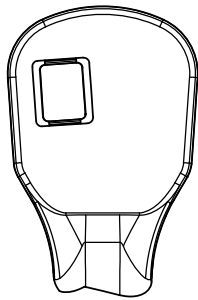

**RA**

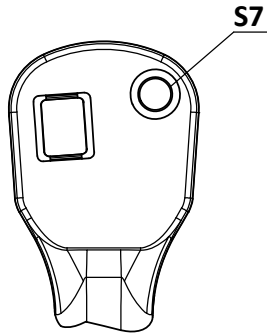

**RB**

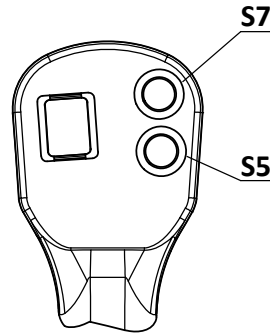

**RC**

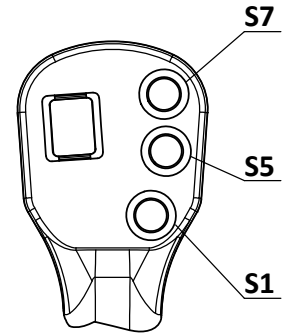

**RD**

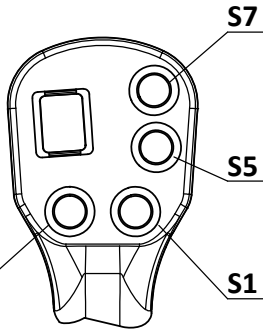

**RE**

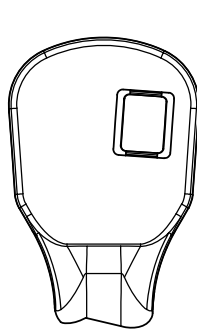

**RF**

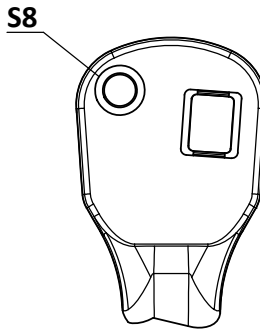

**RG**

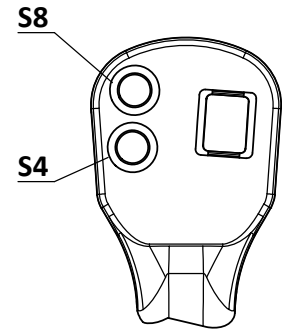

**RH**

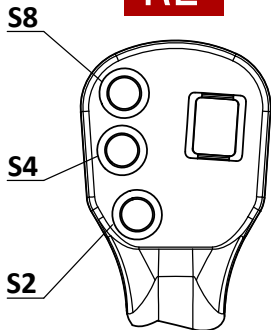

**RJ**

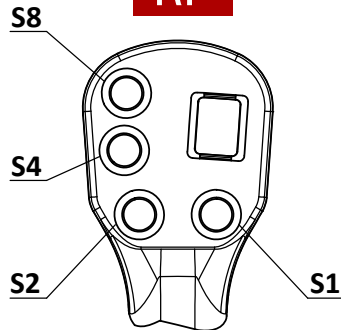

**RK**

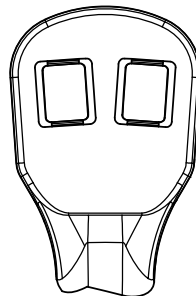

**RL**

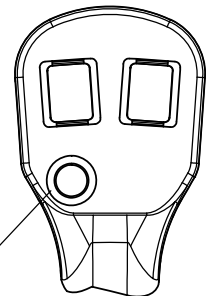

**RM**

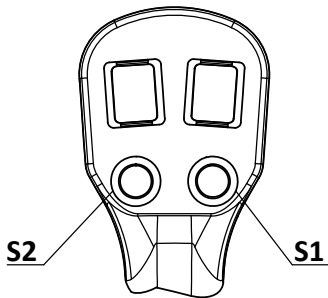

**RN**

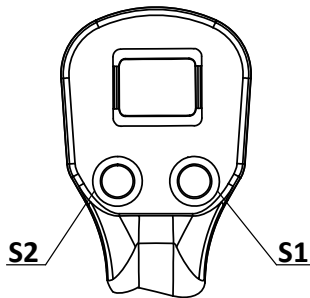

**RO**

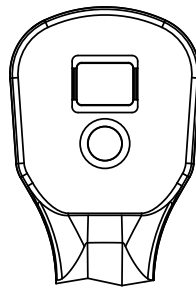

**RP**

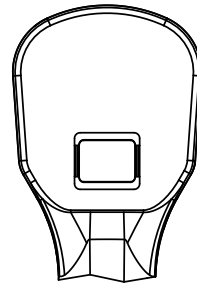

**RQ**

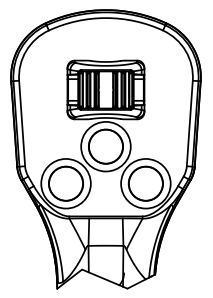

**RR**

TOP CONFIGURATIONS

**T**  
**H**

**V**  
**Z**

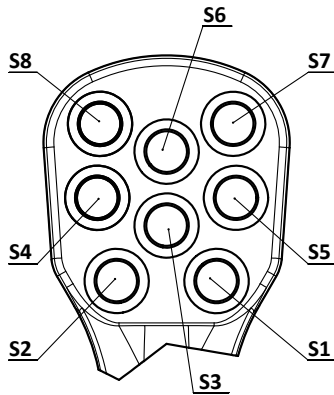
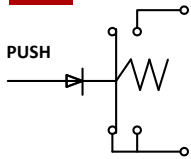

FRONT CONFIGURATIONS

**T**  
**H**

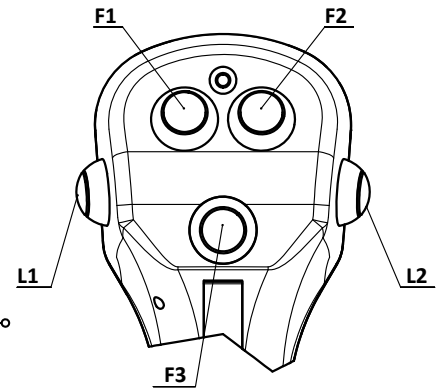
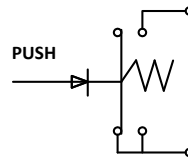

**00** NO TOP BUTTON

- 01** S1
- 02** S3
- 03** S1+S2
- 04** S4+S5
- 05** S1+S2+S5
- 06** S1+S2+S4+S5
- 07** S1+S2+S3+S4+S5
- 08** S1+S2+S3+S4+S5+S6
- 09** S1+S2+S3+S4+S5+S7+S8
- 0A** S1+S2+S3+S4+S5+S6+S7+S8
- 0B** S3+S7+S8
- 0C** S1+S2+S4+S5+S7+S8
- 0D** S4+S8
- 0E** S5
- 0F** S4
- 0G** S5+S7
- 0H** S3+S4+S5+S6
- 0I** S4+S5+S6
- 0J** S1+S2+S3

- OK** S4+S5+S7+S8
- OL** S6
- OM** S1+S2+S4+S5+S6
- ON** S3+S7
- OP** S1+S5+S7
- OQ** S1+S2+S7+S8
- OR** S2+S4
- OS** S3+S4+S5+S7+S8
- OT** S1+S7
- OU** S3+S6
- OV** S8
- OW** S2+S8
- OZ** S1+S2+S6

MICRO CAPACITY : DC 28V x 5A RESISTIVE  
DC 28V x 3A INDUCTIVE

The versions "V" and "Z" are not prepared for front switches.

- 0** NO TOP BUTTON
- 1** L1
- 2** L2
- 3** L1+L2
- 4** F1
- 5** F2
- 6** F3
- 7** F1+F2
- 8** F1+F2+F3
- 9** F1+F2+F3+L1+L2
- A** F1+F2+L1+L2
- B** F3+L1+L2
- C** F1+L1
- D** F1+F3
- E** F1+F3+L1+L2

The integrated PCB in the H/T hand grip is programmed specifically for each application as the ramp is designed to respond optimally to each operating condition.  
 You will therefore have to ask OMFB Hydraulic Components S.p.A. to assign you a 3-figure code once the application and correct ramp have been agreed (current delivered, % I<sub>max</sub>, depending on the position of the roller switch, degree).  
 Below are some examples of ramps available in standard configurations for the voltage, current and PWM frequency of the PCB.

**V**  
**Z**

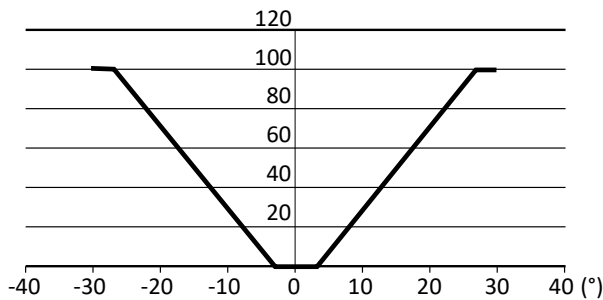

**5 | 0 | 0**

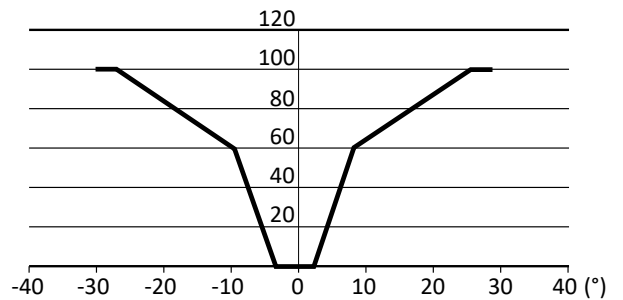

**5 | 0 | 1**

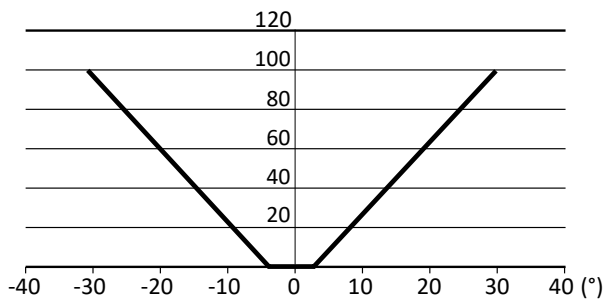

**5 | 0 | 2**

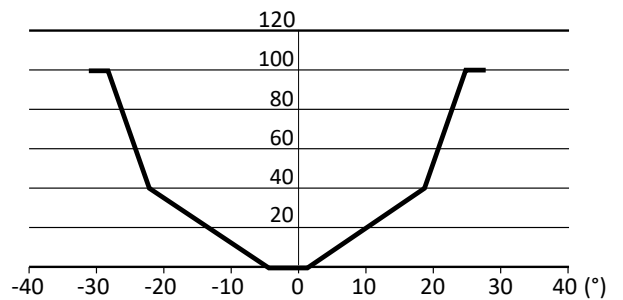

**5 | 0 | 3**

**0 | 0 | 0**

NO PWM SIGNAL

**V****Z****INPUT VOLTAGE****POWER OUTPUT (PWM)****STANDARD  
CONFIGURATIONS****POWER SUPPLY VOLTAGE**

Nominal 12 Vdc battery:  
9-16 Vdc effective  
Nominal 24 Vdc battery:  
18-30 Vdc effective

Maximum current - 1 channel  
3 A (@ 12 Vdc)  
2 A (@ 24 Vdc)  
Maximum current - total  
6.5 A (@ 12 Vdc)  
4.5 A (@ 24 Vdc)  
PWM frequency  
100 - 400 Hz

Standard programming configurations share the following parameters:

Supply voltage: 12V DC

Maximum current (per single channel) I<sub>max</sub> 1.5A

PWM frequency: 200Hz

Soft current ramps both when increasing and decreasing, and different output curves (current supplied in accordance with the position of the roller switch).

**PROTECTION RATING**

In configurations with buttons and roller switches, the hand grip is IP67 protected.

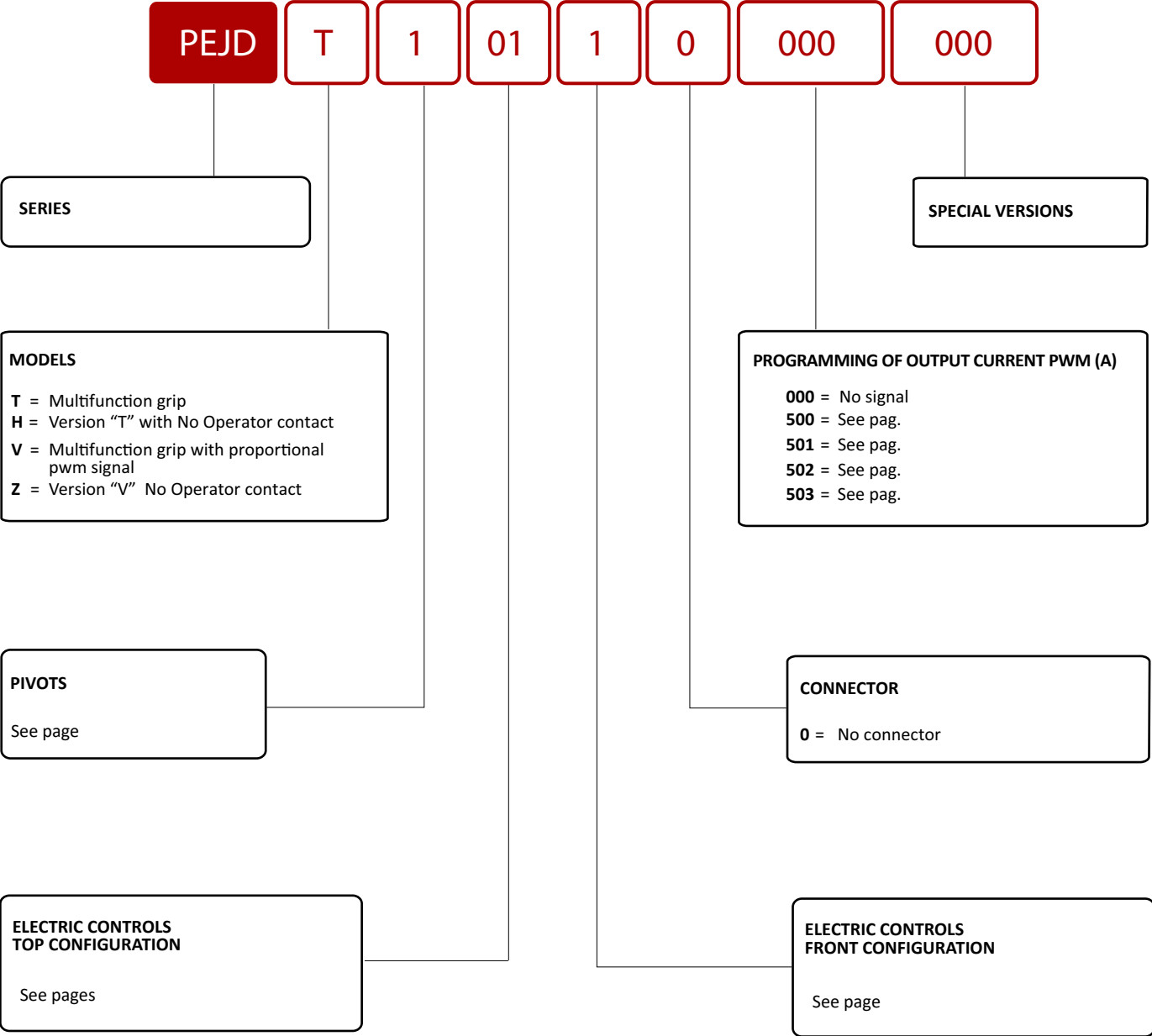

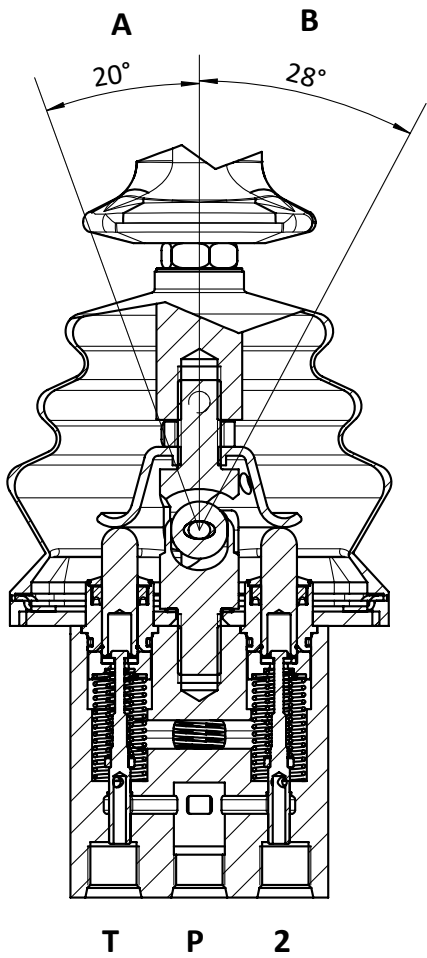

<b>A</b>	Angle of the lever with just one actuator operated
<b>B</b>	Angle of the lever with two actuators operated simultaneously

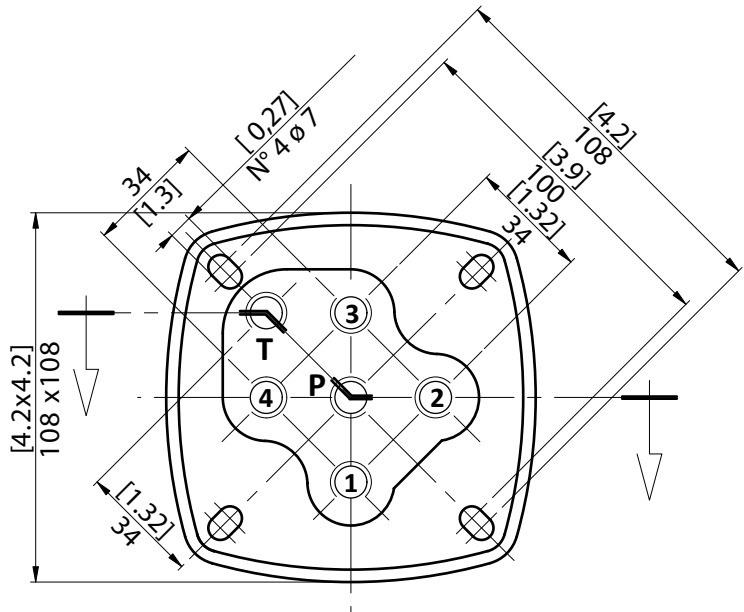

Actuator directions

Hydraulic diagram

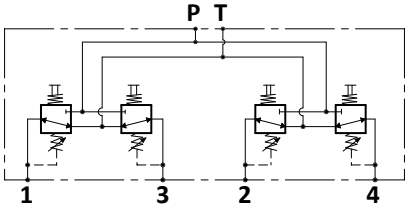
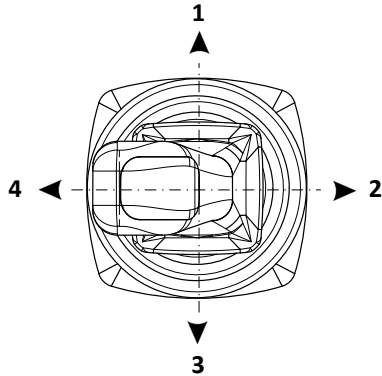

<b>1, 2, 3, 4</b>	Uses
<b>T</b>	Tank
<b>P</b>	Inlet

**1** A pressure signal from axis 2-4

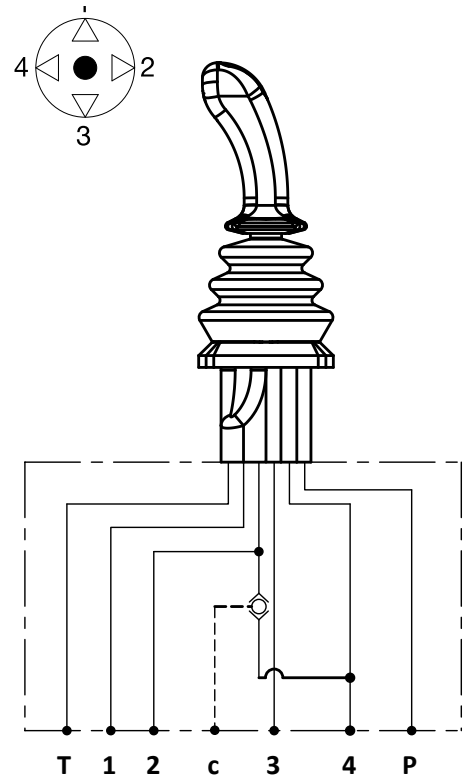
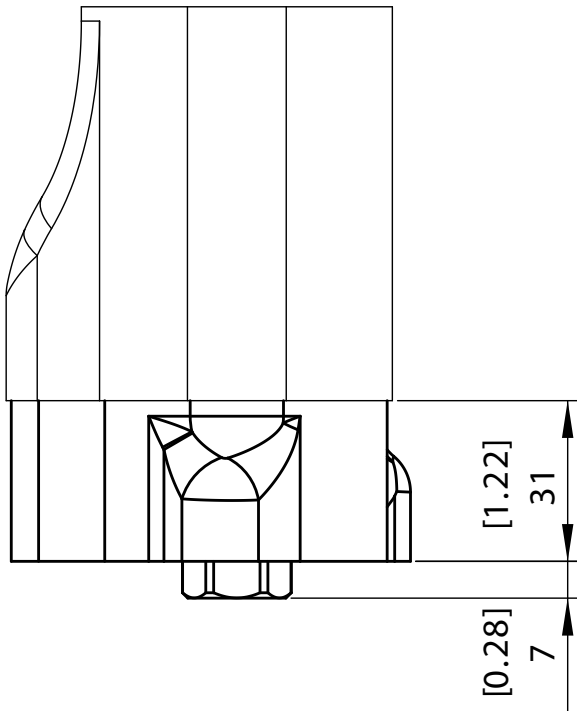

**2** Two pressure signals from axis 1-3 and 2-4

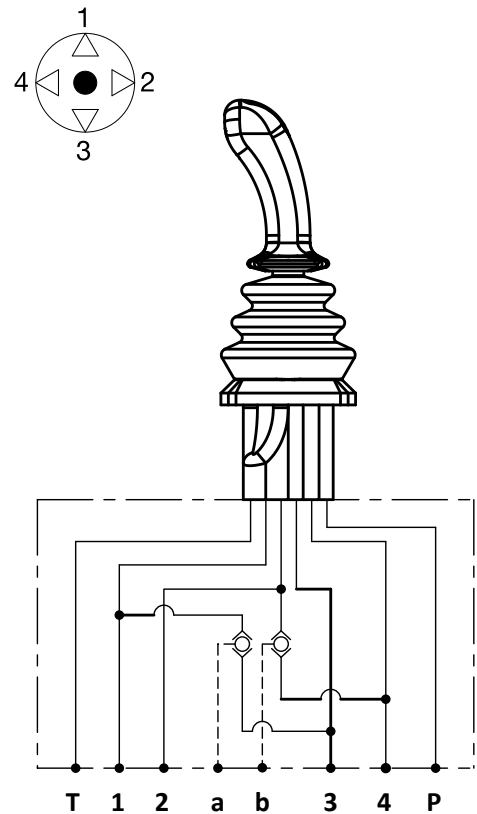
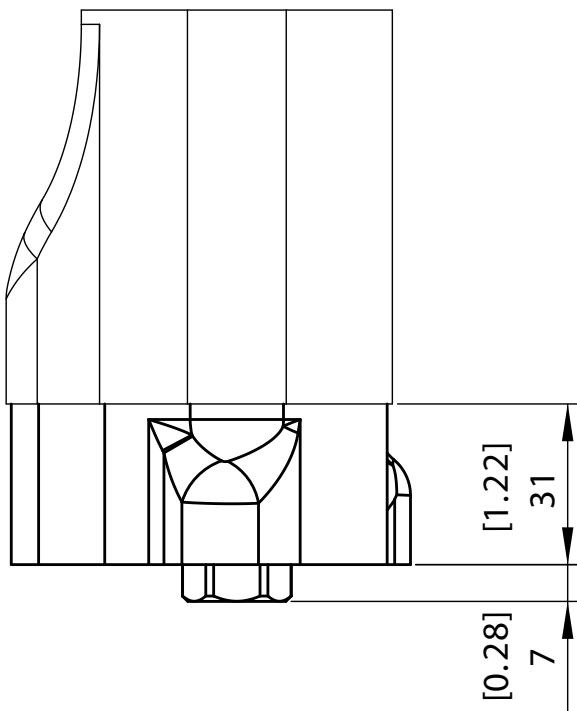



### 3 Opposite counter rotation

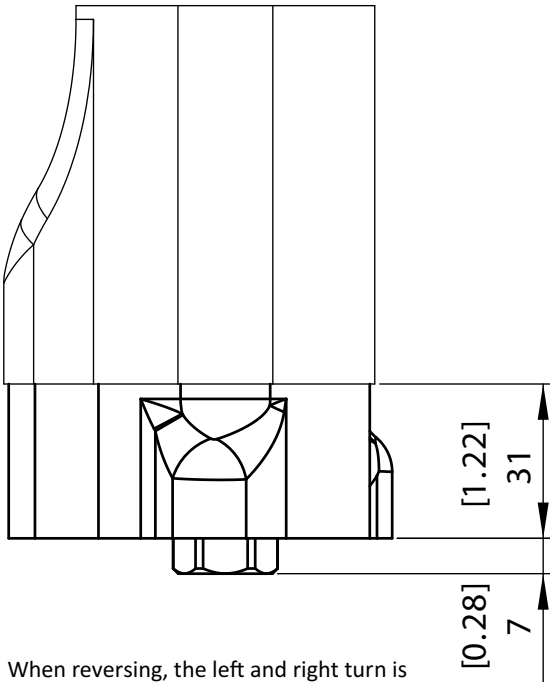

When reversing, the left and right turn is opposite to the inclination of the lever.

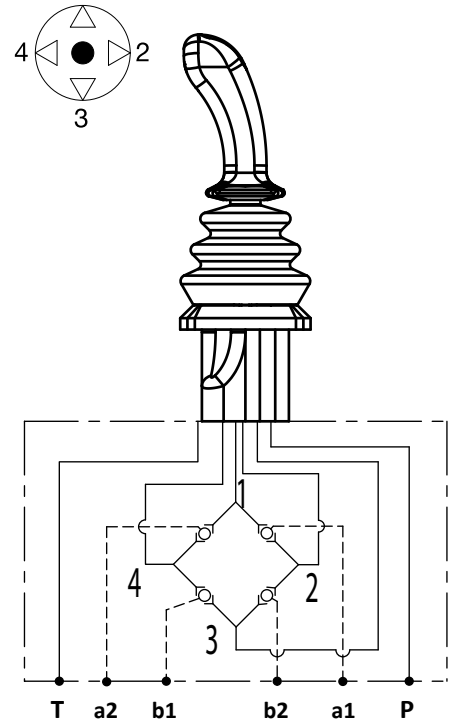

### 4 One pressure signal from each position

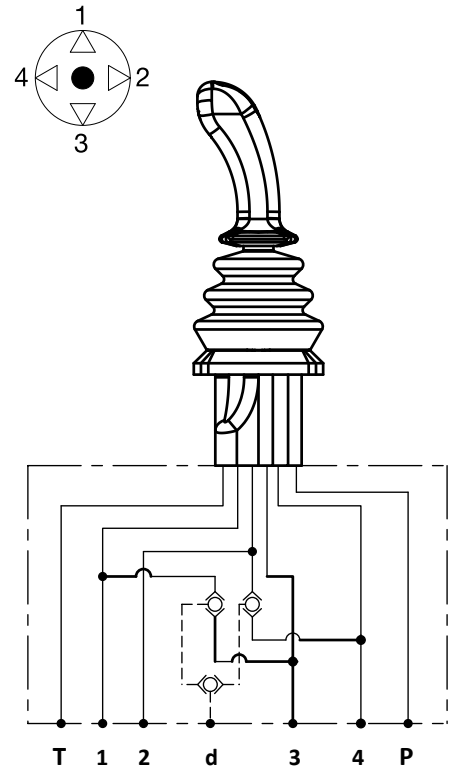
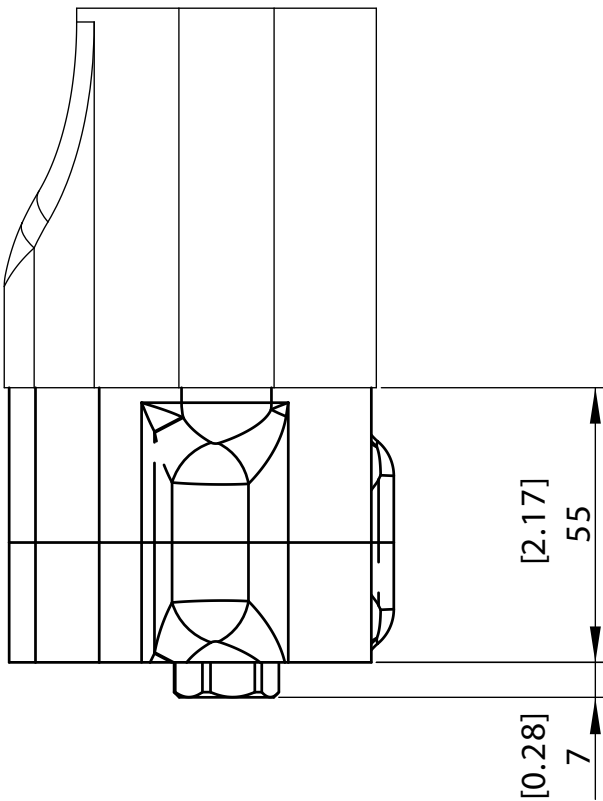

**5** Opposite counter rotation with reverse signal

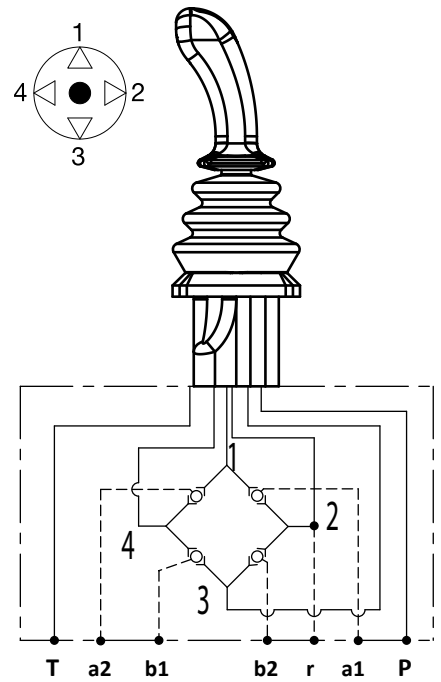
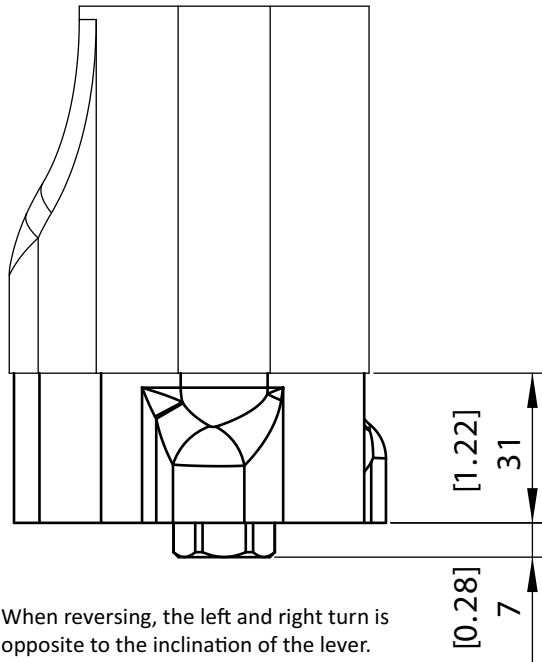

**6** Concordant counter rotation

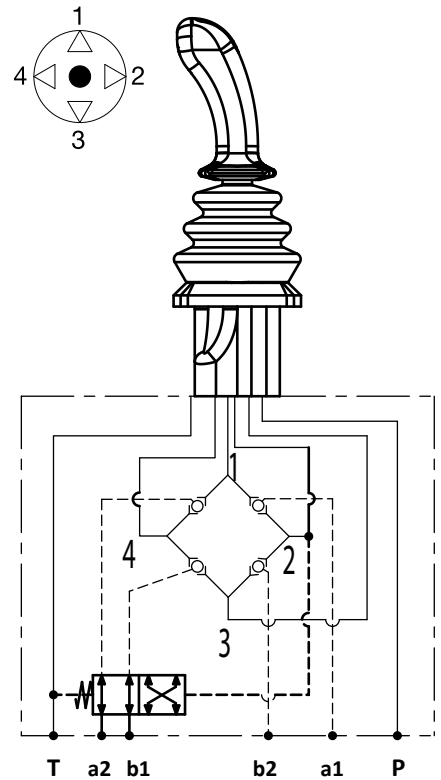
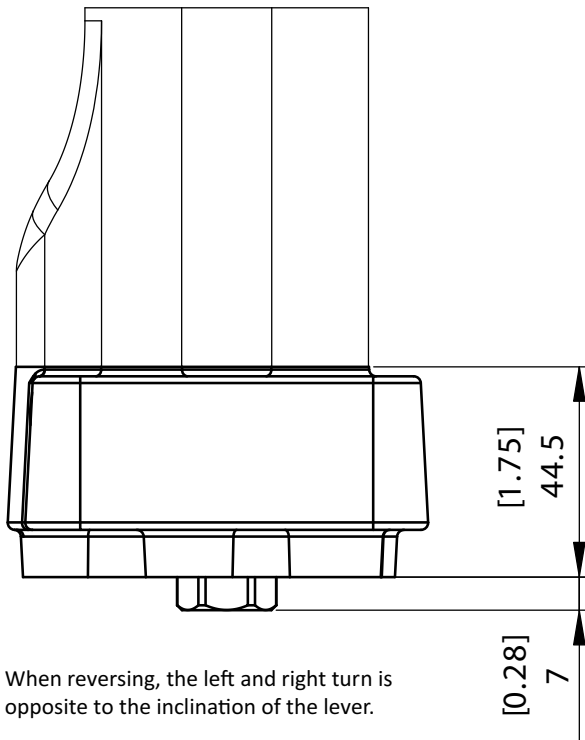

**7** Concordant counter rotation and reverse signal

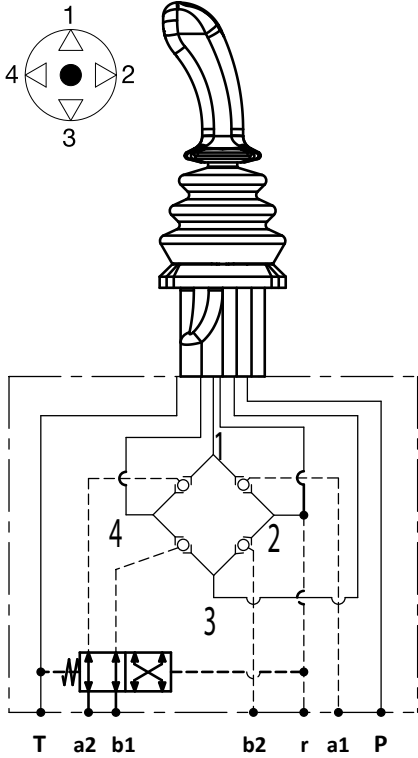
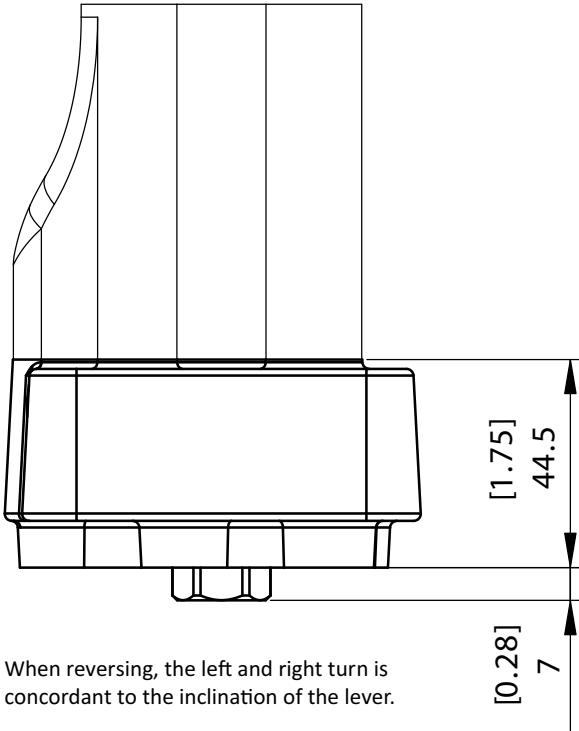

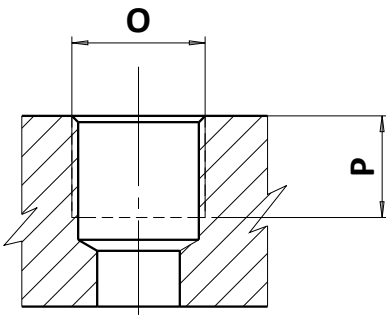

Type G2- U3

Type	O		P	
		Nm	mm	in
<b>G2</b>	1/4"	17	12	0.47
<b>U3</b>	9/16-18 UNF	25	13	0.47

**S Anatomical**

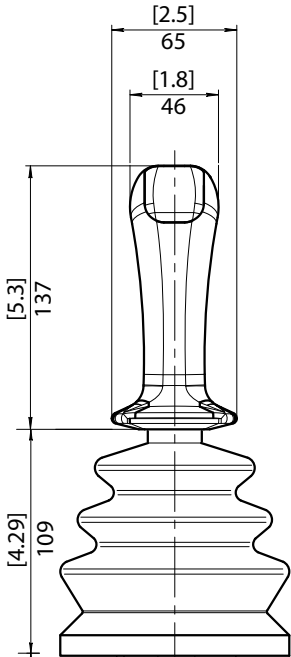

**K Cylindrical**

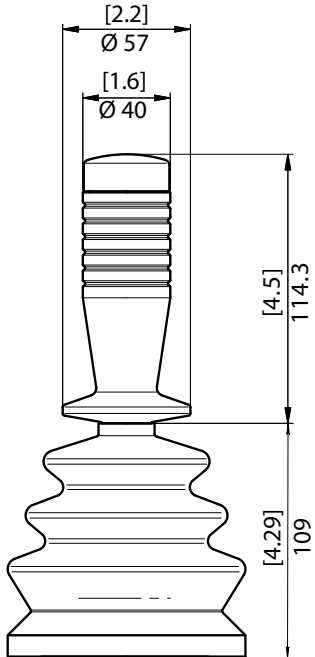

**E Ergonomic**

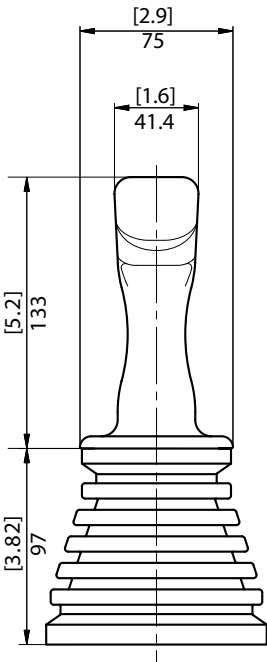

**F Ergonomic present person**

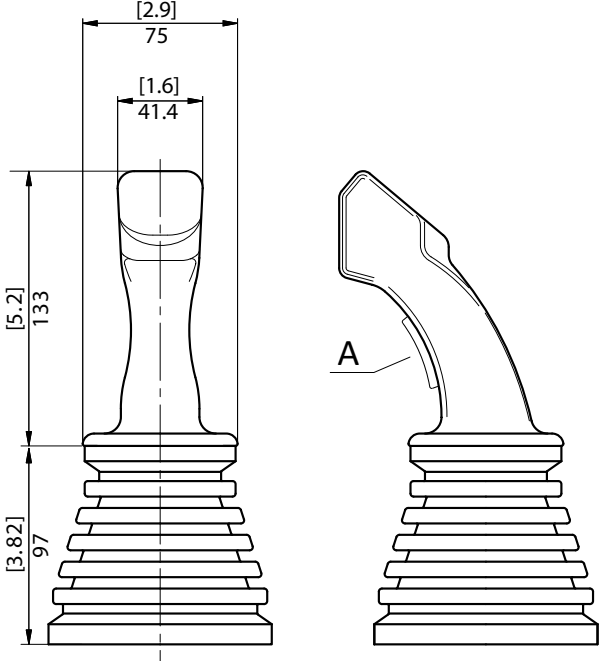

**A Present person button**

**T Multifunctional**

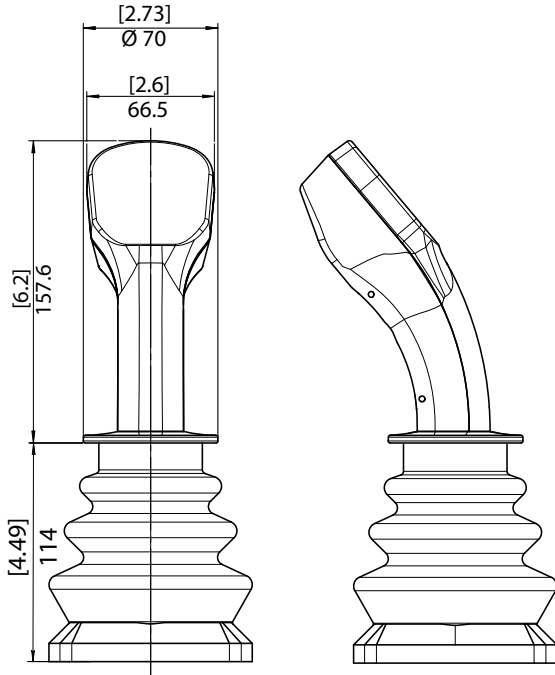

**H Multifunctional present person**

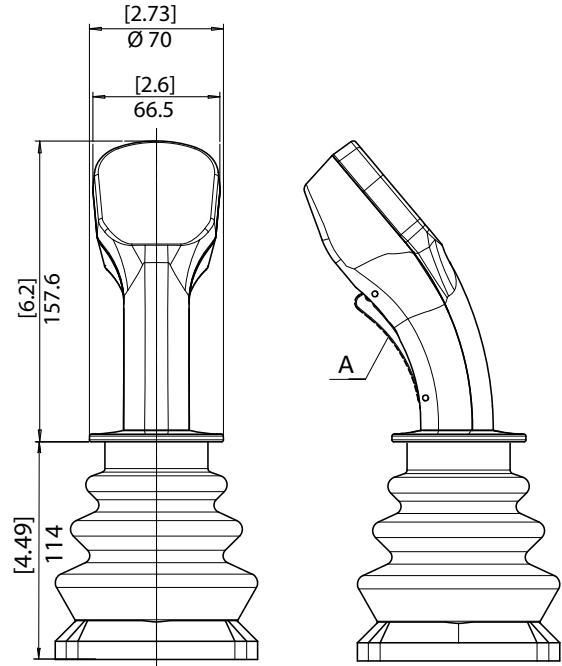

**A Present person button**

**V Multifunctional PWM**

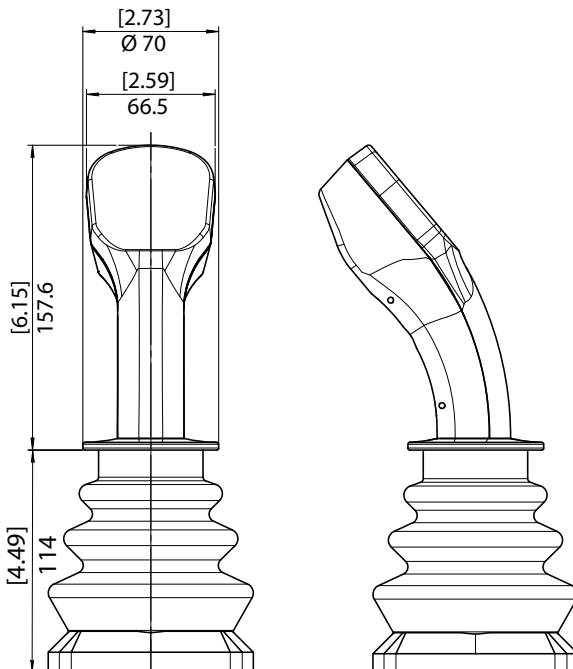

Power supply voltage 12 V	<b>9-16 Vdc effective</b>
Power supply voltage 24 V	<b>18-30 Vdc effective</b>
Maximum output current 1 channel	<b>3 A (@ 12 Vdc) 2 A (@ 24 Vdc)</b>
Maximum output current Total	<b>6.5 A (@ 12 Vdc) 4.5 A (@ 24 Vdc)</b>
PWM frequency	<b>100 - 400 Hz</b>
Standard configuration	<b>12 Vdc I max=1.5 A PWM = 200 Hz</b>
Handle protection level	<b>IP67</b>

\* Soft current ramps, both increasing and decreasing and different output curves (current supplied according to the roller position)

**Z Multifunctional PWM Present person**

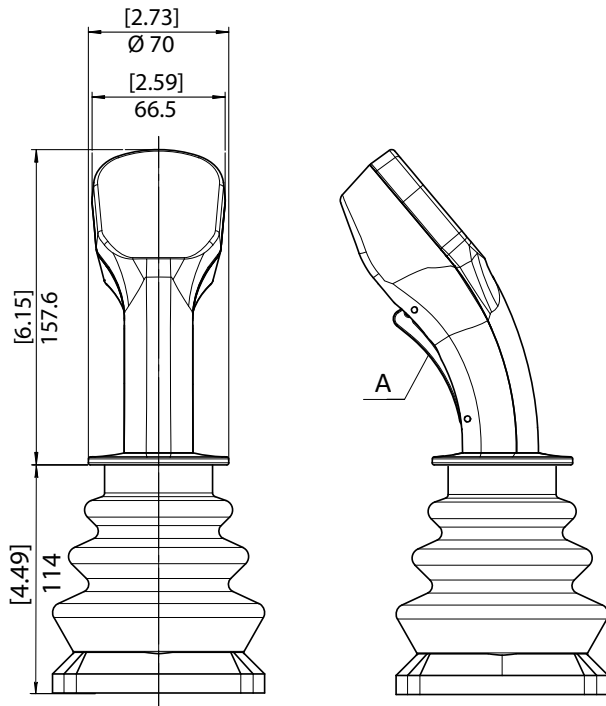

**A - Present person button**

Power supply voltage 12 V	<b>9-16 Vdc effective</b>
Power supply voltage 24 V	<b>18-30 Vdc effective</b>
Maximum output current 1 channel	<b>3 A (@ 12 Vdc) 2 A (@ 24 Vdc)</b>
Maximum output current Total	<b>6.5 A (@ 12 Vdc) 4.5 A (@ 24 Vdc)</b>
PWM frequency	<b>100 - 400 Hz</b>
Standard configuration	<b>12 Vdc I max=1.5 A PWM = 200 Hz</b>
Handle protection level	<b>IP67</b>

\* Soft current ramps, both increasing and decreasing and different output curves (current supplied according to the roller position)

**S** With spring return to centre

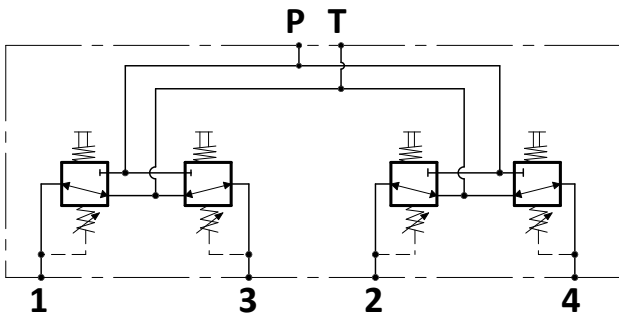

**A** Clutch controller forward/back 2-4

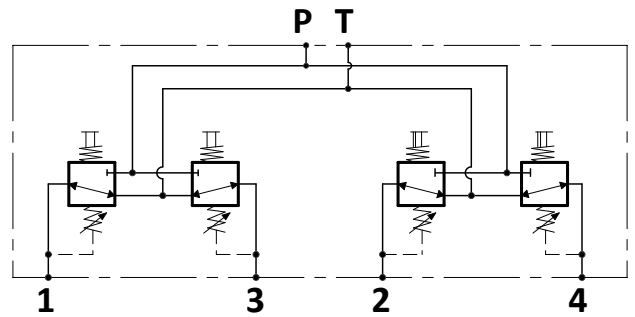

**M** Mechanical position 4

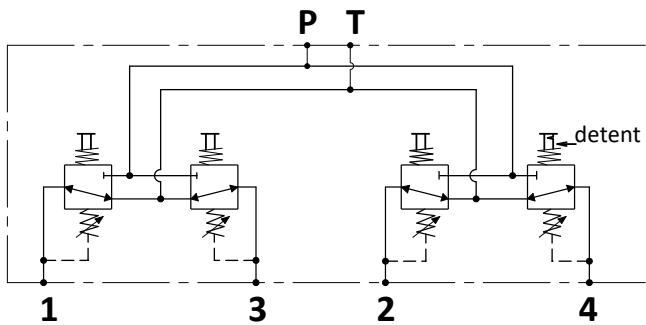

**E** Electromagnetic position 4 12 V

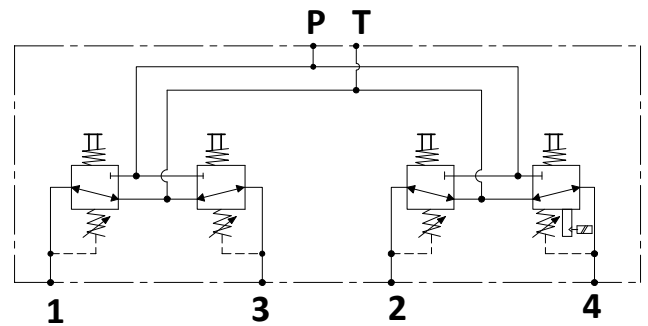

**F** Electromagnetic position 4 24 V

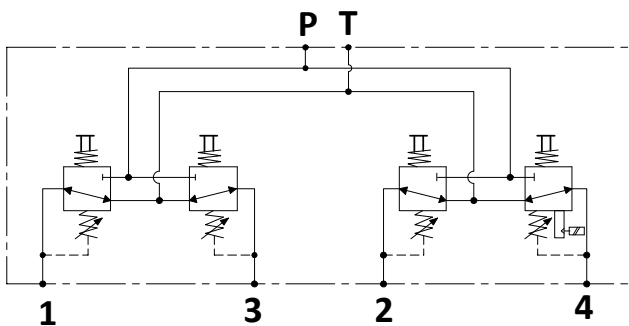



**S..** Single ramp with step

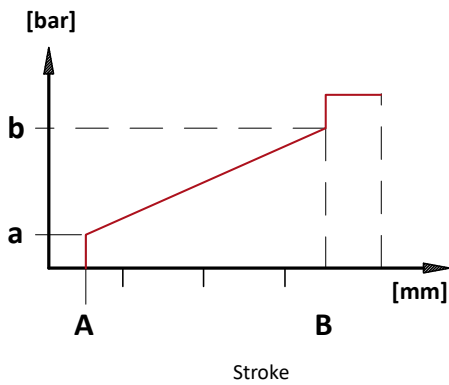

Type	Pressure a		Pressure b	
	bar	psi	bar	psi
<b>S00</b>	2	29	16	232
<b>S01</b>	5	73	20	290
<b>S02</b>	6.5	94	24.5	355
<b>S04</b>	3	46	17	249
<b>S08</b>	5	73	16	232
<b>S11</b>	4	58	15	218
<b>S12</b>	1.5	22	7	102
<b>S13</b>	5	73	28	406

**L..** Single ramp without step

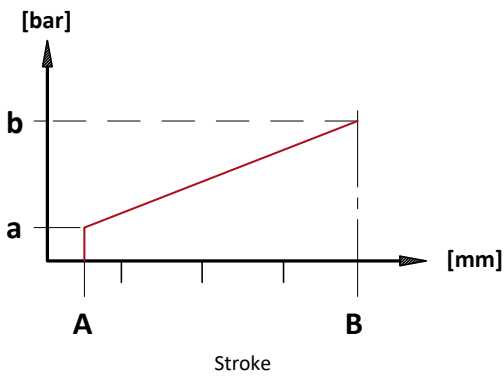

Type	Pressure a		Pressure b	
	bar	psi	bar	psi
<b>L00</b>	2	29	18	261
<b>L01</b>	5	73	22	319
<b>L02</b>	6.5	94	26.5	384
<b>L04</b>	3	46	19	276
<b>L08</b>	5	73	18	261
<b>L11</b>	4	58	16	218
<b>L12</b>	1.5	22	9	131
<b>L13</b>	5	73	30	435

**M60** Double ramp with step

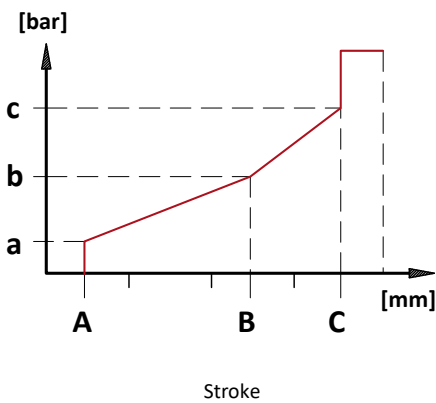

Type	Pressure a		Pressure b		Pressure c		Stroke		
	bar	psi	bar	psi	bar	psi	A mm	B mm	C mm
<b>M60</b>	5	73	12	174	21	306	1.2	5.4	7.8

**G60** Double ramp without step

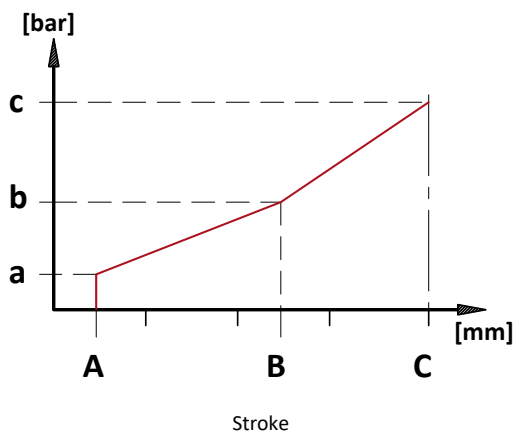

Type	Pressure a		Pressure b		Pressure c		Stroke		
	bar	psi	bar	psi	bar	psi	A mm	B mm	C mm
<b>G60</b>	5	73	12	174	23	334	1.2	5.4	8.3

Upper electric controls

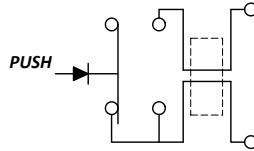
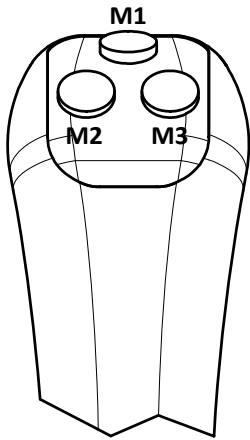

DC 12V x 2A

Configurations

Code	Description
<b>00</b>	No button
<b>01</b>	M1
<b>02</b>	M2+M3
<b>03</b>	M1+M2+M3

Front electric controls

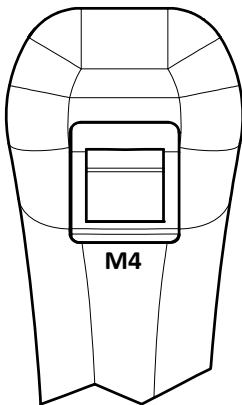

Rocker switch

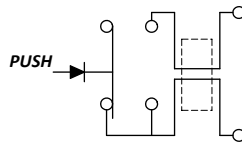

ON/OFF switch

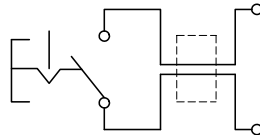

Configurations

Code	Description
<b>0</b>	No switch
<b>1</b>	M4 rocker with spring-back
<b>2</b>	M4 ON/OFF switch

**0B** Single top button with return

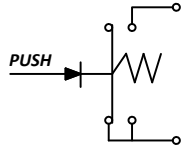
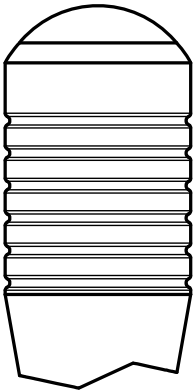

DC 12V x 8A

**0C** Rocker top button

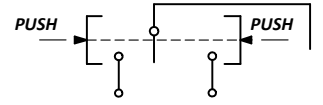
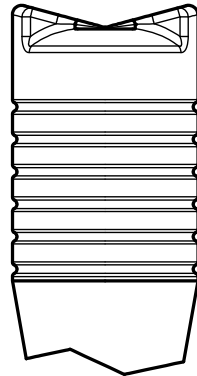

DC 12V x 8A

**0D** Stable top button

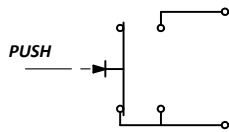
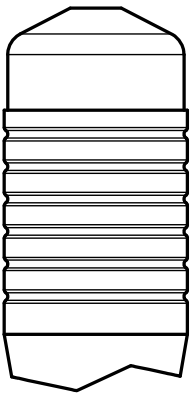

DC 28V x 10A resistive  
DC 28V x 5A  
Inductive

Front electric controls

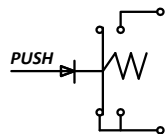
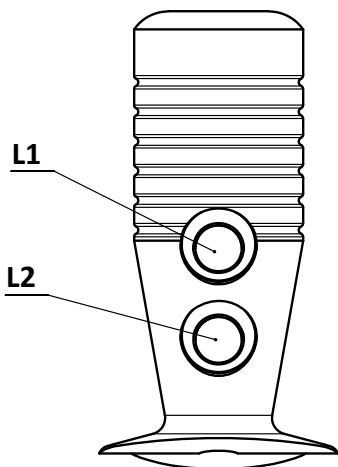

DC 28V x 5A resistive  
DC 28V x 3A  
Inductive

Configurations

Code	Description
<b>0</b>	No button
<b>F</b>	L1
<b>G</b>	L2
<b>H</b>	L1+L2

Upper electric controls

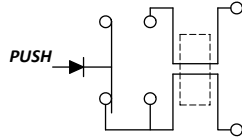
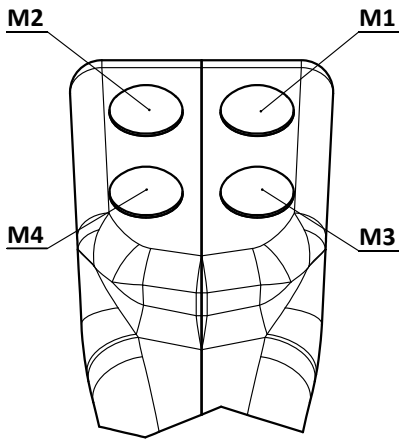

DC 12V x 4A resistive  
DC 12V x 2A  
Inductive

Configurations

Code	Description
<b>00</b>	No button
<b>01</b>	M1
<b>02</b>	M1+M2
<b>03</b>	M1+M2+M3
<b>04</b>	M1+M2+M3+M4
<b>05</b>	M2
<b>06</b>	M3+M4

Front electric controls

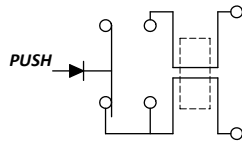
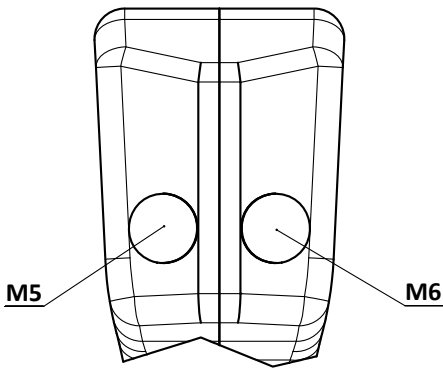

DC 12V x 4A resistive  
DC 12V x 2A  
Inductive

Configurations

Code	Description
<b>0</b>	No button
<b>1</b>	M5
<b>2</b>	M5+M6
<b>3</b>	M6

Upper electric controls

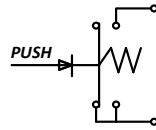
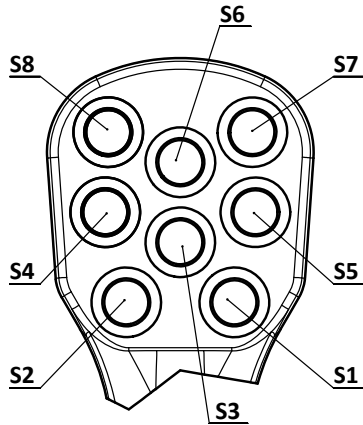

DC 28V x 5A resistive  
DC 28V x 3A  
Inductive

Configurations

Code	Description	Code	Description	Code	Description
<b>00</b>	No button	<b>0C</b>	S1+S2+S4+S5+S7+S8	<b>0P</b>	S1+S5+S7
<b>01</b>	S1	<b>0D</b>	S4+S8	<b>0Q</b>	S1+S2+S7+S8
<b>02</b>	S3	<b>0E</b>	S5	<b>0R</b>	S2+S4
<b>03</b>	S1+S2	<b>0F</b>	S4	<b>0S</b>	S3+S4+S5+S7+S8
<b>04</b>	S4+S5	<b>0G</b>	S5+S7	<b>0T</b>	S1+S7
<b>05</b>	S1+S2+S5	<b>0H</b>	S3+S4+S5+S6	<b>0U</b>	S3+S6
<b>06</b>	S1+S2+S4+S5	<b>0I</b>	S4+S5+S6	<b>0V</b>	S8
<b>07</b>	S1+S2+S3+S4+S5	<b>0J</b>	S1+S2+S3	<b>0W</b>	S2+S8
<b>08</b>	S1+S2+S3+S4+S5+S6	<b>0K</b>	S4+S5+S7+S8	<b>0Y</b>	S7+S8
<b>09</b>	S1+S2+S3+S4+S5+S7+S8	<b>0L</b>	S6	<b>0Z</b>	S1+S2+S6
<b>0A</b>	S1+S2+S3+S4+S5+S6+S7+S8	<b>0M</b>	S1+S2+S4+S5+S6	<b>1A</b>	S2+S4+S8
<b>0B</b>	S3+S7+S8	<b>0N</b>	S3+S7		

Upper electric controls and Left Roller

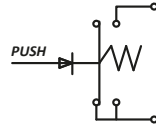
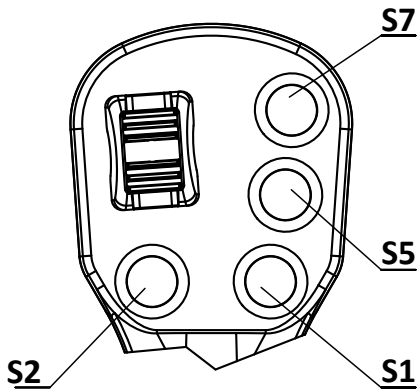

DC 28V x 5A resistive  
DC 28V x 3A  
Inductive

Configurations

Code	Description
<b>RA</b>	Left Roller
<b>RB</b>	Left Roller+S7
<b>RC</b>	Left Roller+S5+S7
<b>RD</b>	Left Roller+S1+S5+S7
<b>RE</b>	Left Roller+S1+S2+S5+S7

Upper electric controls and Right Roller

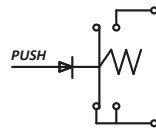
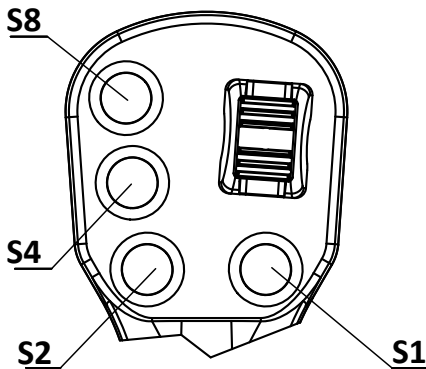

DC 28V x 5A resistive  
DC 28V x 3A  
Inductive

Configurations

Code	Description
<b>RF</b>	Right Roller
<b>RG</b>	Right Roller+S8
<b>RH</b>	Right Roller+S4+S8
<b>RJ</b>	Right Roller+S2+S4+S8
<b>RK</b>	Right Roller+S1+S2+S4+S8

Upper electric controls, Right Roller and Left Roller

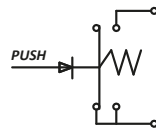
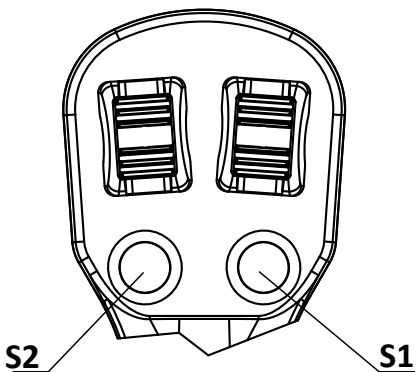

DC 28V x 5A resistive  
DC 28V x 3A  
Inductive

Configurations

Code	Description
<b>RL</b>	Right Roller+Left Roller
<b>RM</b>	Right Roller+Left Roller+S2
<b>RN</b>	Right Roller+Left Roller+S2+S1

Upper electric controls and Roller Up

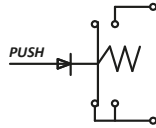
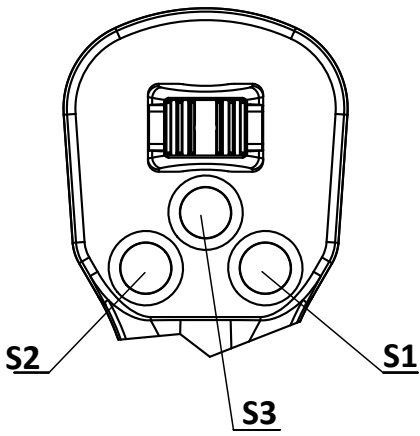

DC 28V x 5A resistive  
DC 28V x 3A  
Inductive

Configurations

Code	Description
<b>RO</b>	Roller Up+S1+S2
<b>RP</b>	Roller Up+S3
<b>RR</b>	Roller Up+S1+S2+S3

Roller Down

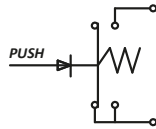
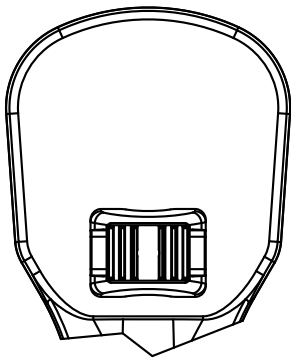

DC 28V x 5A resistive  
DC 28V x 3A  
Inductive

Configurations

Code	Description
<b>RQ</b>	Roller Down



Upper electric controls and Left Roller

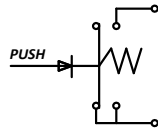
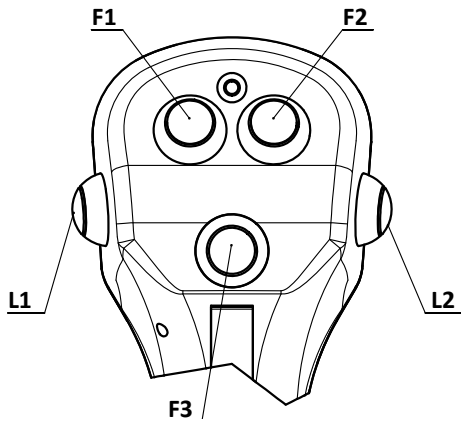

DC 28V x 5A resistive  
DC 28V x 3A  
Inductive

Configurations

Code	Description	Code	Description	Code	Description
<b>0</b>	No button	<b>5</b>	F2	<b>A</b>	F1+F2+L1+L2
<b>1</b>	L1	<b>6</b>	F3	<b>B</b>	F3+L1+L2
<b>2</b>	L2	<b>7</b>	F1+F2	<b>C</b>	F1+L1
<b>3</b>	L1+L2	<b>8</b>	F1+F2+F3	<b>D</b>	F1+F3
<b>4</b>	F1	<b>9</b>	F1+F2+F3+L1+L2	<b>E</b>	F1+F3+L1+L2

Front buttons are not foreseen for versions "V" and "Z".

**500** PWM output profile

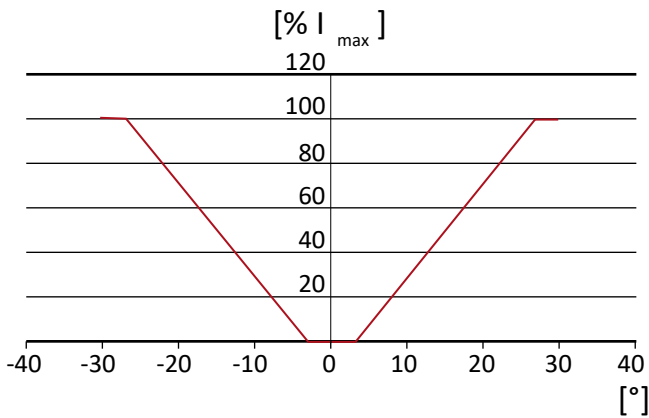

**501** PWM output profile

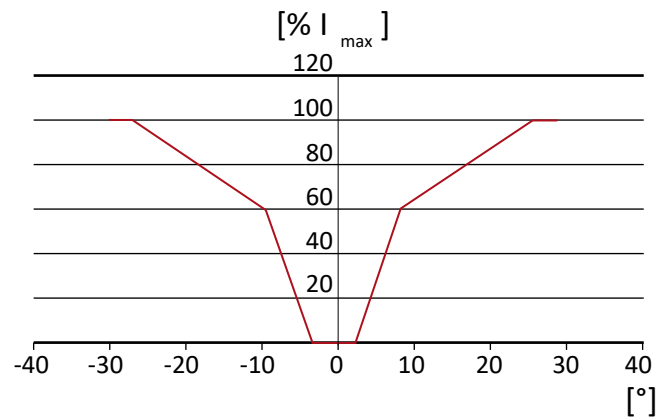

**502** PWM output profile

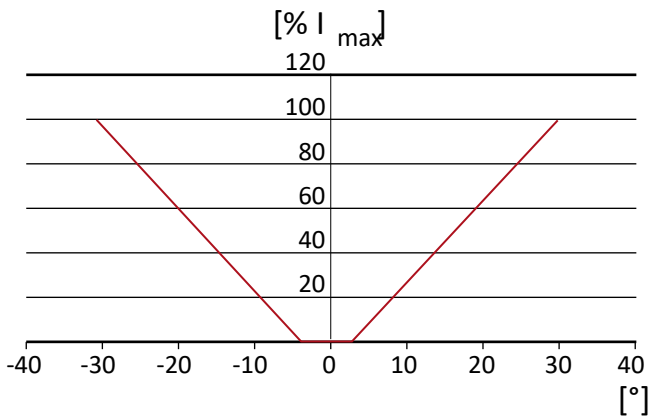

**503** PWM output profile

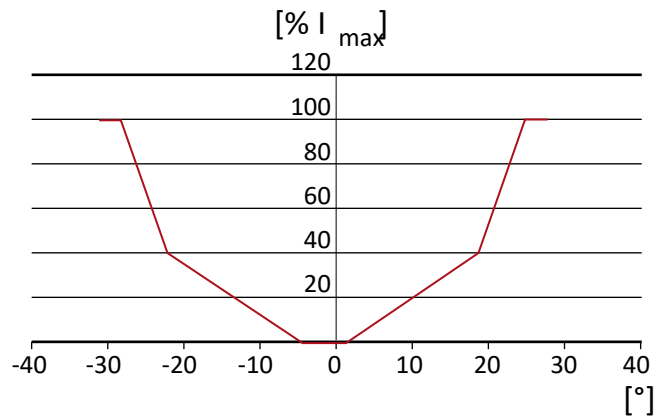

The programming of the electronic card, integrated in the H/T handle, is specific for each application as the ramp is designed to best meet the application working conditions. You will therefore have to ask HP Hydraulic to assign the 3-digit code once the application and the correct ramp has been agreed (current delivered, % I<sub>max</sub>, depending on the roller position, degrees). Below are examples of ramps available to the standard configuration of the parameters of voltage, current and PWM frequency of the electronic board.

PHJD	1	2	3	4	5	6	7	8	9	10	11	12	13	14	15	16	17	18
	0	G	2	1	K	S	S	0	1	0	0	0	0	0	0	0	0	0

1	<b>Models</b>	<b>1</b> 1 pressure signal from axis 2-4 <b>2</b> 2 pressure signals from axis 1-3 and 2-4	<b>3</b> Opposite counter rotation <b>4</b> 1 pressure signal from each position	<b>5</b> Opposite counter rotation with reverse signal <b>6</b> Concordant counter rotation	<b>7</b> Concordant counter rotation with reverse signal
2 3	<b>Ports</b>	<b>G2</b> 1/4" gas-BSPP	<b>U3</b> SAE 9/16"-18UNF		
4	<b>Seals</b>	<b>1</b> NBR	<b>2</b> Viton		
5	<b>Grips</b>	<b>0</b> Without handle <b>S</b> Anatomical <b>K</b> Cylindrical	<b>E</b> Ergonomic <b>F</b> Ergonomic deadman <b>T</b> Multifunctional	<b>H</b> Multifunctional Deadman <b>V</b> Multifunctional PWM output <b>Z</b> Multifunctional PWM output Deadman	
6	<b>Positioner</b>	<b>S</b> With spring return to centre <b>A</b> Clutch controlled forward/back 2-4	<b>M</b> Mechanical position 4 <b>E</b> Electromagnetic position 4 12 V	<b>F</b> Electromagnetic position 4 24 V	
7 8 9	<b>Adjustment curve</b>	<b>S</b> Single ramp with step <b>L</b> Single ramp without step	<b>M</b> Double ramp with step <b>G</b> Double ramp without step		
10 11	<b>Upper electric controls</b>	<b>00</b> No button	<b>...</b> See upper electric controls		
12	<b>Front electric controls</b>	<b>0</b> No switch	<b>...</b> See front electric controls		
13 14 15	<b>Special versions</b>	<b>000</b> No special execution	<b>001</b> Lever inclined right by 15°	<b>002</b> Lever inclined left by 15°	
16 17 18	<b>PWM output profile programming (A)</b>	<b>000</b> No PWM signal <b>500</b> PWM output profile	<b>501</b> PWM output profile <b>502</b> PWM output profile	<b>503</b> PWM output profile	

**S A**

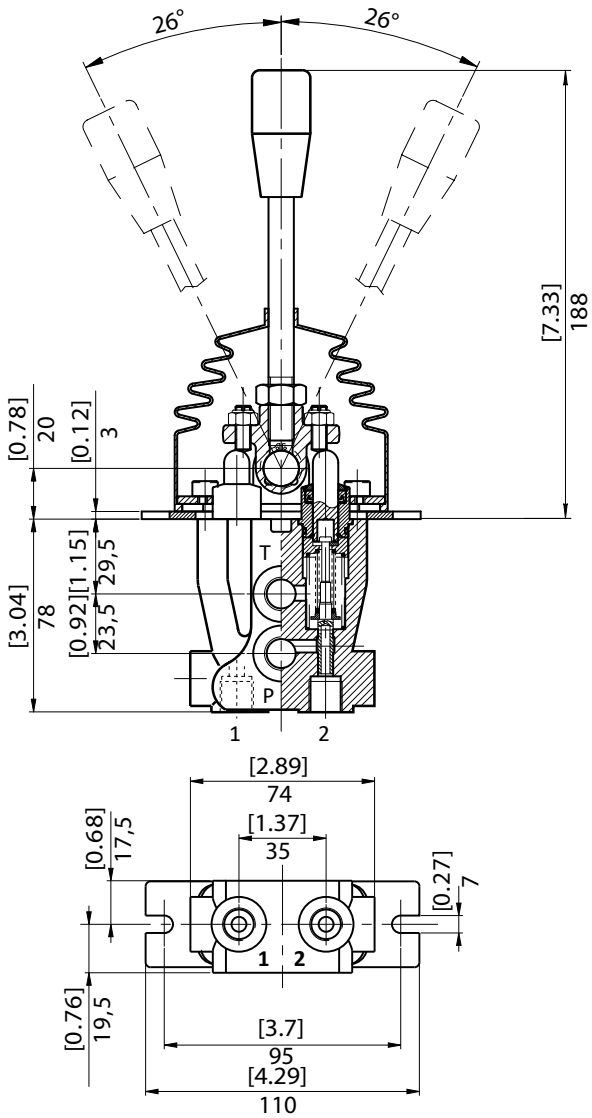

**B C**

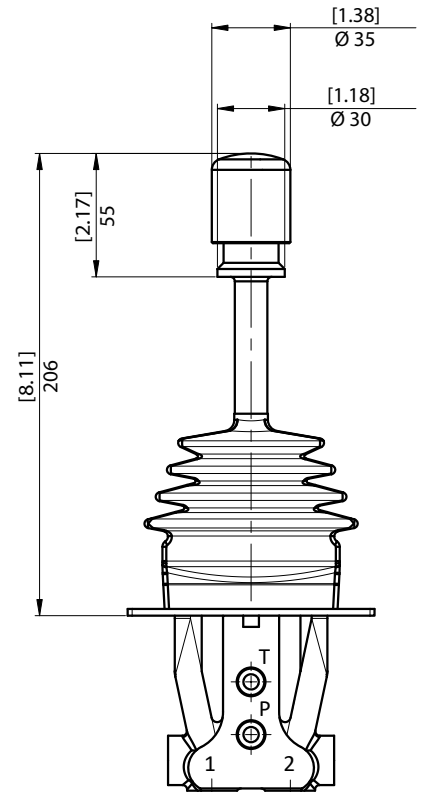

<b>1</b>	PORTS
<b>2</b>	PORTS
<b>T</b>	TANK
<b>P</b>	INLET

Direction of actuation

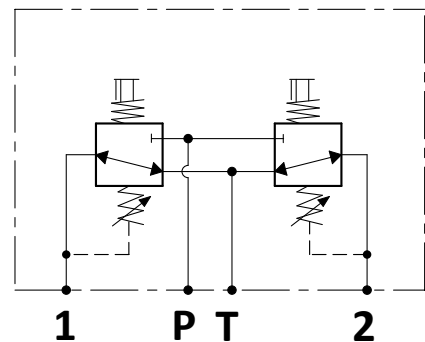
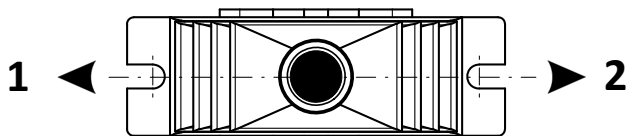

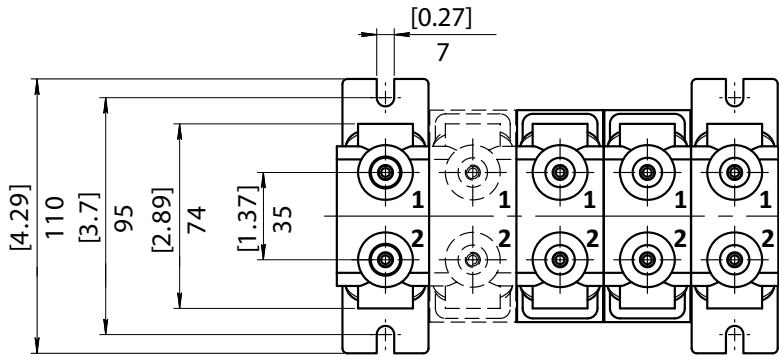

From 1 to sections

- 1** N° 1 Section
- 2** N° 2 Section
- 3** N° 3 Section
- 4** N° 4 Section
- 5** N° 5 Section
- 6** N° 6 Section
- 7** N° 7 Section
- 8** N° 8 Section
- 9** N° 9 Section
- A** N° 10 Section
- B** N° 11 Section
- C** N° 12 Section

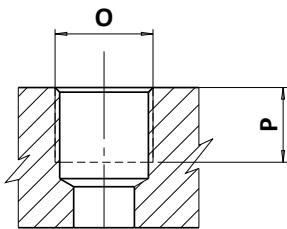
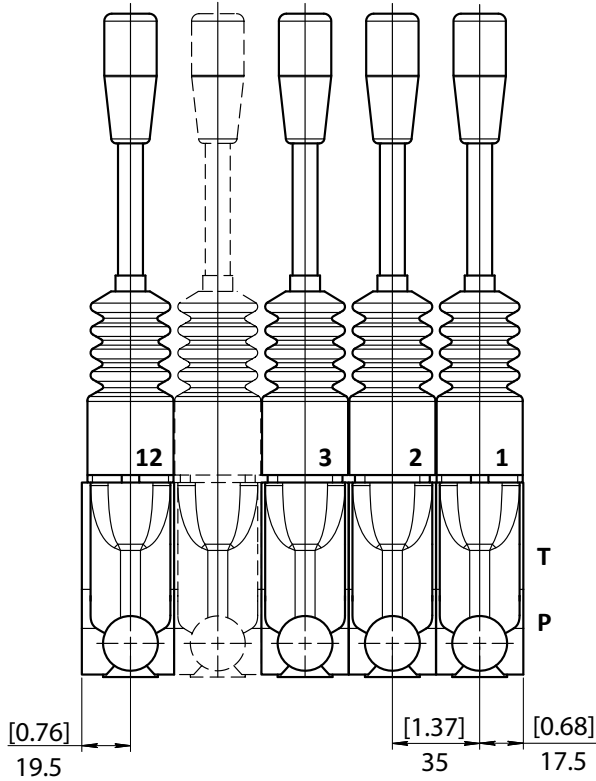
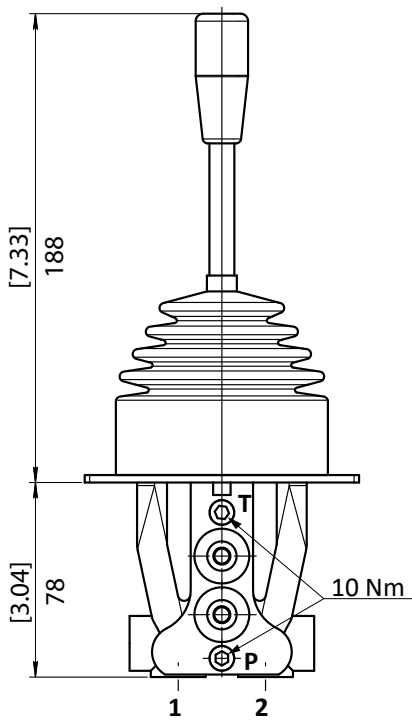

PORTS

TYPE	O		P	
		Nm	mm	in
<b>G2</b>	1/4"	17	12	0,47
<b>U3</b>	9/16-18 UNF	25	13	0,47

**S** Standard with spring back

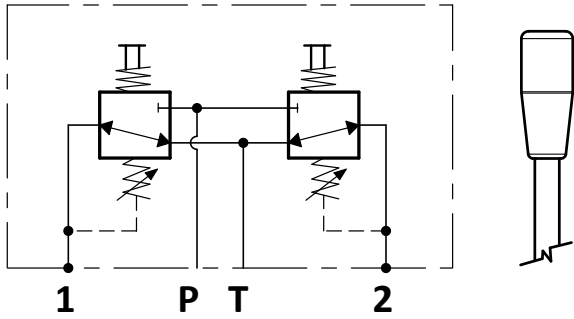

**A** Clutch controlled

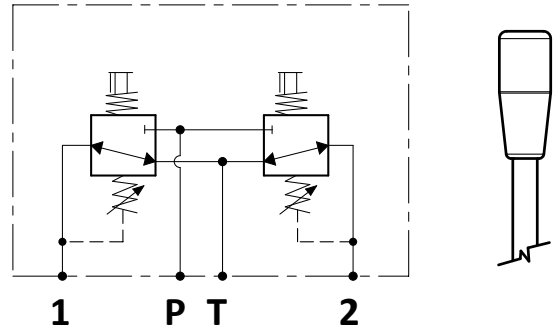

**L** Central with spring back

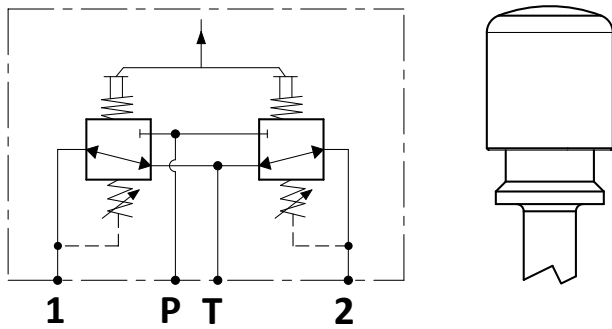

**F** Central clutch controlled

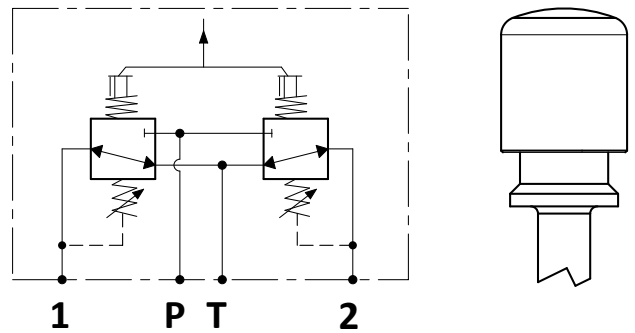

**Q** Mechanical detent pos. 2

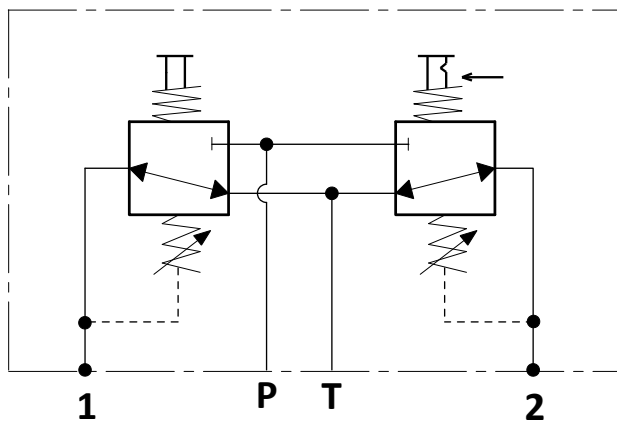

**D** Mechanical detent pos. 1-2

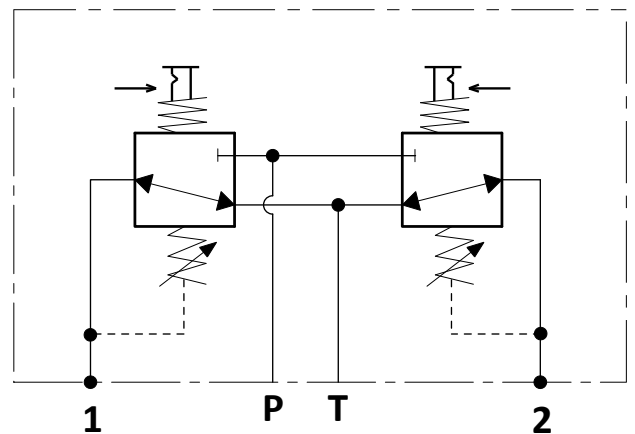

**U** Mechanical detent pos. 2  
clutch controlled

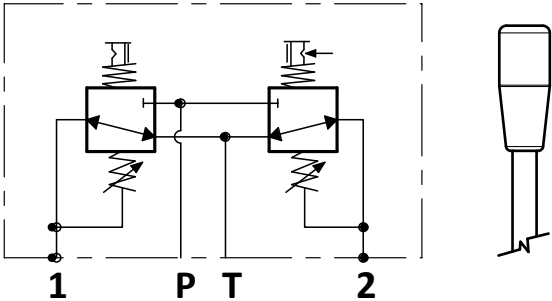

**Y** Mechanical detent pos. 1-2  
clutch controlled

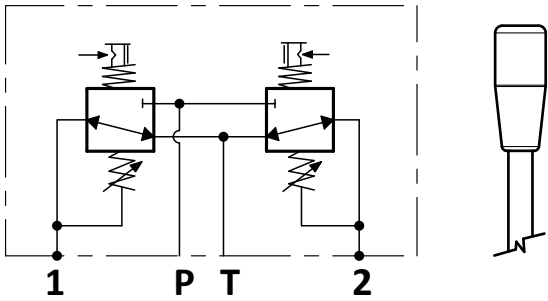

**S..** With step

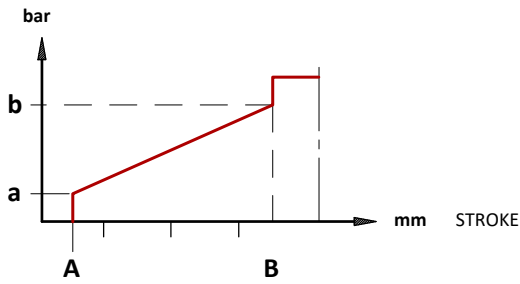

**L..** Without step

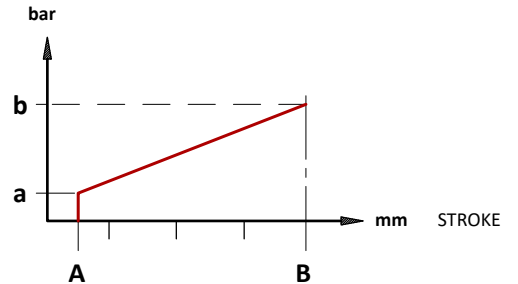

**M..** With step

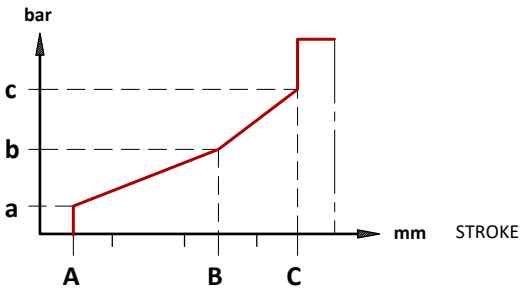

**G..** Without step

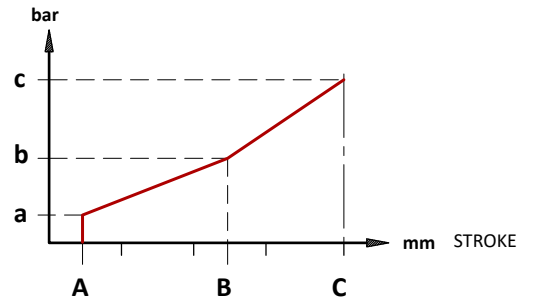

### Adjustment curves

TYPE	PRESSURE			
	a		b	
S	bar	psi	bar	psi
S00	2	29	16	232
S01	5	73	20	290
S02	6,5	94	24,5	355
S04	3	46	17	249
S08	5	73	16	232
S11	4	58	15	218
S12	1,5	22	7	102
S13	5	73	28	406

TYPE	PRESSURE						STROKE		
	a		b		c		A	B	C
M	bar	psi	bar	psi	bar	psi	mm	mm	mm
M60	5	73	12	174	21	306	1,2	5,4	7,8

TYPE	PRESSURE						STROKE		
	a		b		c		A	B	C
G	bar	psi	bar	psi	bar	psi	mm	mm	mm
G60	5	73	12	174	23	334	1,2	5,4	8,3

TYPE	PRESSURE			
	a		b	
L	bar	psi	bar	psi
L00	2	29	18	261
L01	5	73	22	319
L02	6,5	94	26,5	384
L04	3	46	19	276
L08	5	73	18	261
L11	4	58	15	218
L12	1,5	22	9	131
L13	5	73	30	435



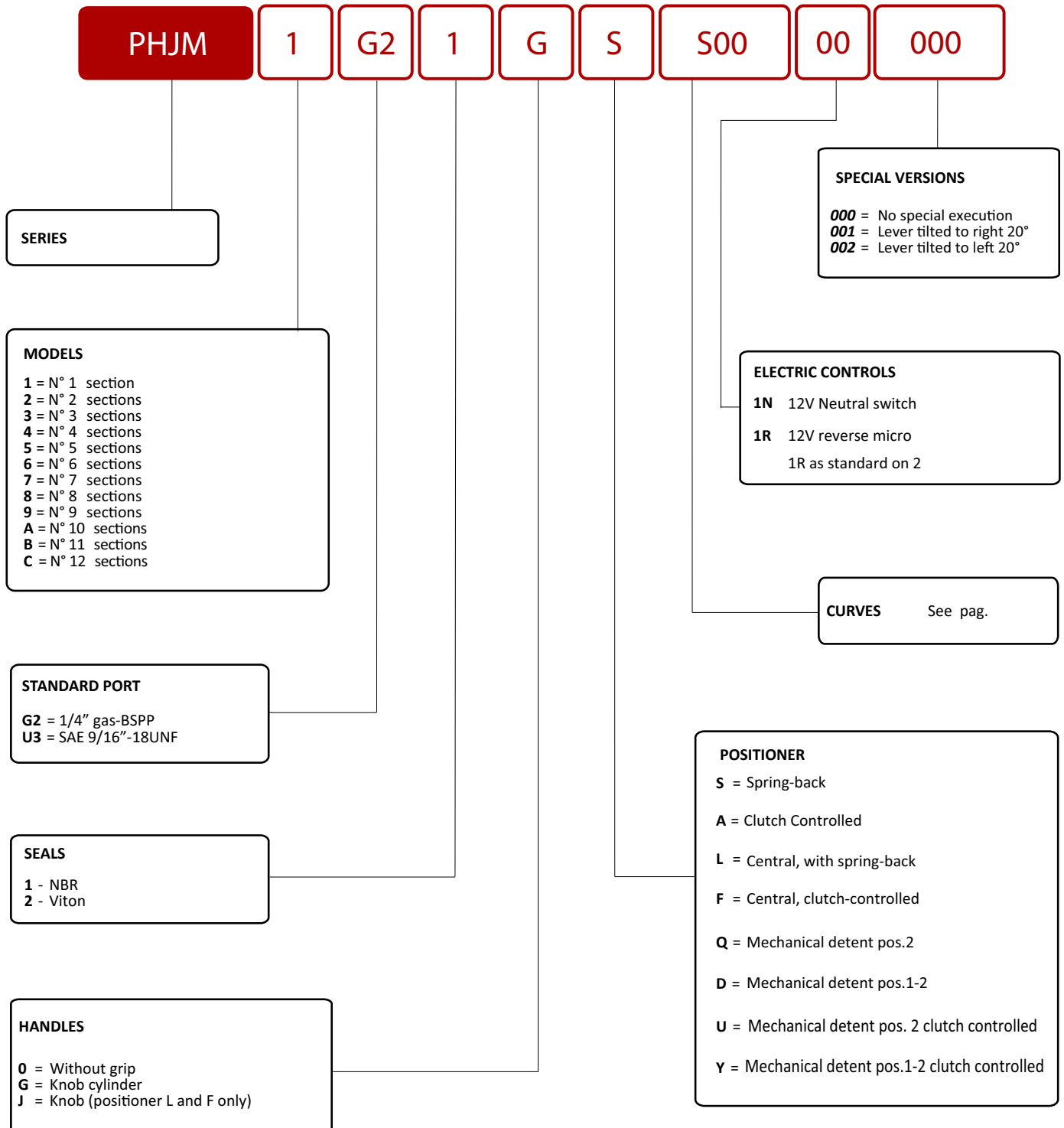

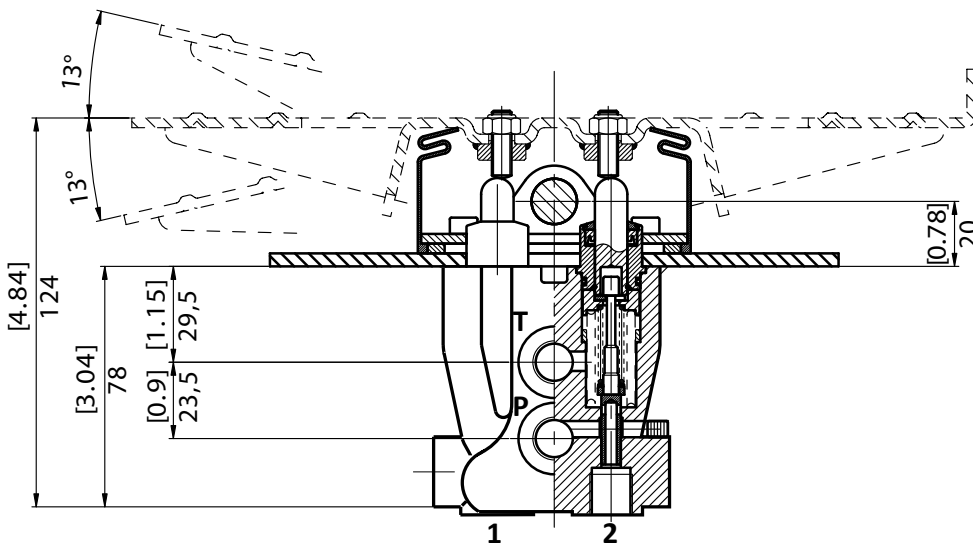
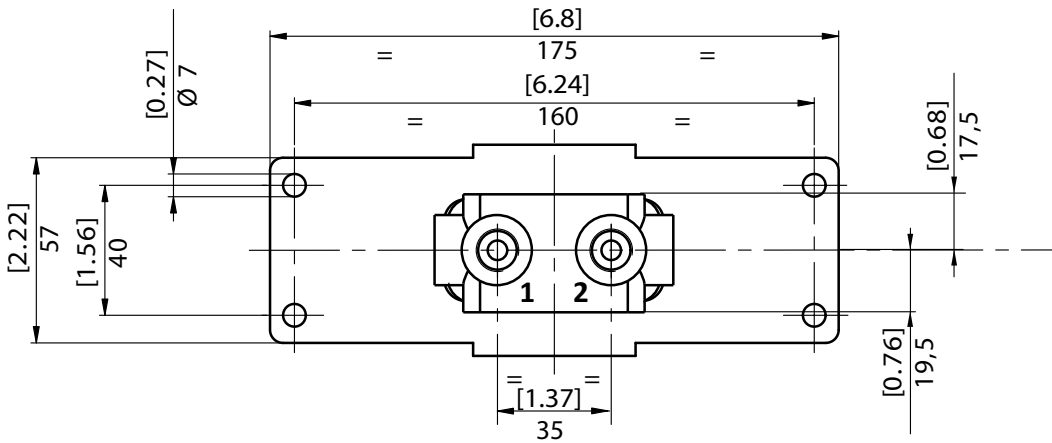

<b>1</b>	PORTS
<b>2</b>	PORTS
<b>T</b>	TANK
<b>P</b>	INLET

Direction of actuation

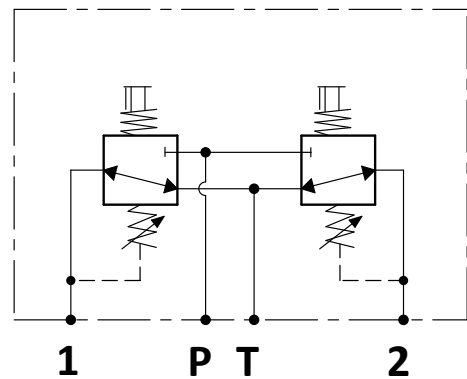
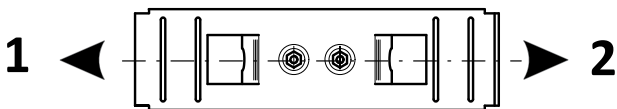

**0** Standard

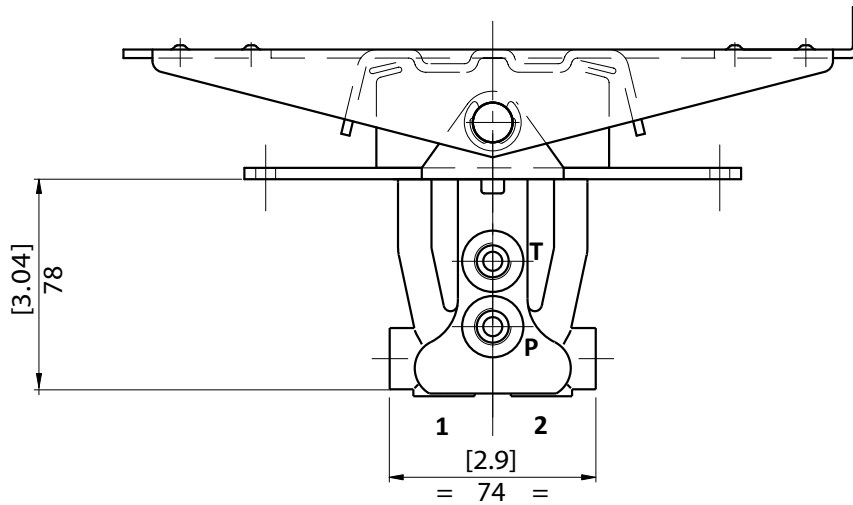

**2** Long step (pedals 1 - 4 only)

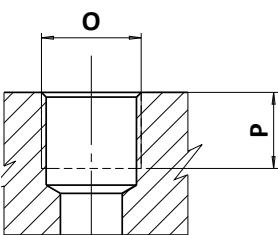
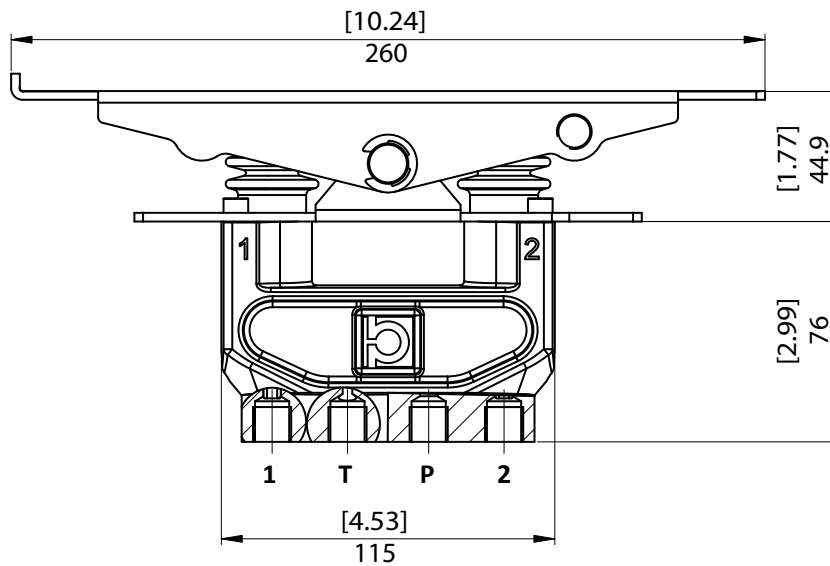

PORTS

TYPE	O	P		
		Nm	mm	in
<b>G2</b>	1/4"	17	12	0,47
<b>U3</b>	9/16-18 UNF	25	13	0,47

**3** With directional electric valves (pedals D - W only)

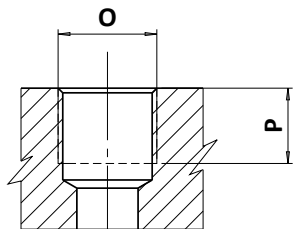
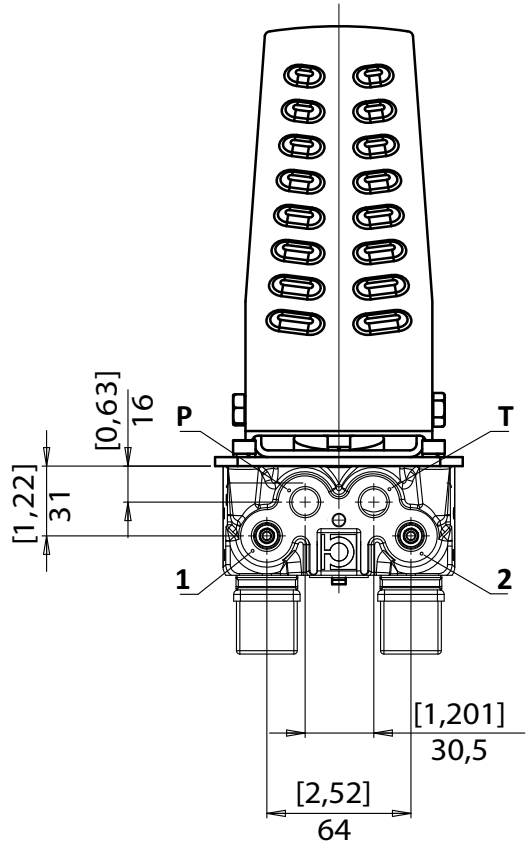
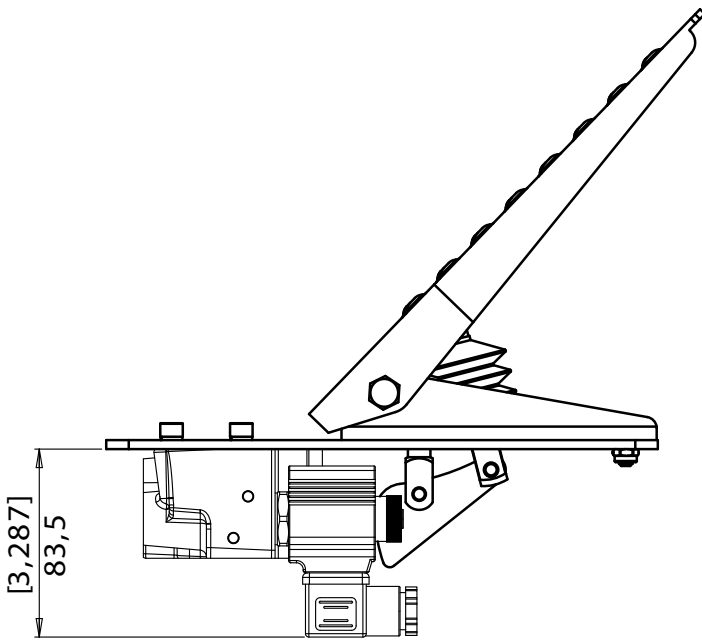

PORTS

TYPE	O	P	
		Nm	in
<b>G2</b>	1/4"	17	0,47
<b>U3</b>	9/16-18 UNF	25	0,47

**1** Standard toggle pedal

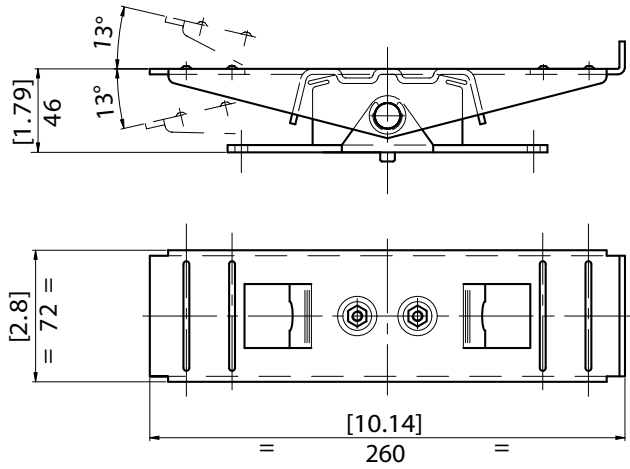

**2** Standard short pedal

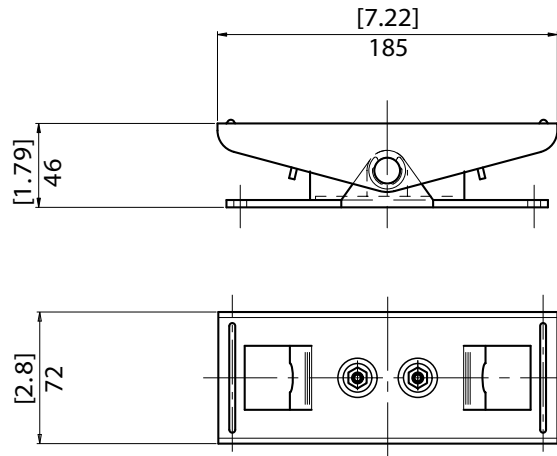

**3** Convex short pedal

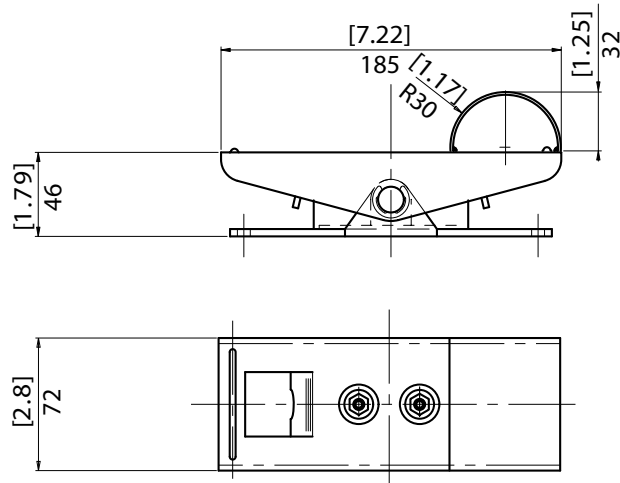

**4** Pedal with shim

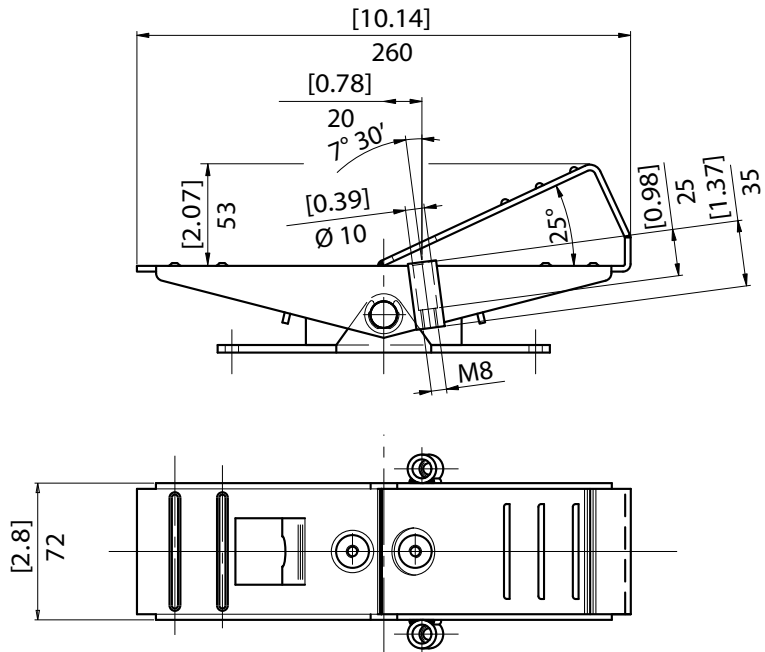

**5** Pedal with high shim

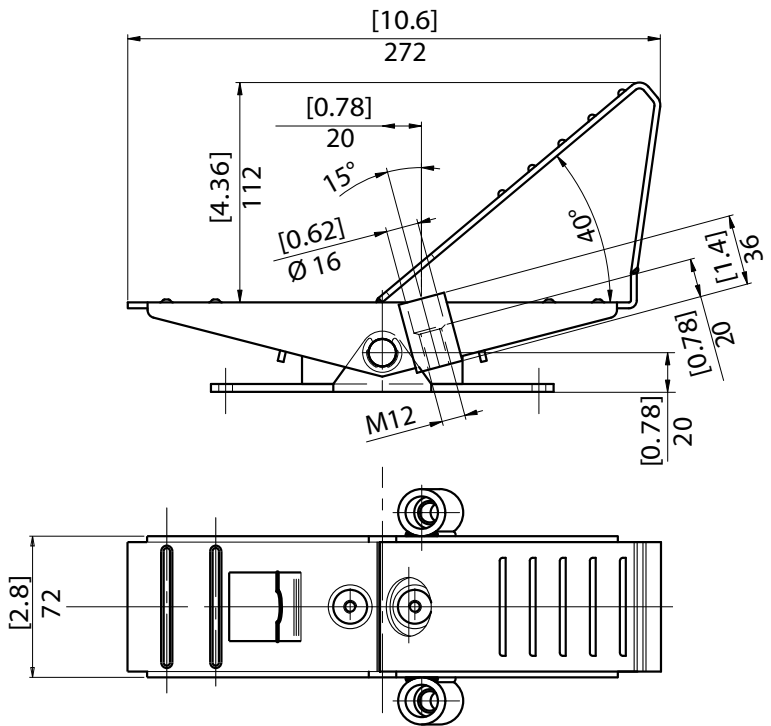

**6** Single right pedal

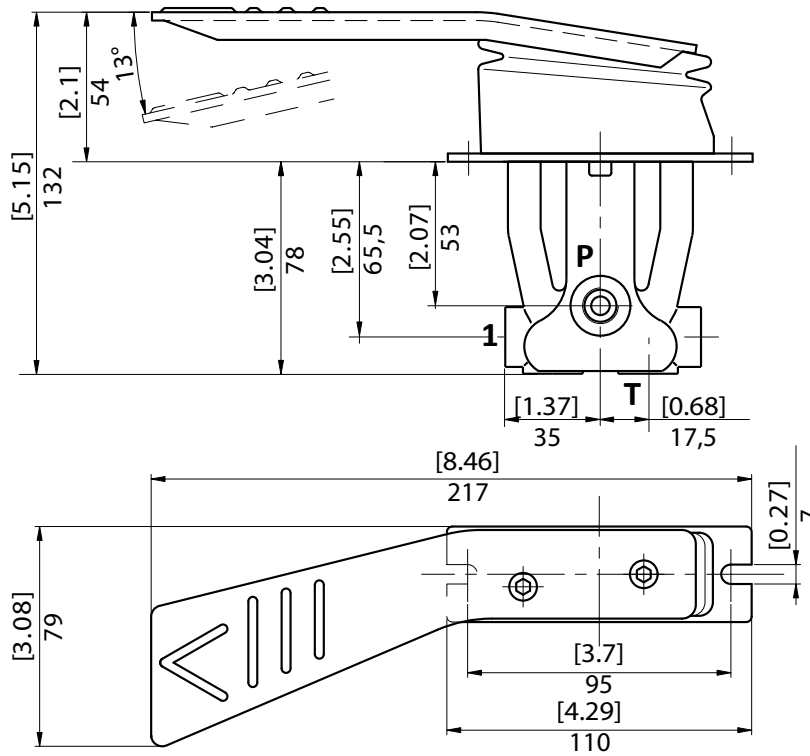

**7** Single left pedal

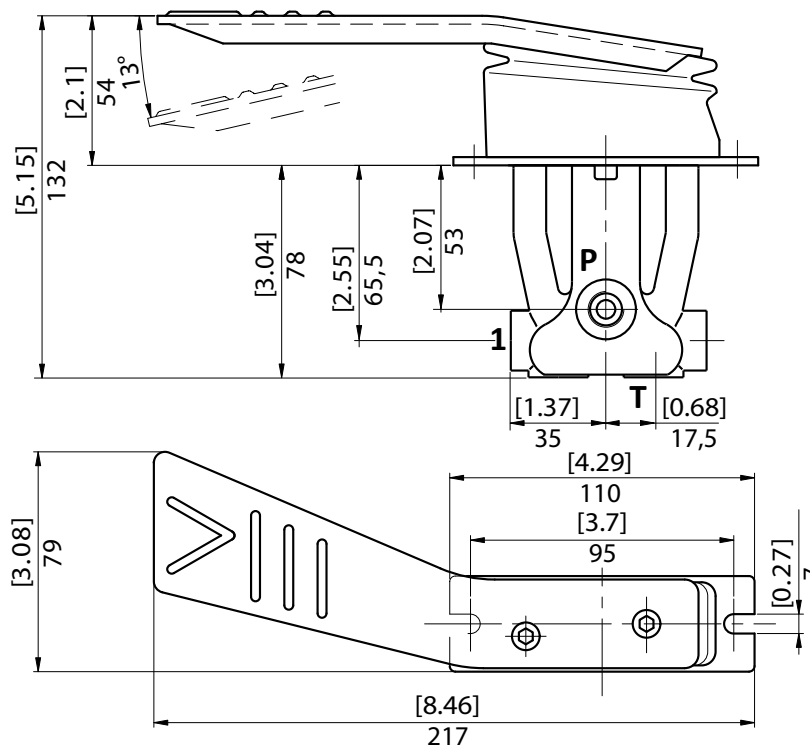

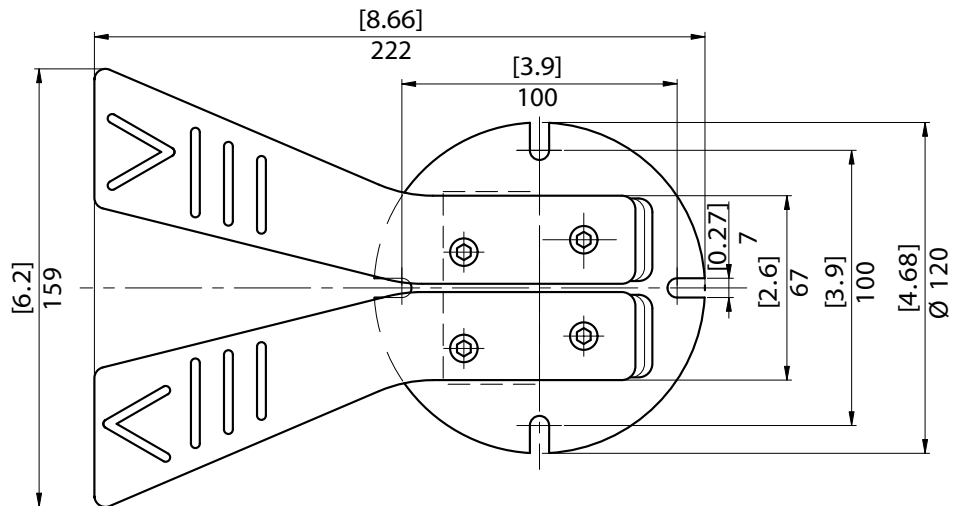
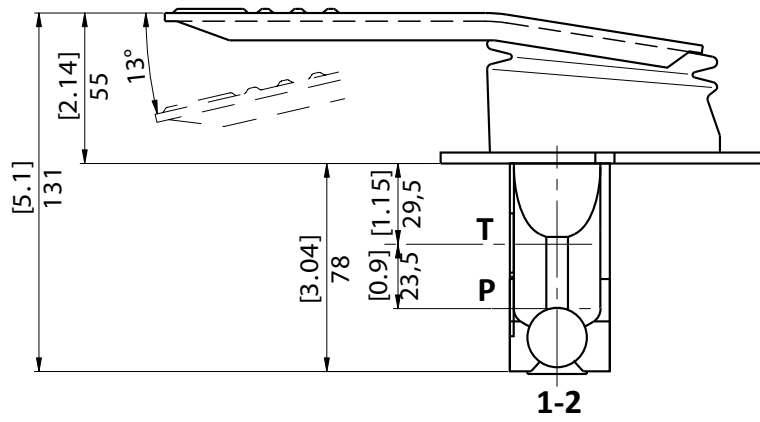
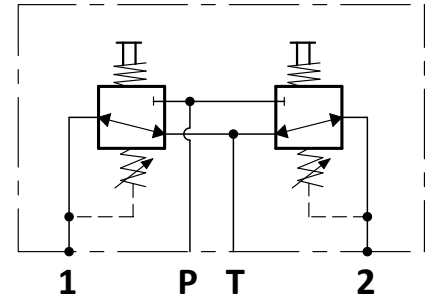
**8** Double pedal



**9** Button pedal

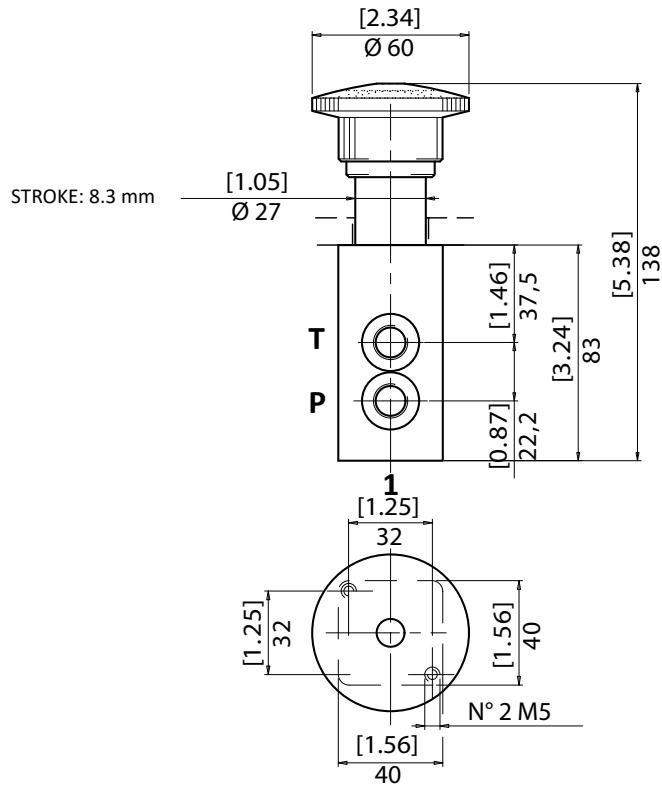

**R** Pression regulator

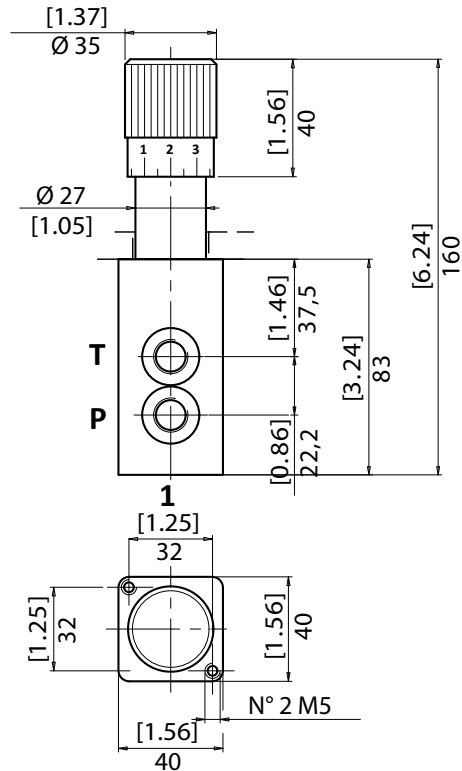

**N** Negative single pedal negative

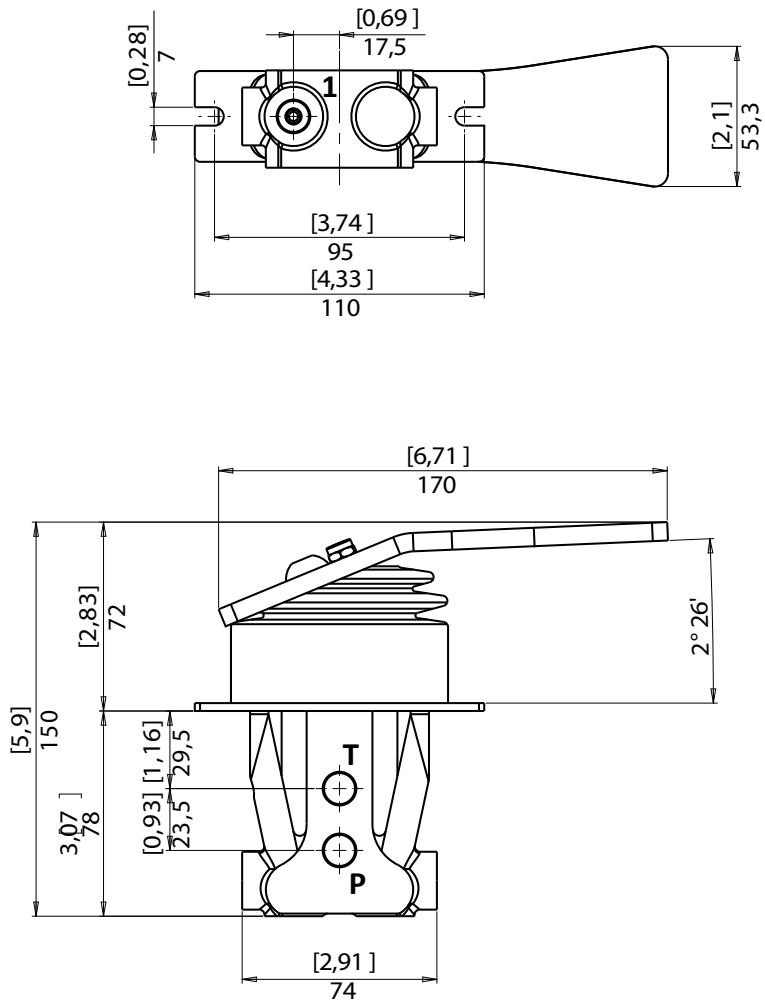
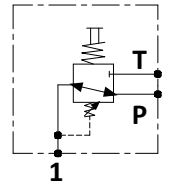

**V** Negative toggle lever pedal

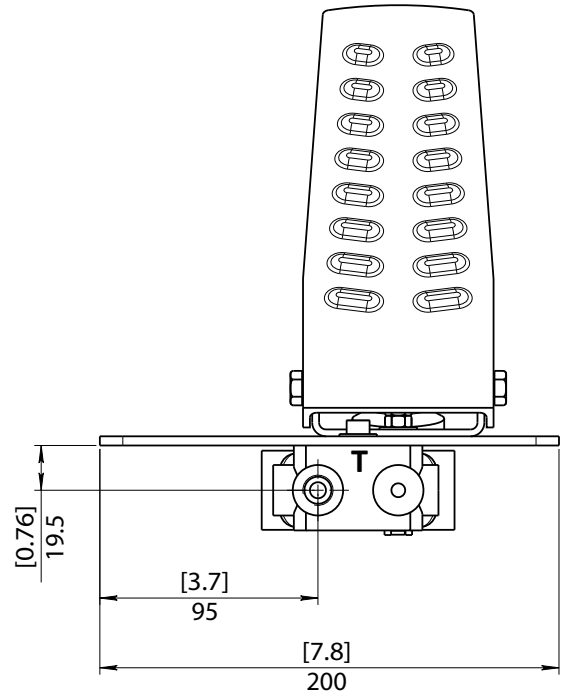
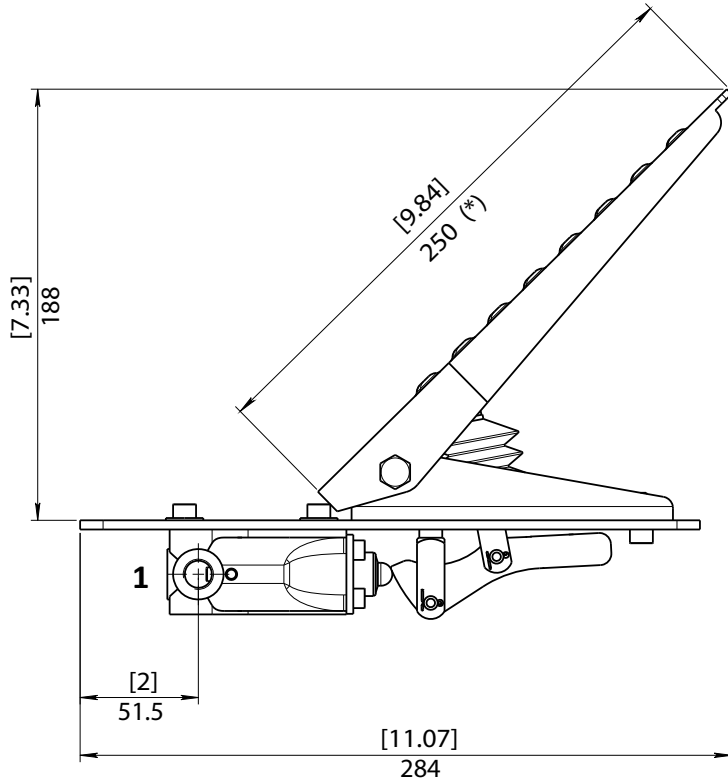
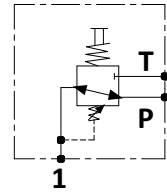
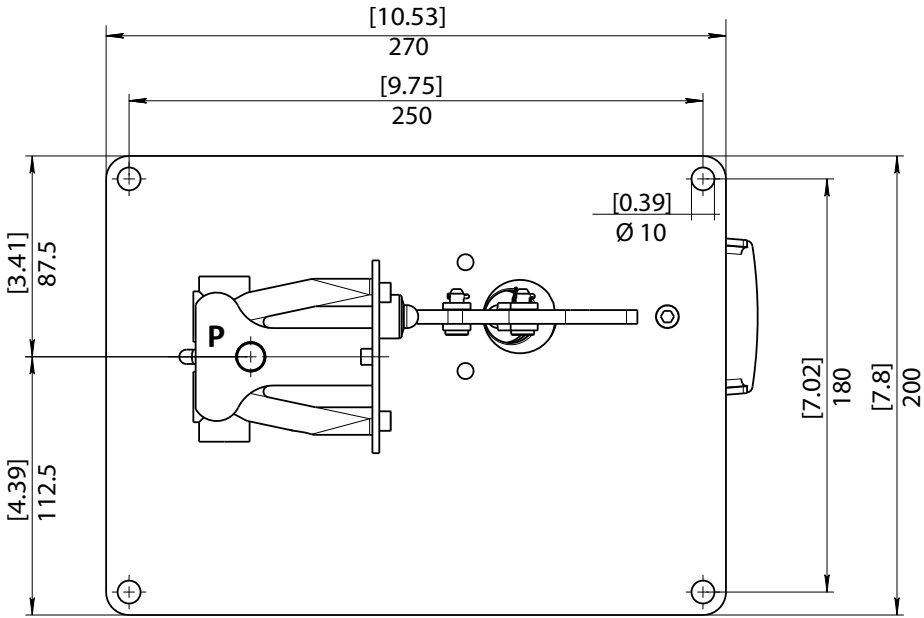

**X** Positive long toggle lever pedal

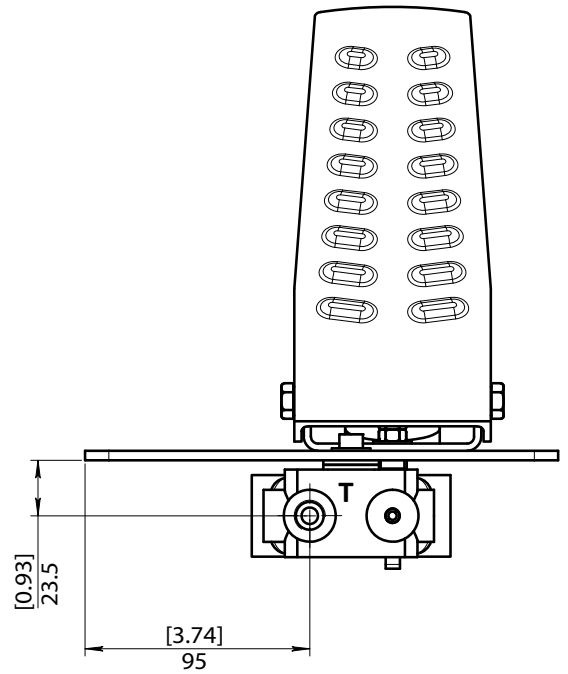
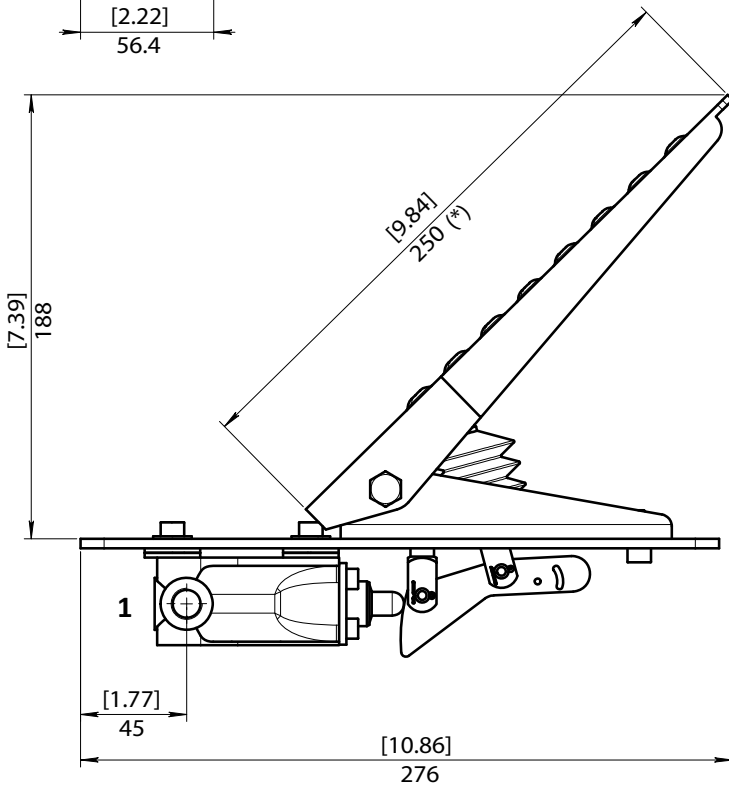
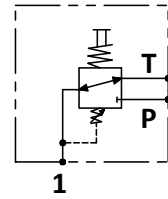
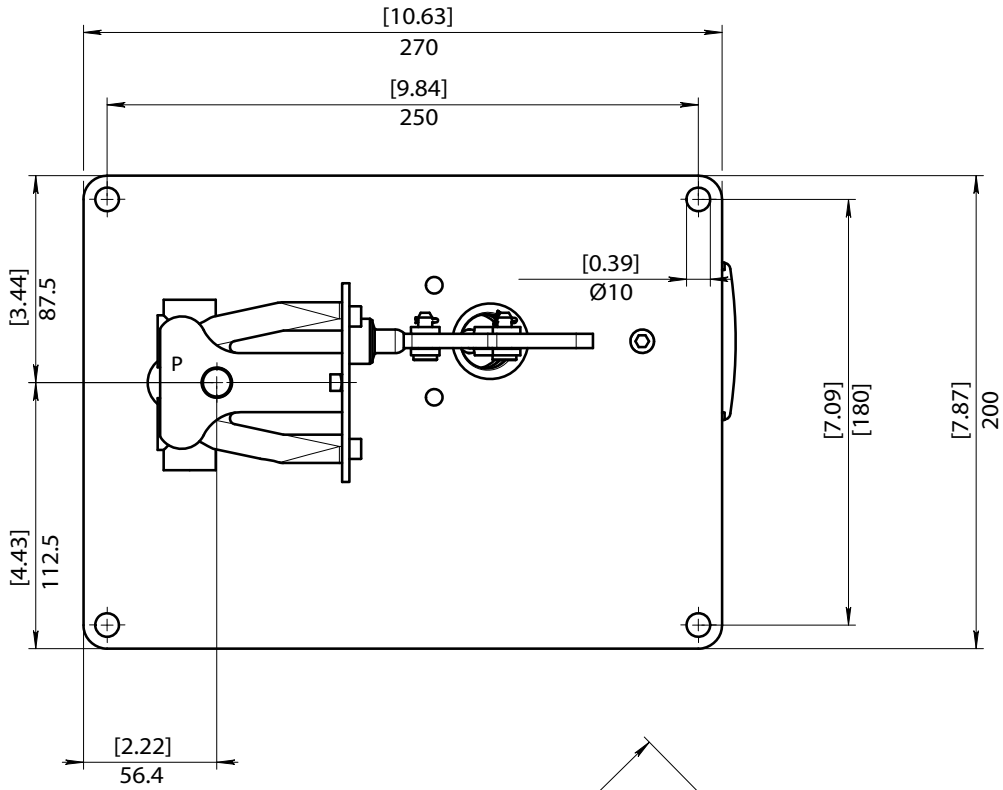

**W** Long toggle lever pedal with directional electrovalves

**FEATURES COIL**

Voltage (V)	Current draw (A)	Power (W)	Resistance (Ω)
12VDC +5/-10%	1.9	22.8	6.3(20°) -9.2+/-7% IP:65
24VDC +5/-10%	0.95	22.5	25.6(20°) -37+/-7% IP:65

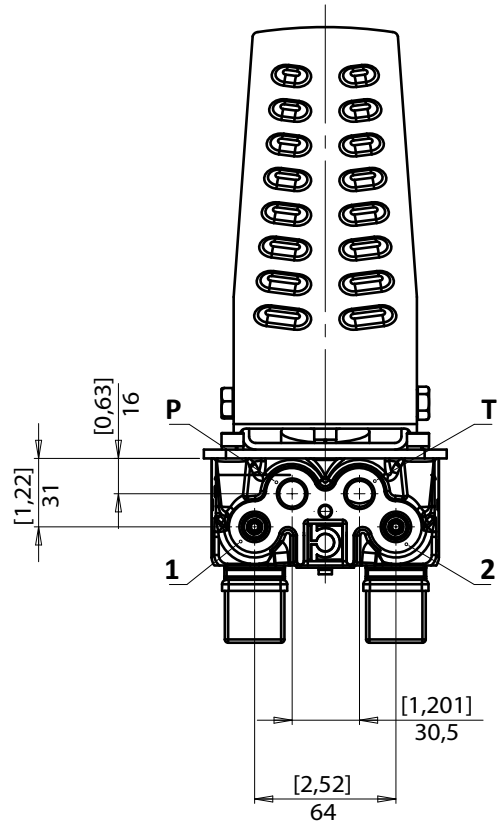
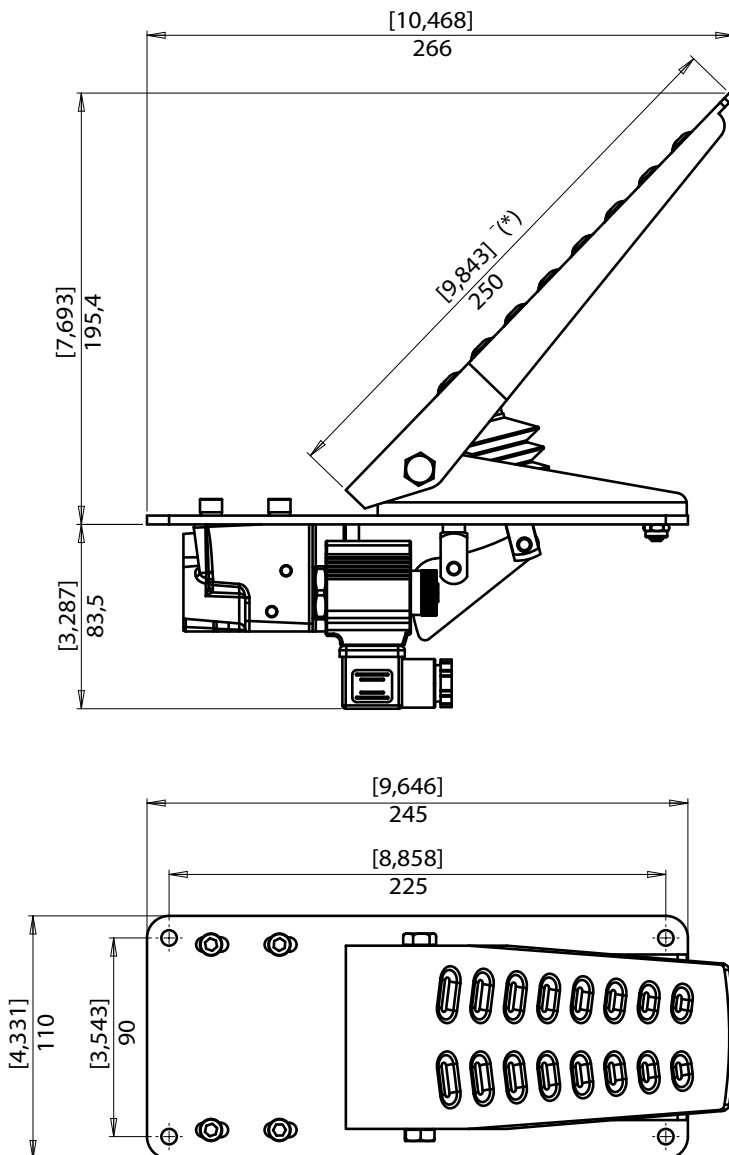
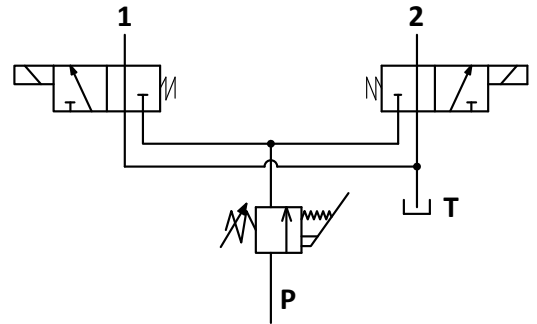

(\*Available in a version with pedal length 190 mm too

**Z** Resin toggle lever pedal

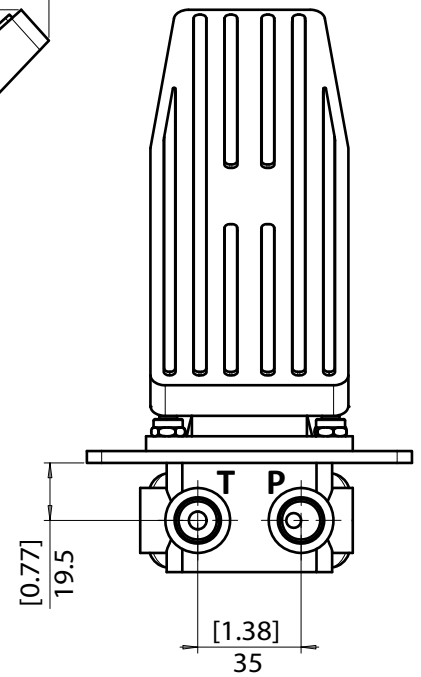
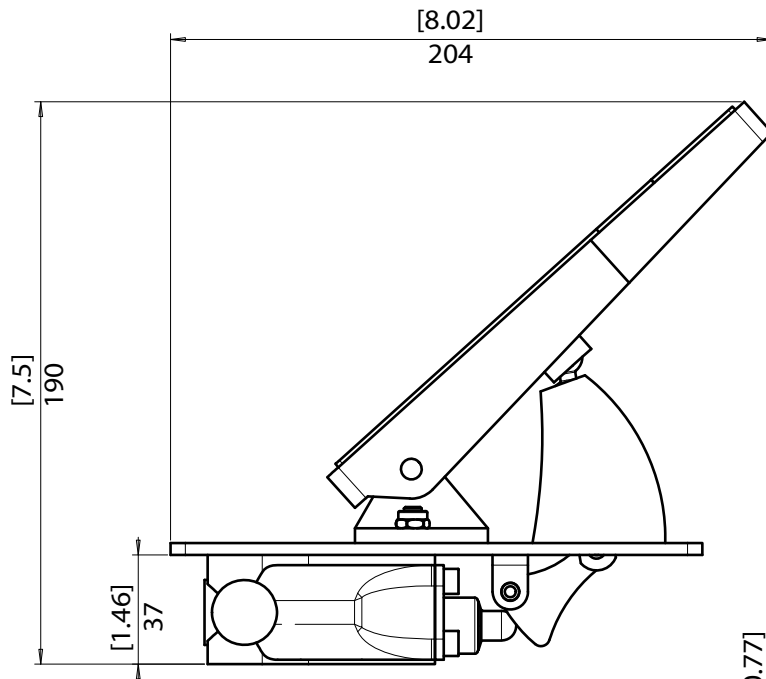
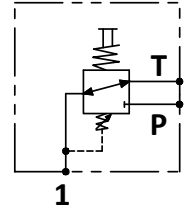
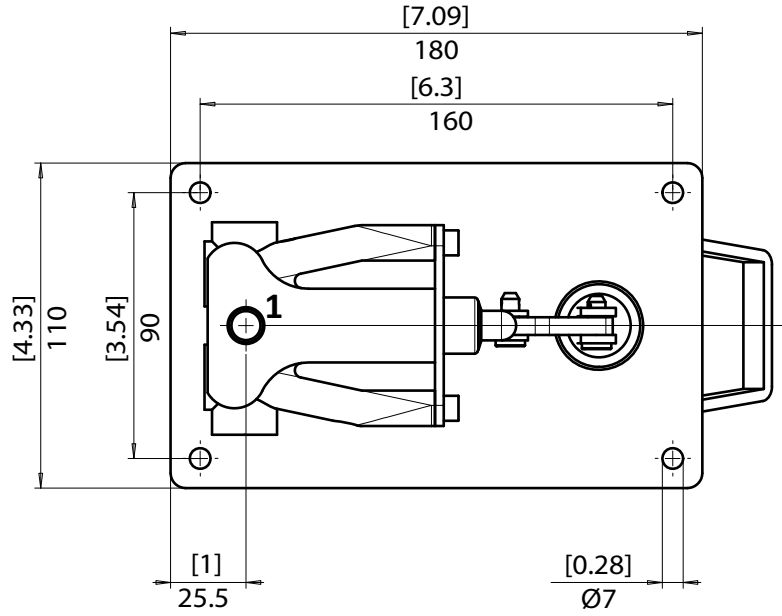

**D** Resin toggle lever pedal with directional electrovalves

FEATURES COIL

Voltage (V)	Current draw (A)	Power (W)	Resistance ( $\Omega$ )
12VDC +5/-10%	1.9	22.8	6.3(20°) -9.2+/-7% IP:65
24VDC +5/-10%	0.95	22.5	25.6(20°) -37+/-7% IP:65

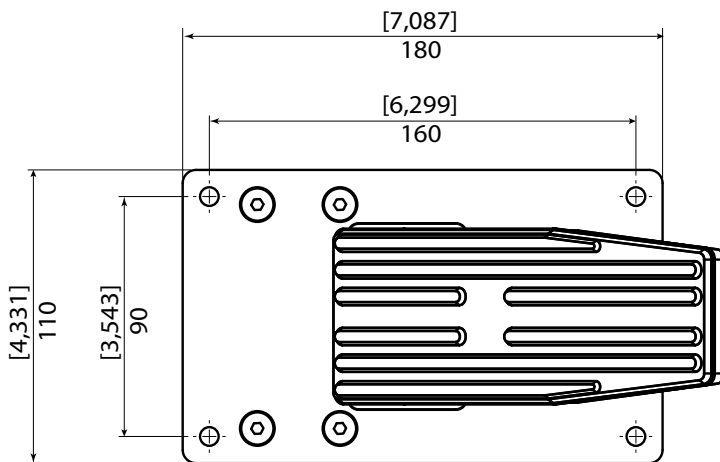
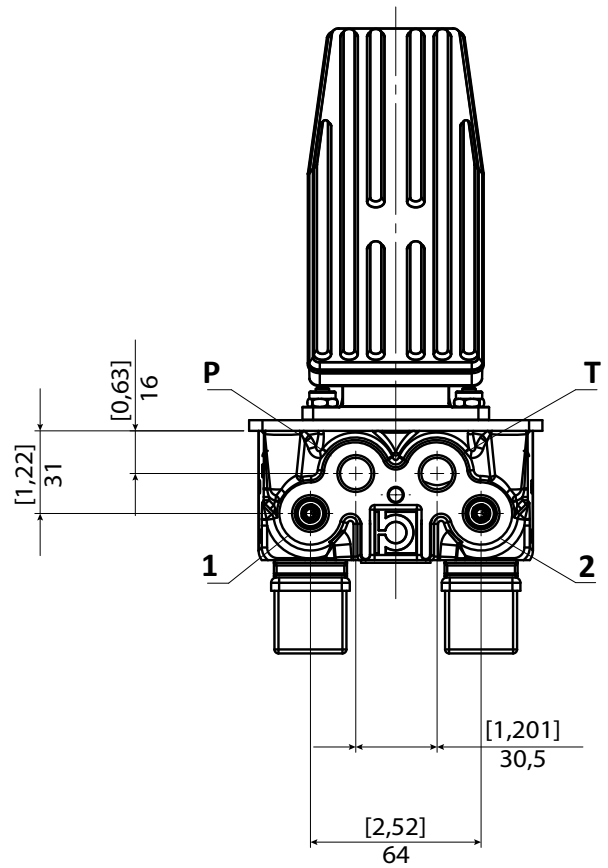
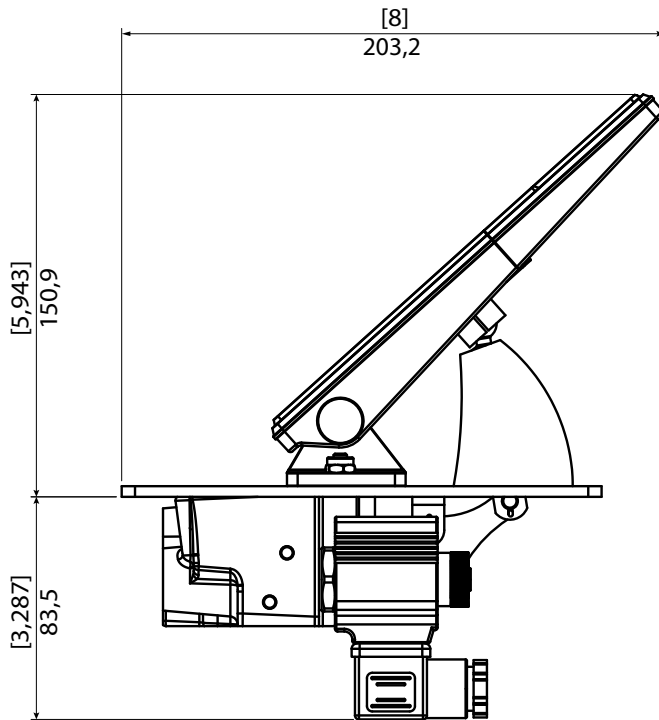
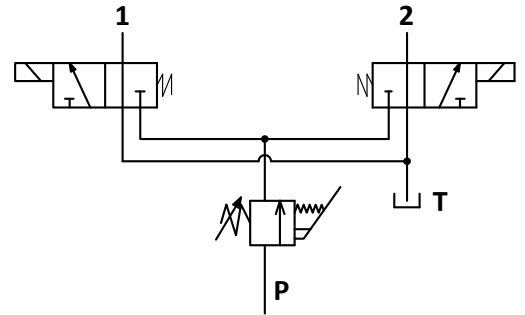

Single slope pressure curves

**P..** With step

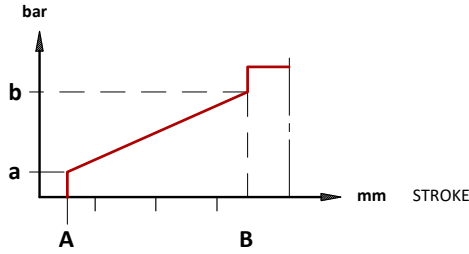

**R..** Without step

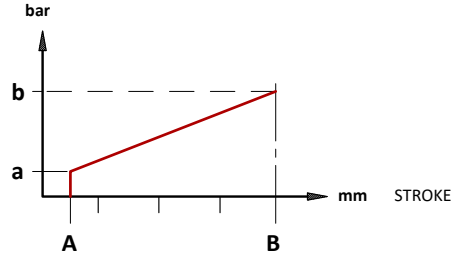

Adjustment curves

TYPE	PRESSURE			
	a		b	
P	bar	psi	bar	psi
P00	2	29	16	232
P01	3	43	18	261

TYPE	PRESSURE			
	a		b	
R	bar	psi	bar	psi
R00	2	29	18	261
R01	3	44	22	290

**Pressure curves for 9, R, D, HPCF1**

Single slope pressure curves

**S..** With step

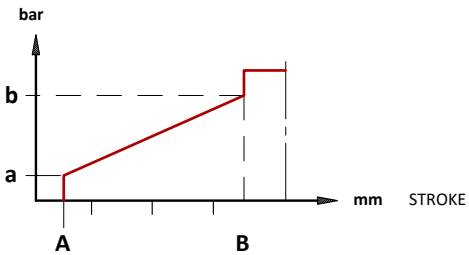

**L..** Without step

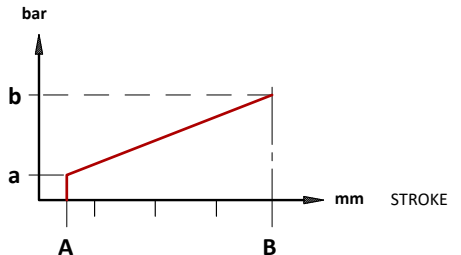

Adjustment curves

TYPE	PRESSURE			
	a		b	
S	bar	psi	bar	psi
S00	2	29	16	232
S01	5	73	20	290
S02	6,5	94	24,5	355
S04	3	46	17	249
S08	5	73	16	232
S11	4	58	15	218
S12	1,5	22	7	102
S13	5	73	28	406

TYPE	PRESSURE			
	a		b	
L	bar	psi	bar	psi
L00	2	29	18	261
L01	5	73	22	319
L02	6,5	94	26,5	384
L04	3	46	19	276
L08	5	73	18	261
L11	4	58	15	218
L12	1,5	22	9	131
L13	5	73	30	435



Single slope pressure curves

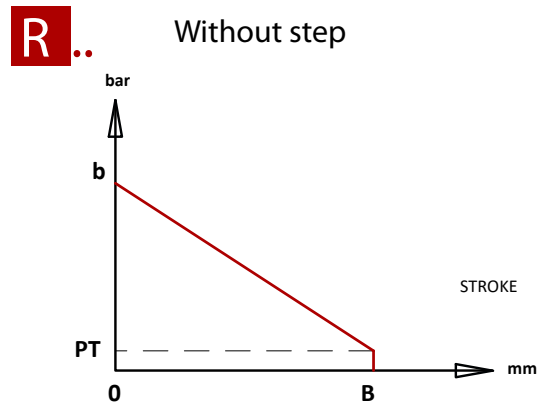
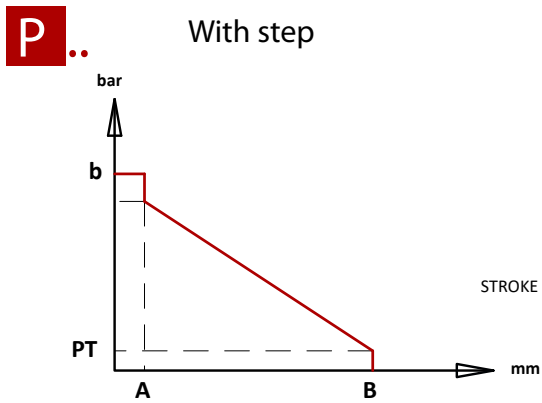

Adjustment curves

TYPE	PRESSURE			PT
	bar	b	psi	
<b>P00</b>	16		232	PT
<b>P01</b>	18		261	

TYPE	PRESSURE			PT
	bar	b	psi	
<b>R00</b>	16		261	PT
<b>R01</b>	22		290	

# PHP Proportional hydraulic pedal

## Ordering instructions

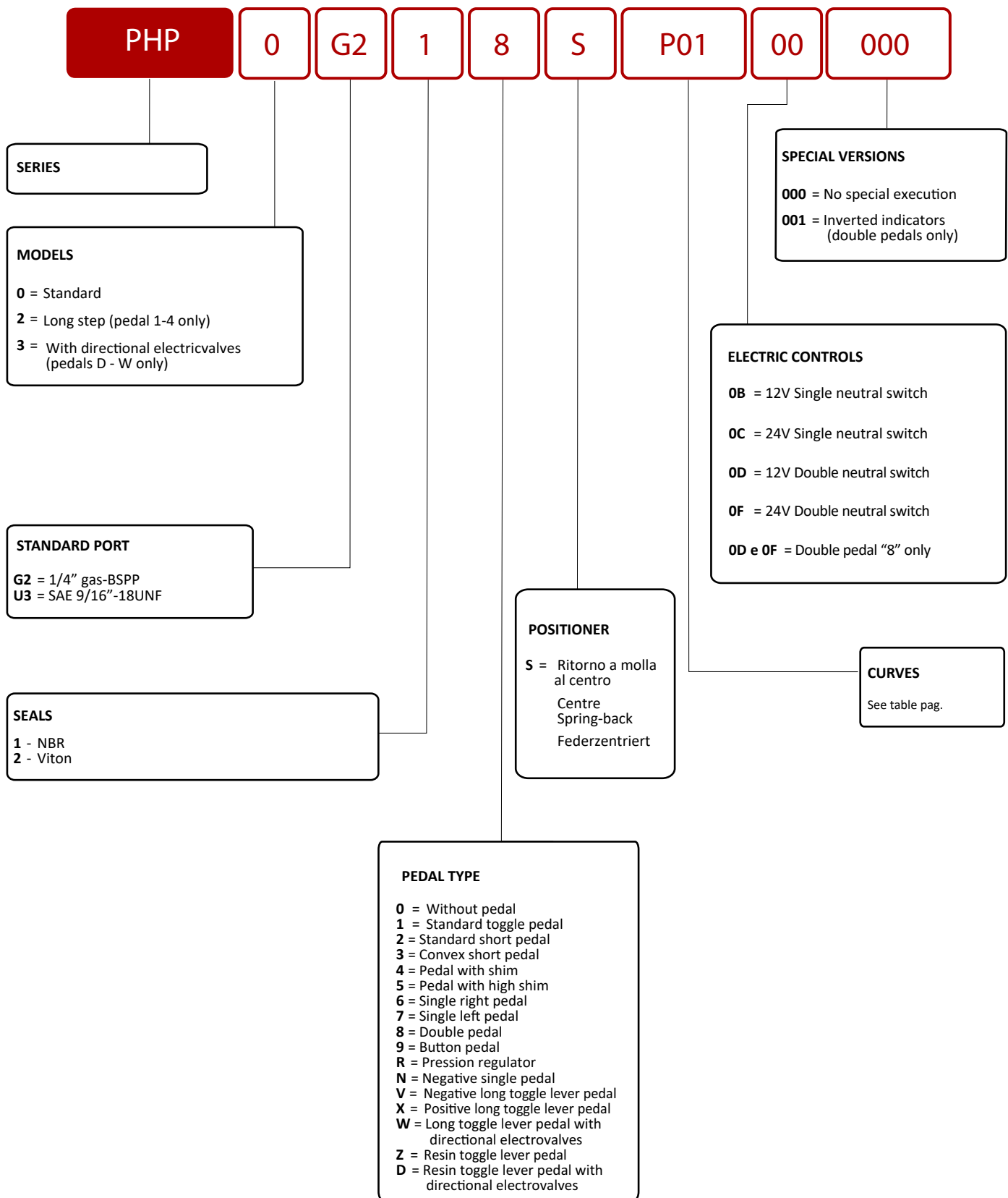

Алматы (7273)495-231  
 Ангарск (3955)60-70-56  
 Архангельск (8182)63-90-72  
 Астрахань (8512)99-46-04  
 Барнаул (3852)73-04-60  
 Белгород (4722)40-23-64  
 Благовещенск (4162)22-76-07  
 Брянск (4832)59-03-52  
 Владивосток (423)249-28-31  
 Владикавказ (8672)28-90-48  
 Владимир (4922)49-43-18  
 Волгоград (844)278-03-48  
 Вологда (8172)26-41-59  
 Воронеж (473)204-51-73  
 Екатеринбург (343)384-55-89

Иваново (4932)77-34-06  
 Ижевск (3412)26-03-58  
 Иркутск (395)279-98-46  
 Казань (843)206-01-48  
 Калининград (4012)72-03-81  
 Калуга (4842)92-23-67  
 Кемерово (3842)65-04-62  
 Киров (8332)68-02-04  
 Коломна (4966)23-41-49  
 Кострома (4942)77-07-48  
 Краснодар (861)203-40-90  
 Красноярск (391)204-63-61  
 Курск (4712)77-13-04  
 Курган (3522)50-90-47  
 Липецк (4742)52-20-81

Магнитогорск (3519)55-03-13  
 Москва (495)268-04-70  
 Мурманск (8152)59-64-93  
 Набережные Челны (8552)20-53-41  
 Нижний Новгород (831)429-08-12  
 Новокузнецк (3843)20-46-81  
 Ноябрьск (3496)41-32-12  
 Новосибирск (383)227-86-73  
 Омск (3812)21-46-40  
 Орел (4862)44-53-42  
 Оренбург (3532)37-68-04  
 Пенза (8412)22-31-16  
 Петрозаводск (8142)55-98-37  
 Псков (8112)59-10-37  
 Пермь (342)205-81-47

Ростов-на-Дону (863)308-18-15  
 Рязань (4912)46-61-64  
 Самара (846)206-03-16  
 Санкт-Петербург (812)309-46-40  
 Саратов (845)249-38-78  
 Севастополь (8692)22-31-93  
 Саянск (8342)22-96-24  
 Симферополь (3652)67-13-56  
 Смоленск (4812)29-41-54  
 Сочи (862)225-72-31  
 Ставрополь (8652)20-65-13  
 Сургут (3462)77-98-35  
 Сыктывкар (8212)25-95-17  
 Тамбов (4752)50-40-97  
 Тверь (4822)63-31-35

Тольятти (8482)63-91-07  
 Томск (3822)98-41-53  
 Тула (4872)33-79-87  
 Тюмень (3452)66-21-18  
 Ульяновск (8422)24-23-59  
 Улан-Удэ (3012)59-97-51  
 Уфа (347)229-48-12  
 Хабаровск (4212)92-98-04  
 Чебоксары (8352)28-53-07  
 Челябинск (351)202-03-61  
 Череповец (8202)49-02-64  
 Чита (3022)38-34-83  
 Якутск (4112)23-90-97  
 Ярославль (4852)69-52-93

Россия +7(495)268-04-70

Казахстан +7(7172)727-132

Киргизия +996(312)96-26-47