

Signal inversion

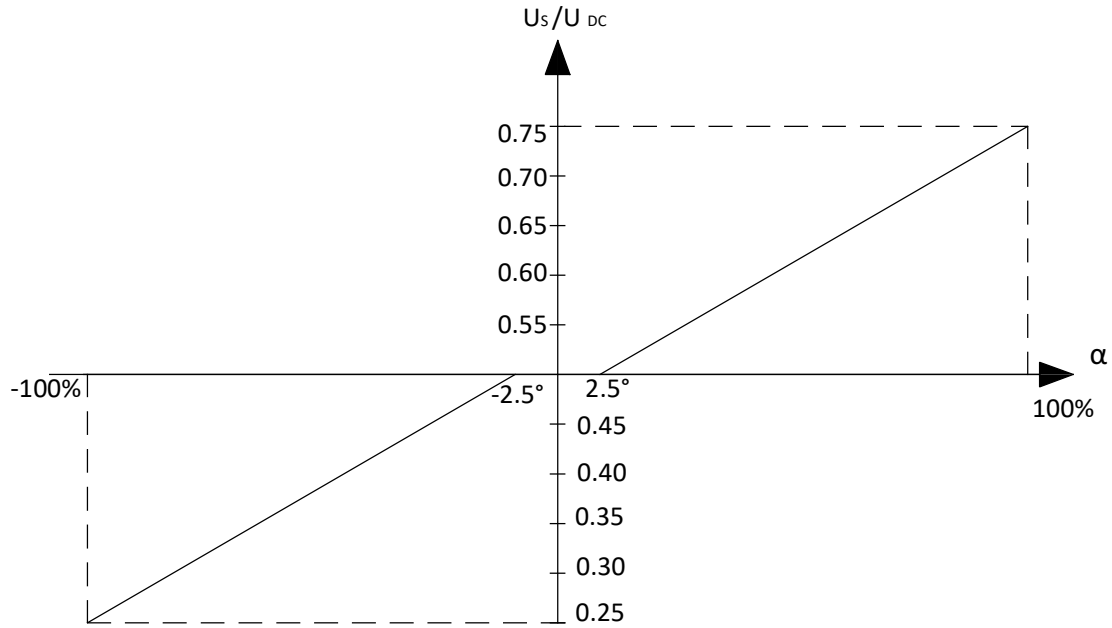

Overall dimensions

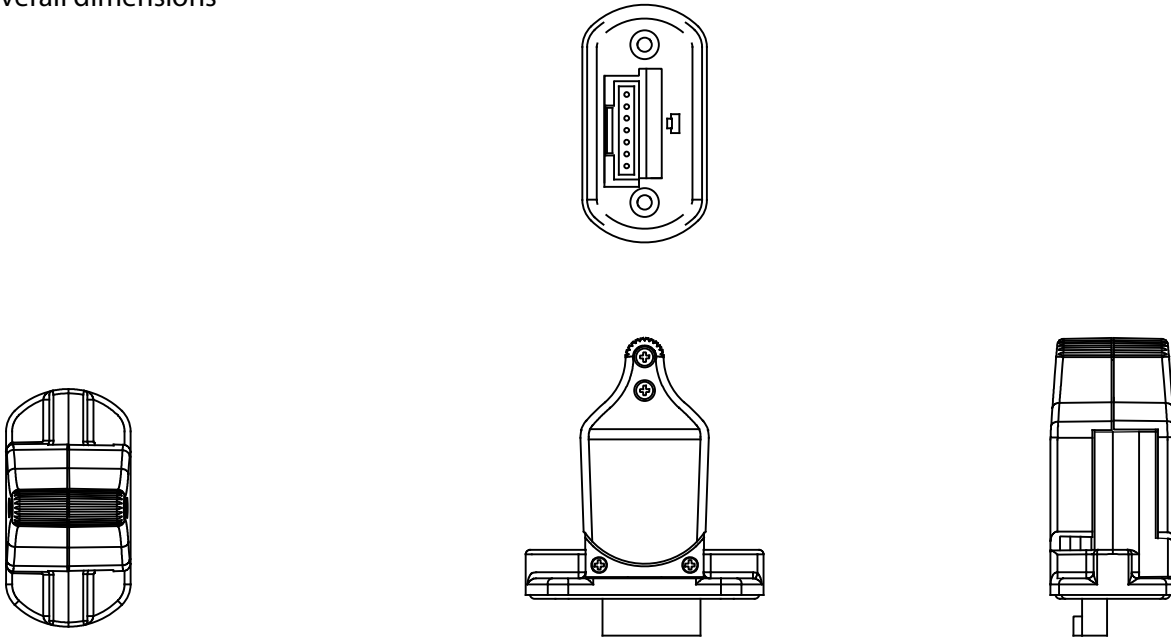

Алматы (7273)495-231  
 Ангарск (3955)60-70-56  
 Архангельск (8182)63-90-72  
 Астрахань (8512)99-46-04  
 Барнаул (3852)73-04-60  
 Белгород (4722)40-23-64  
 Благовещенск (4162)22-76-07  
 Брянск (4832)59-03-52  
 Владивосток (423)249-28-31  
 Владикавказ (8672)26-90-48  
 Владимир (4922)49-43-18  
 Волгоград (844)278-03-48  
 Вологда (8172)26-41-59  
 Воронеж (473)204-51-73  
 Екатеринбург (343)384-55-89

Иваново (4932)77-34-06  
 Ижевск (3412)26-03-58  
 Иркутск (395)279-98-46  
 Казань (843)206-01-48  
 Калининград (4012)72-03-81  
 Калуга (4842)92-23-67  
 Кемерово (3842)65-04-62  
 Киров (8332)68-02-04  
 Коломна (4966)23-41-49  
 Кострома (4942)77-07-48  
 Краснодар (861)203-40-90  
 Красноярск (391)204-63-61  
 Курск (4712)77-13-04  
 Курган (3522)50-90-47  
 Липецк (4742)52-20-81

Магнитогорск (3519)55-03-13  
 Москва (495)268-04-70  
 Мурманск (8152)59-64-93  
 Набережные Челны (8552)20-53-41  
 Нижний Новгород (831)429-08-12  
 Новокузнецк (3843)20-46-81  
 Ноябрьск (3496)41-32-12  
 Новосибирск (383)227-86-73  
 Омск (3812)21-46-40  
 Орел (4862)44-53-42  
 Оренбург (3532)37-68-04  
 Пенза (8412)22-31-16  
 Петрозаводск (8142)55-98-37  
 Псков (8112)59-10-37  
 Пермь (342)205-81-47

Ростов-на-Дону (863)308-18-15  
 Рязань (4912)46-61-64  
 Самара (846)206-03-16  
 Санкт-Петербург (812)309-46-40  
 Саратов (845)249-38-78  
 Севастополь (8692)22-31-93  
 Саранск (8342)22-96-24  
 Симферополь (3652)67-13-56  
 Смоленск (4812)29-41-54  
 Сочи (862)225-72-31  
 Ставрополь (8652)20-65-13  
 Сургут (3462)77-98-35  
 Сыктывкар (8212)25-95-17  
 Тамбов (4752)50-40-97  
 Тверь (4822)63-31-35

Тольятти (8482)63-91-07  
 Томск (3822)98-41-53  
 Тула (4872)33-79-87  
 Тюмень (3452)66-21-18  
 Ульяновск (8422)24-23-59  
 Улан-Удэ (3012)59-97-51  
 Уфа (347)229-48-12  
 Хабаровск (4212)92-98-04  
 Чебоксары (8352)28-53-07  
 Челябинск (351)202-03-61  
 Череповец (8202)49-02-64  
 Чита (3022)38-34-83  
 Якутск (4112)23-90-97  
 Ярославль (4852)69-52-93

Россия +7(495)268-04-70

Казахстан +7(7172)727-132

Киргизия +996(312)96-26-47



HYDRAULIC POWER CONTROL

## PSJF Single axis fingertip joystick with floating lock position function

Mechanical performance		Short handle	Long handle
Breakout force	N	3.1	2.3*
Lever operating force	N	5.1*	3.4*
Maximum allowable force**	N	50*	35*
Lever operating angle	°	± 30	± 30
Expected life (operations)		> 5 milion	> 5 milion
Weight	g	45	45

\* At top of handle

Environmental		
Operating temperature	°C	-20 to +70
Storage temperature	°C	-40 to +85
Environmental protection above the flame		IP65 IEC 60529

Analog track		
Resolution		Virtually infinite
Track resistance (±20%)	KΩ	4 or 5
Track electrical angle	°	± 28
Output voltage range	%	0-100, 10-90, 25-75 of input voltage
Center tap voltage	%	48 - 52 of applied voltage
Center tap angle	°	± 2.5
Supply voltage - maximum	V <sub>DC</sub>	32
Wiper circuit impedance	MΩ	Greater than 0.1**
Power dissipation @ 25°C	W	0.25 (no load)
Insulation resistance		Greater than 50 MΩ at 500Vdc

\*\*\*The long life resistive elements require a high impedance load in the wiper circuit to minimise the current flowing through the wiper for optimum life conditions

Switch directional or center off		
Switch operating angle	°	5 either side of center
Supply voltage - maximum	V <sub>DC</sub>	35
Load resistance - minimum	KΩ	10
Load current - maximum	mA	2 (resistive)
Typical contact resistance	Ω	150

Overall dimensions

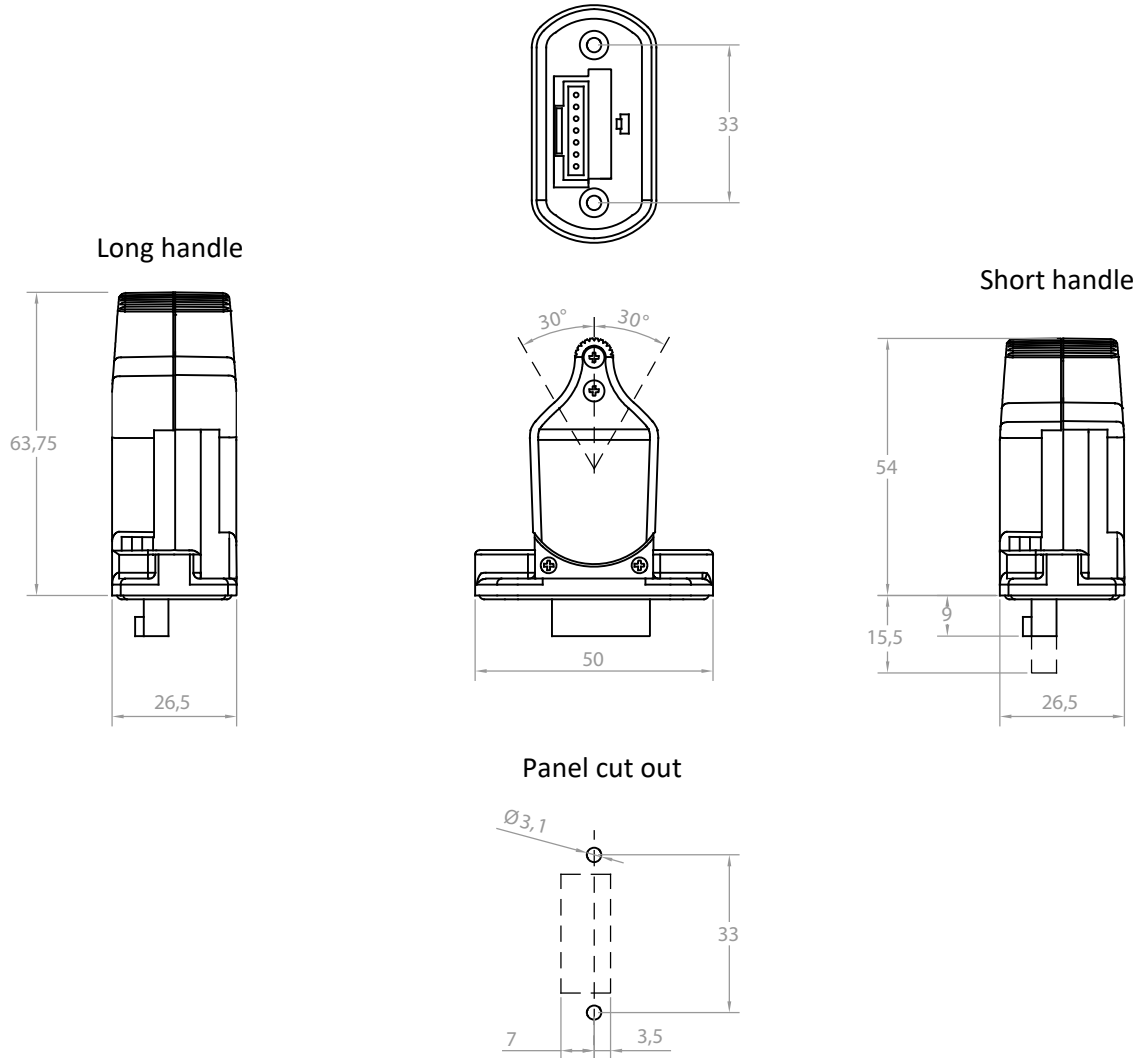

Electrical Connections

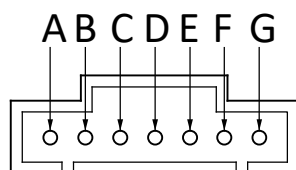

- A = Center Tap
- B = Positive voltage supply
- C = Output voltage signal
- D = Negative or zero voltage supply
- E = N/O switch, lever backward (-Y)
- F = N/O switch, lever forward (+Y)
- G = Common terminal for switches

Mechanical		
Lever action		Self centering (standard) or friction lock (FL option)
Lever breakout force*	N	4.9 to 10.7 (standard)
	N	13 to 17 to overcome detent - FL option
Lever operating force**	N	16.8 to 21.5 (Standard - full lever deflection)
	N	8 to 12 when out of detent - FL option
Maximum allowable force**	N	300
Lever operating angle	°	± 34
Expected life (operations)		Greater than 2 million (0.5 million for Friction Lock (FL) action or handle options CL and EL)
Weight	g	560 without handle fitted

\* Measured at 75mm above upper flange face (80mm for FL option) \*\* Measured at 135mm above upper flange face

Environmental		
Operating temperature	°C	-20 to +70
Storage temperature	°C	-40 to +85
Environmental protection above the flame		IP65 IEC 60529

Analog track		
Resolution		Virtually infinite
Track resistance (±20%)	KΩ	1.6, 2, 2.9, 5, 10
Track electrical angle	°	± 32
Output voltage range	%	0-100, 10-90, 25-75 of input voltage
Center tap voltage	%	48 - 52 of applied voltage
Center tap angle	°	± 2.5
Supply voltage - maximum	V <sub>DC</sub>	35
Wiper circuit impedance	MΩ	1 minimum recommended***
Power dissipation @ 25°C	W	0.25 (no load)
Insulation resistance		Greater than 50 MΩ at 500Vdc

\*\*\*The long life resistive elements require a high impedance load in the wiper circuit to minimise the current flowing through the wiper for optimum life conditions

Switch directional or center off		
Switch operating angle	°	5 or 7.5 either side of center

End Switch		
Switch operating angle	°	28.5 either side of center

Supply voltage - maximum	V <sub>DC</sub>	35
Load current maximum	mA	10 (resistive)

Analog track

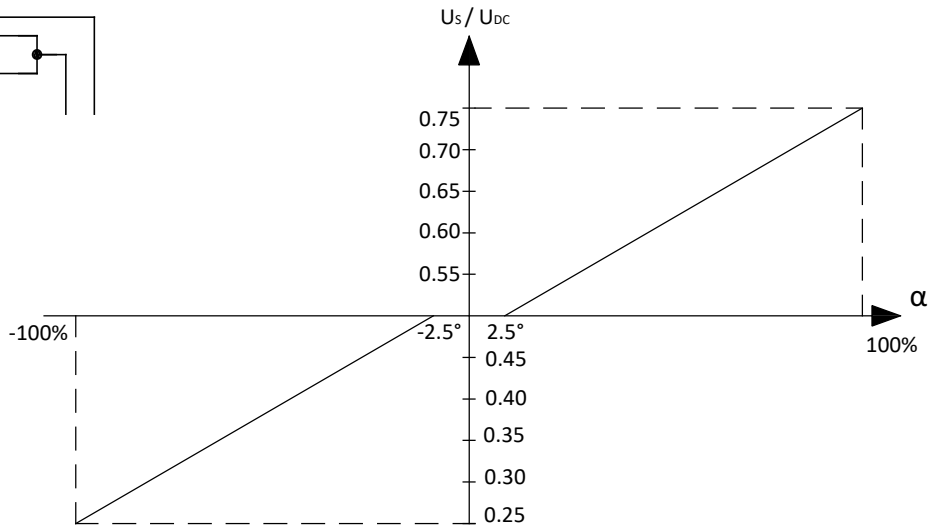
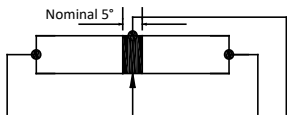

Directional / center off switch

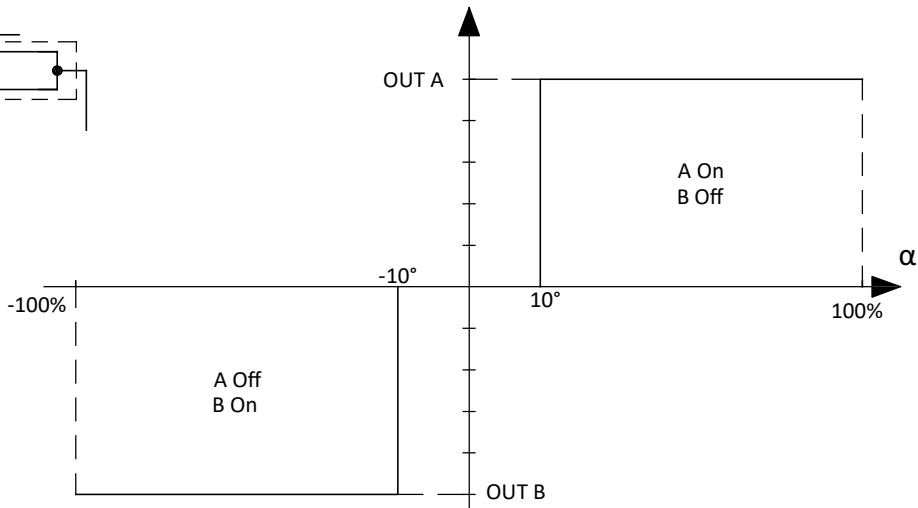
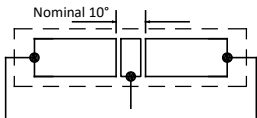

End switch

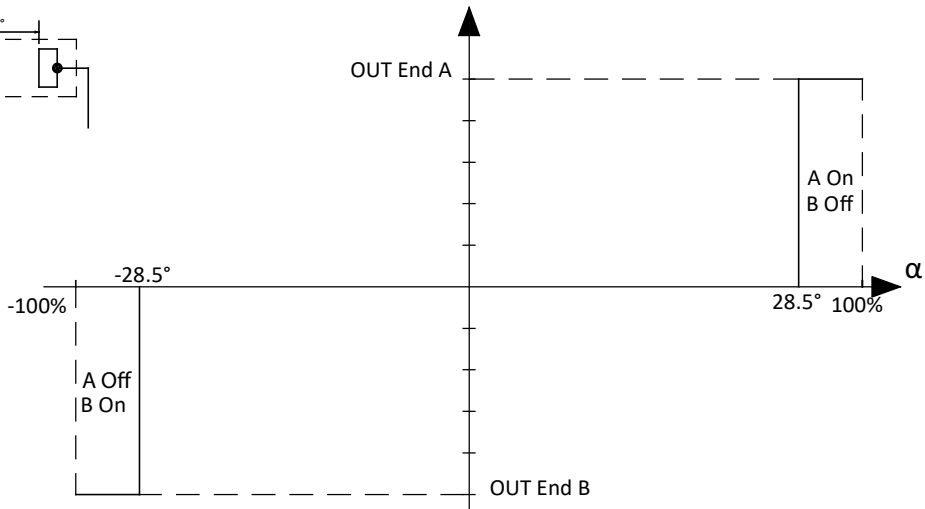
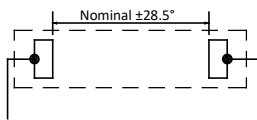

Joystick	Function	Symbol	Description	Code	Weight
	<p>1</p> <p>Proportional bidirectional</p>		Spring centered	PEJS	
			<p>Put &amp; stay (friction lock)</p> <p>The friction lock mechanism offers a braking feature that allows the joystick to come to stop at any point along the joystick axis</p>	PEJS	

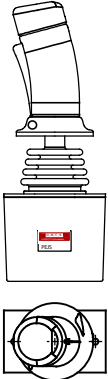
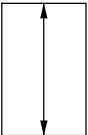
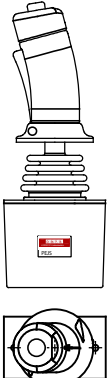
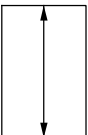
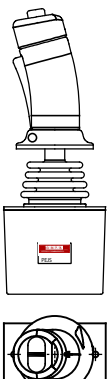
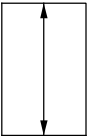
Joystick	Function	Symbol	Description	Code	Weight
	<p>1</p> <p>Proportional bidirectional</p>		<p>Spring centered with person present lever trigger switch</p>	<p>PEJS</p>	
	<p>1</p> <p>Proportional bidirectional</p>		<p>Spring centered with person present lever trigger switch and single top switch</p>	<p>PEJS</p>	
	<p>1</p> <p>Proportional bidirectional</p>		<p>Spring centered with person present lever trigger switch and dual top switch</p>	<p>PEJS</p>	

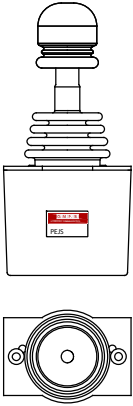
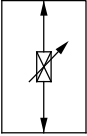
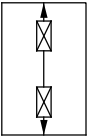
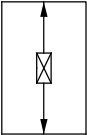
Joystick	Function	Symbol	Description	Code	Weight
	<p>1</p> <p>Proportional bidirectional</p>		<p><b>Put &amp; stay with neutral position lock</b></p> <p>The joystick is fitted with neutral lock that prevent the joystick from begin unintentionally operated. The mechanism can be released by lifting the release ring at the base of the hendle. Beside of this, the friction lock offers a braking feature that allows the joystick to come to stop at any point along the joystick axis.</p>	PEJS	
			<p><b>Spring centred with full end travel position lock</b></p> <p>The joystick is fitted with an end travel position lock, such that, if the joystick is operated to full travel in either direction, the handle will lock at this position and not return to centre. The lock mechanism is released by lifting the collar at the base of the handle, and the joystick will return to neutral position.</p>	PEJS	
			<p><b>Put &amp; stay with neutral position lock</b></p> <p>The joystick is fitted with neutral lock that prevent the joystick from being unintentionally operated. The mechanism can be released by lifting the release ring at the base of the hendle. Besides of this, the friction lock offers a braking feature that allows the joystick to come to stop at any point along the joystick axis.</p>		



## Signal inversion

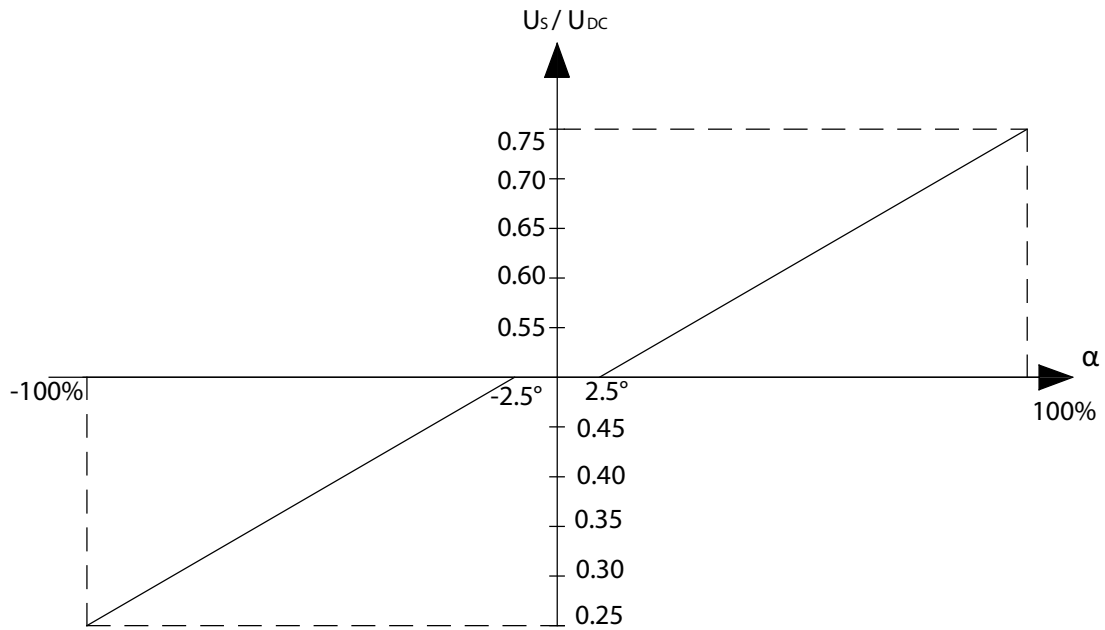

## Overall dimensions

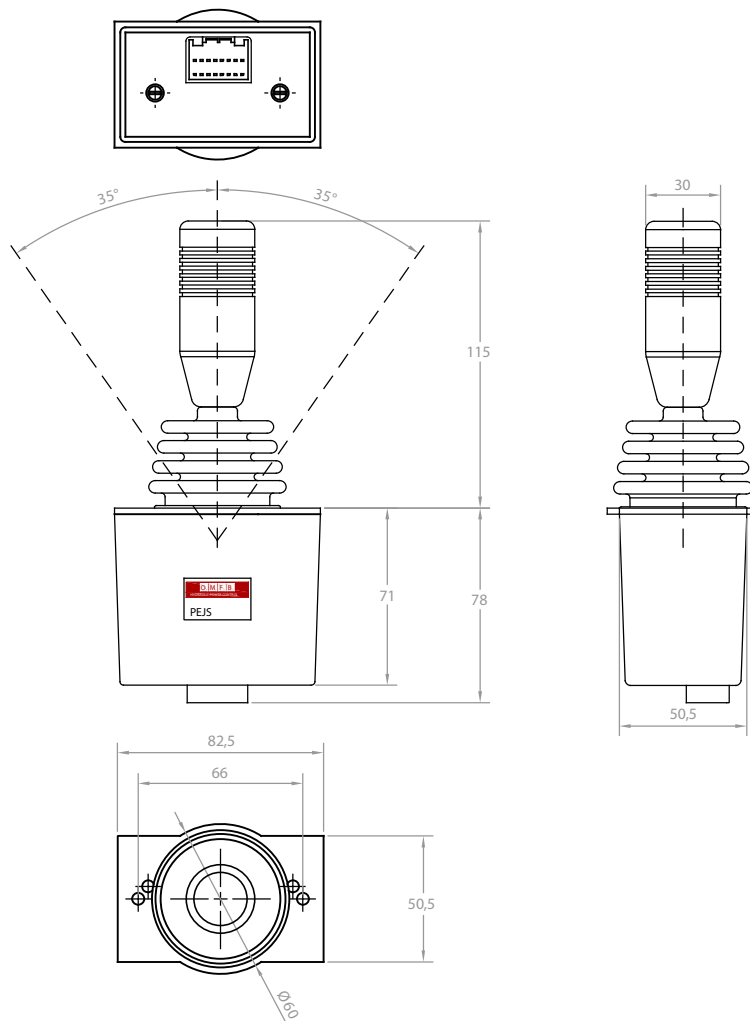

Signal inversion

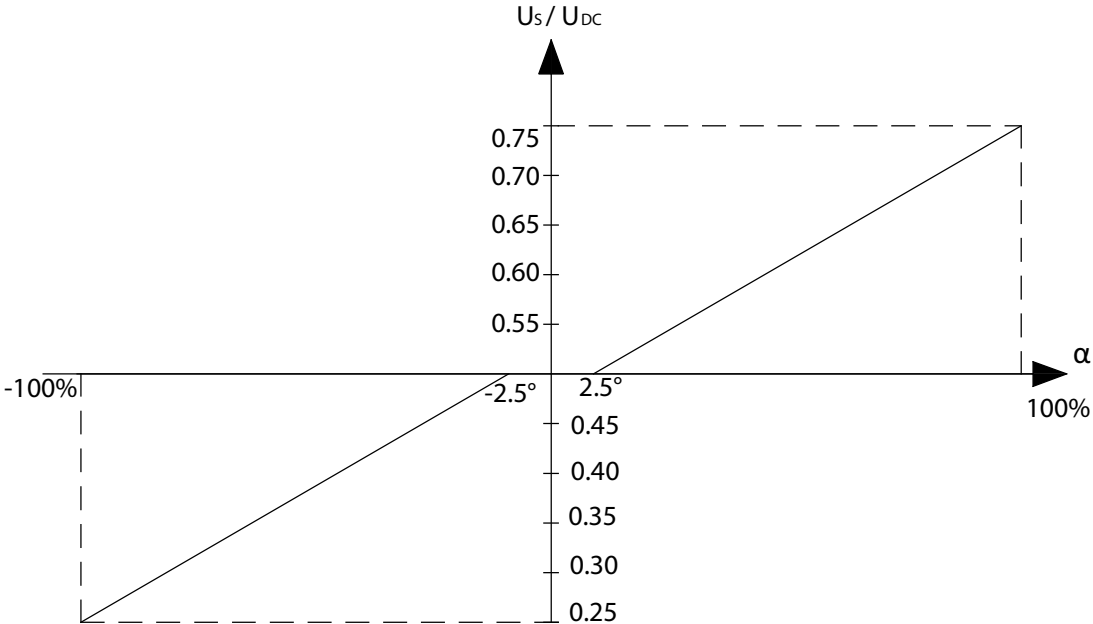

Overall dimensions

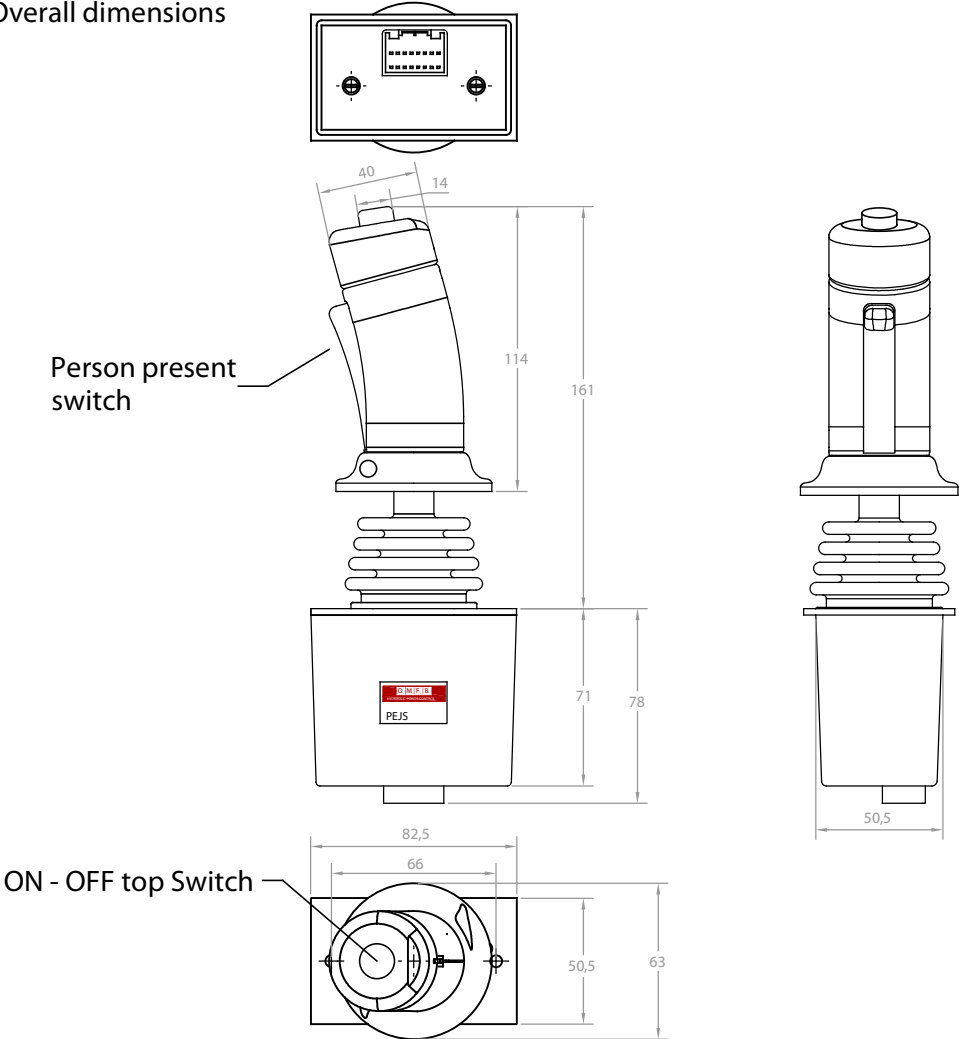

Signal inversion

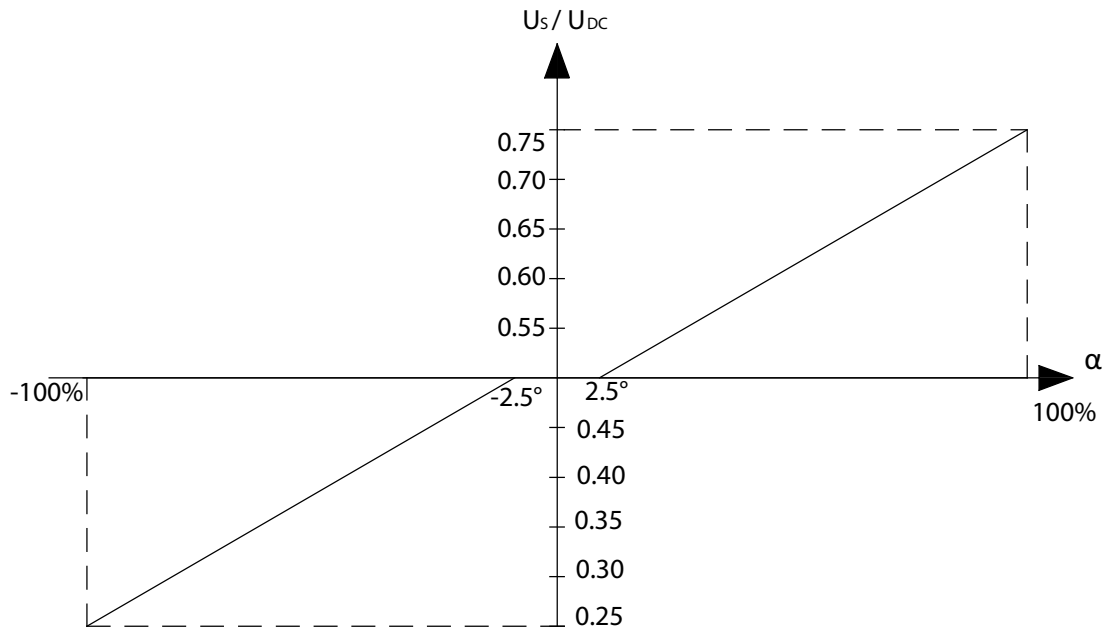

Overall dimensions

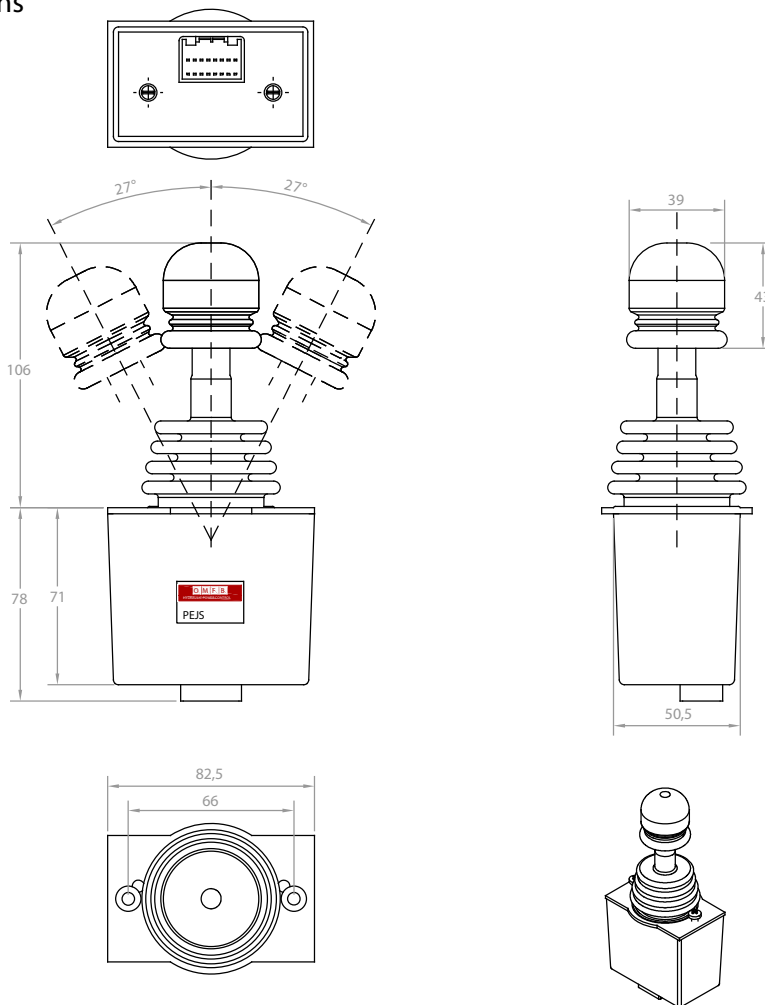

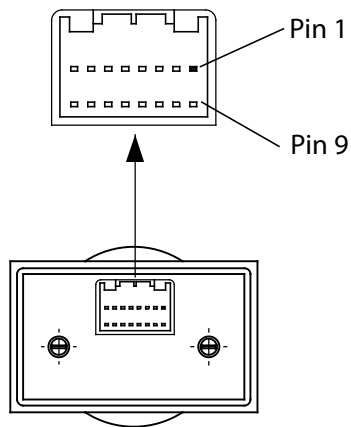
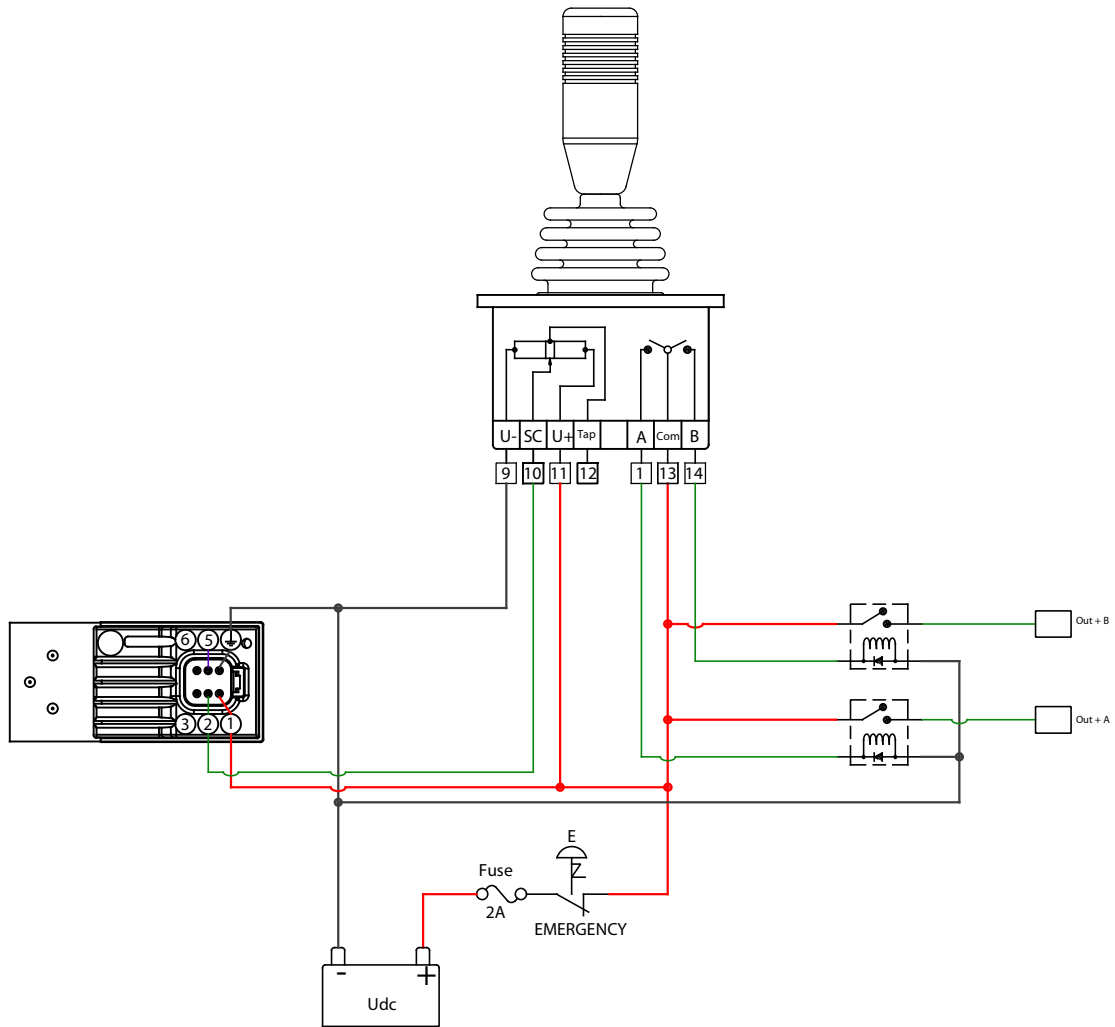

- 1 = Directional switch track N/O signal (lever backward -Y)
- 2 = End switch track N/O signal (lever fully backward -Y) \*
- 3 = Not used
- 4 = Not used
- 5 = Not used
- 6 = Not used
- 7 = Not used
- 8 = Not used
- 9 = Negative or zero voltage supply
- 10 = Output voltage signal
- 11 = Positive voltage supply
- 12 = Center tap
- 13 = Common terminal for directional switches
- 14 = Directional switch track N/O signal (lever forward +Y)
- 15 = End switch track N/O signal (lever fully forward +Y) \*
- 16 = Common terminal for handle switches

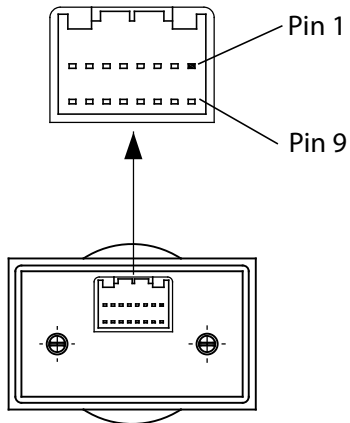
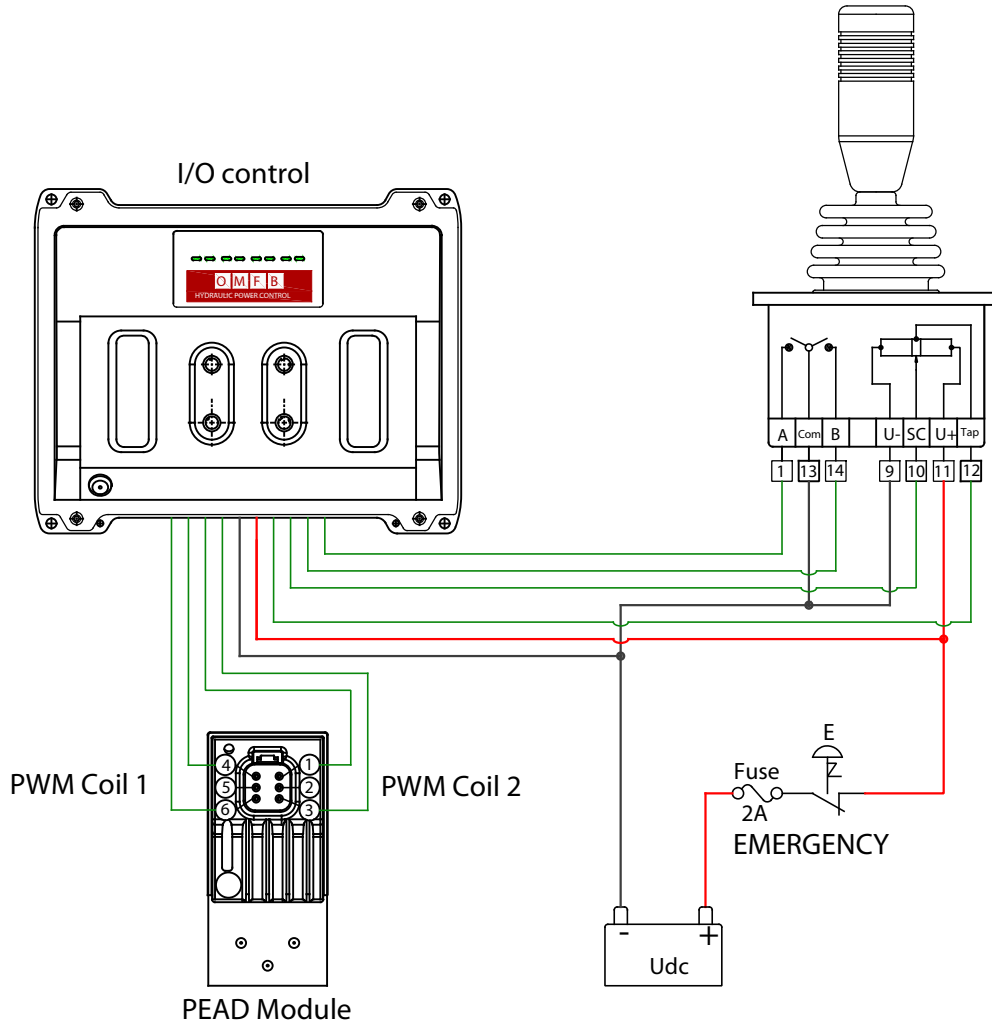

- 1 = Directional switch track N/O signal (lever backward -Y)
- 2 = End switch track N/O signal (lever fully backward -Y) \*
- 3 = Not used
- 4 = Not used
- 5 = Not used
- 6 = Not used
- 7 = Not used
- 8 = Not used
- 9 = Negative or zero voltage supply
- 10 = Output voltage signal
- 11 = Positive voltage supply
- 12 = Center tap
- 13 = Common terminal for directional switches
- 14 = Directional switch track N/O signal (lever forward +Y)
- 15 = End switch track N/O signal (lever fully forward +Y) \*
- 16 = Common terminal for handle switches

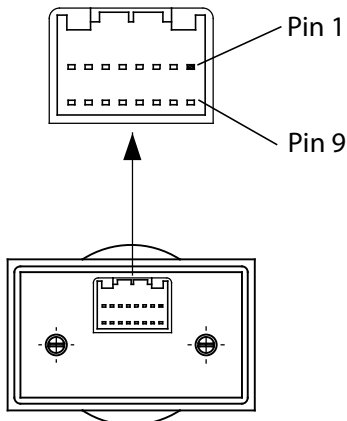
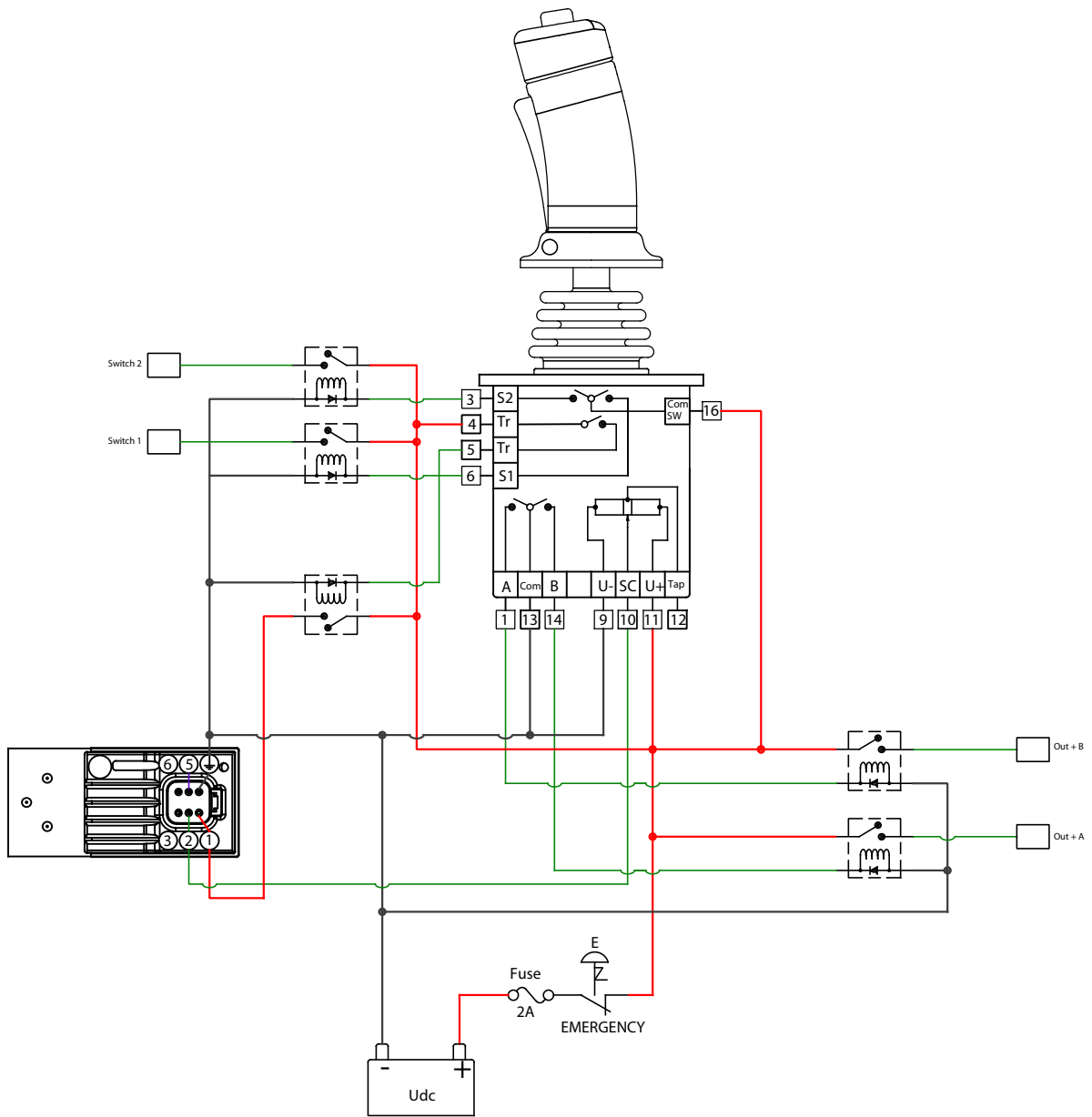

- 1 = Directional switch track N/O signal (lever backward -Y)
- 2 = End switch track N/O signal (lever fully backward -Y) \*
- 3 = Handle switch 2
- 4 = Trigger switch
- 5 = Trigger switch
- 6 = Handle switch 1
- 7 = Not used
- 8 = Not used
- 9 = Negative or zero voltage supply
- 10 = Output voltage signal
- 11 = Positive voltage supply
- 12 = Center tap
- 13 = Common terminal for directional switches
- 14 = Directional switch track N/O signal (lever forward +Y)
- 15 = End switch track N/O signal (lever fully forward +Y) \*
- 16 = Common terminal for handle switches

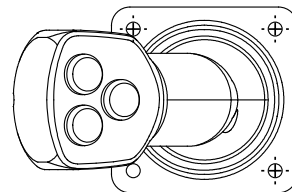
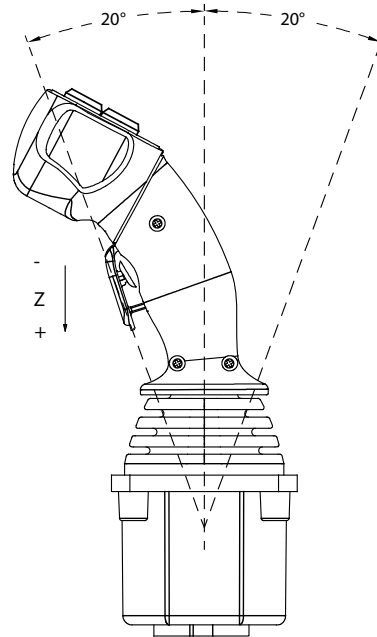
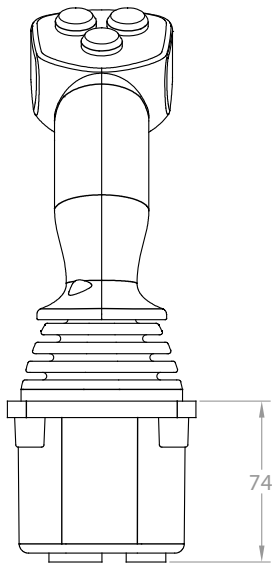
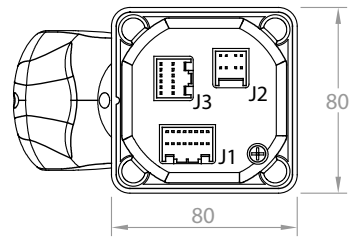

### Output characteristics

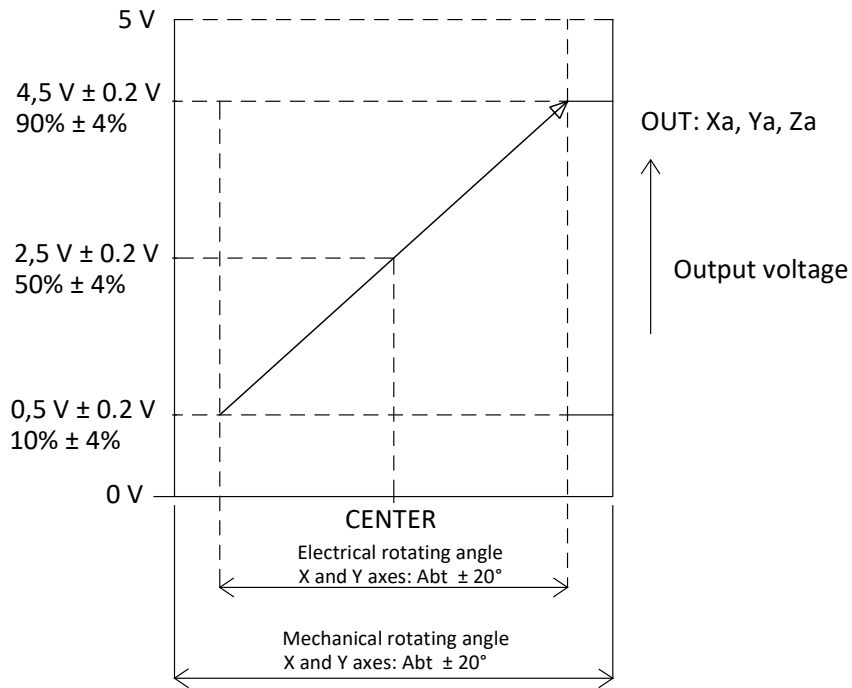

Each axes ⊖ direction ← | → Each axes ⊕ direction

**J1 Connector - 16 Pins**

Pin	Function (potentiometer)
1	Y switch track N/O (lever forward +Y)
2	X switch track center on
3	X pot track left
4	X pot track wiper signal
5	X pot track right
6	X pot track center tap
7	X switch track common
8	X switch track N/O (lever left -X)
9	Y pot track backward
10	Y pot track wiper signal
11	Y pot track forward
12	Y pot track center tap
13	Y switch track common
14	Y switch track N/O (lever backward -Y)
15	X switch track N/O (lever right +X)
16	Y switch track center on



Overall dimensions

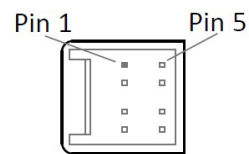
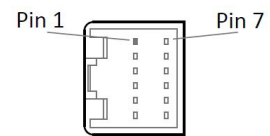
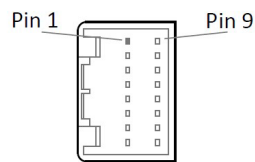
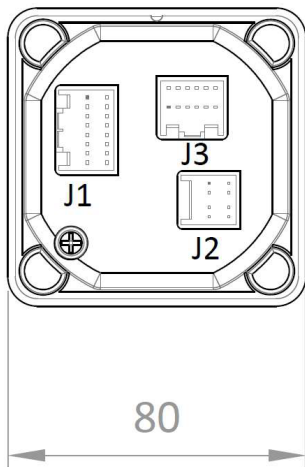
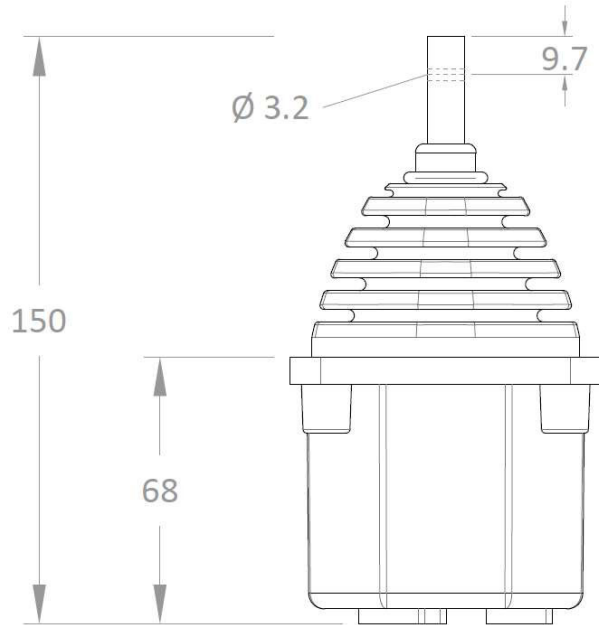

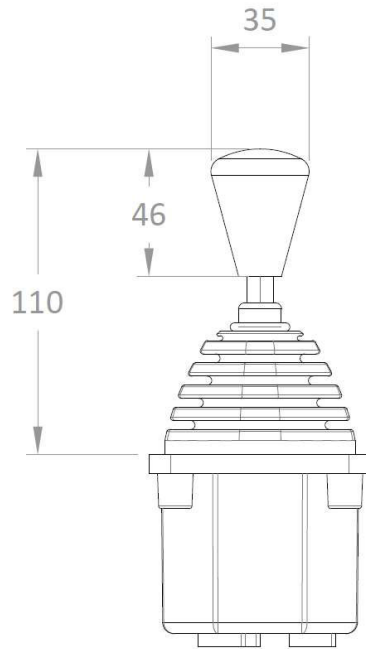
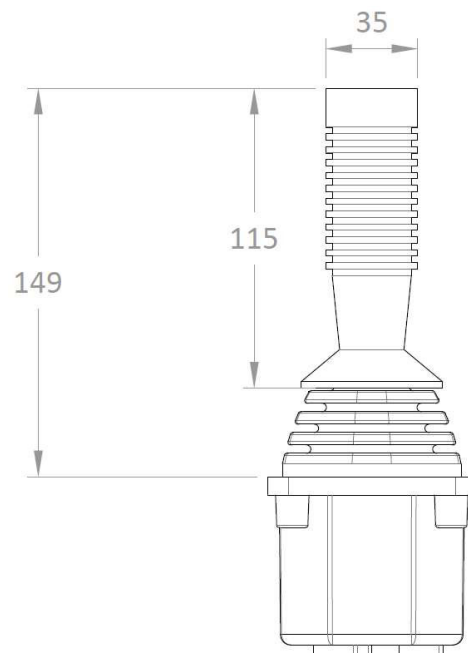
**Handle options:****HKH MECHANICAL DIMENSIONS****HB MECHANICAL DIMENSIONS**

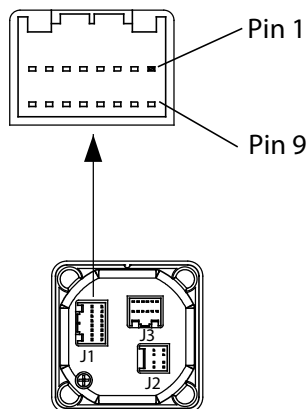
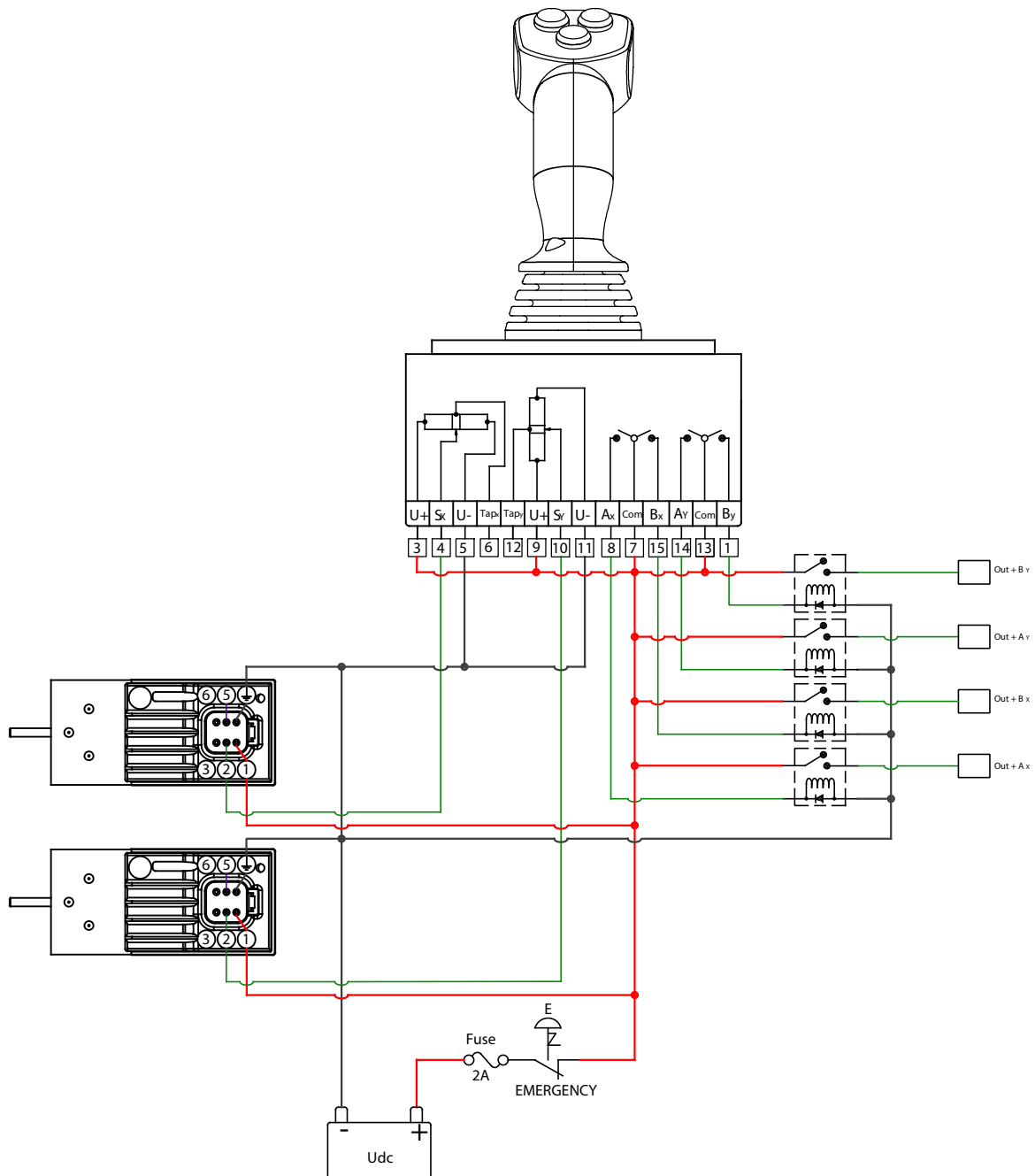

- 1 = Directional switch track N/O signal (lever backward -Y)
- 2 = X switch track center on
- 3 = X pot track left
- 4 = X pot track wiper signal
- 5 = X pot track right
- 6 = X pot track center tap
- 7 = X switch track common
- 8 = X switch track N/O (lever left -X)
- 9 = Y pot track backward
- 10 = Y pot track wiper signal
- 11 = Y pot track forward
- 12 = Y pot track center tap
- 13 = Y switch track common
- 14 = Y switch track N/O signal (lever backward -Y)
- 15 = X switch track N/O signal (lever right +X) \*
- 16 = Y switch track center on

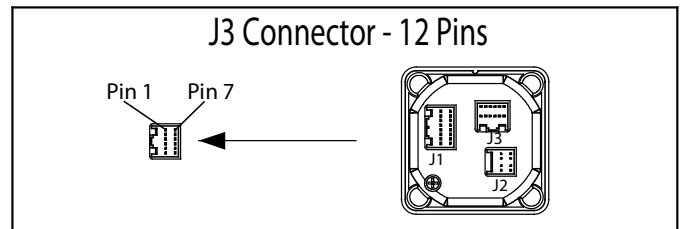
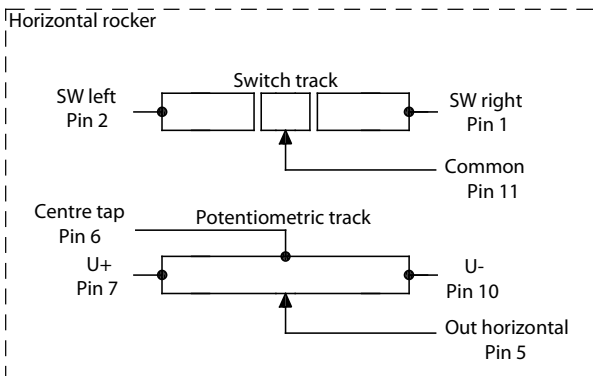
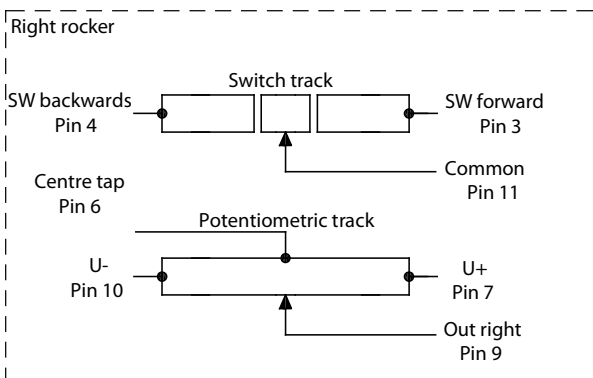
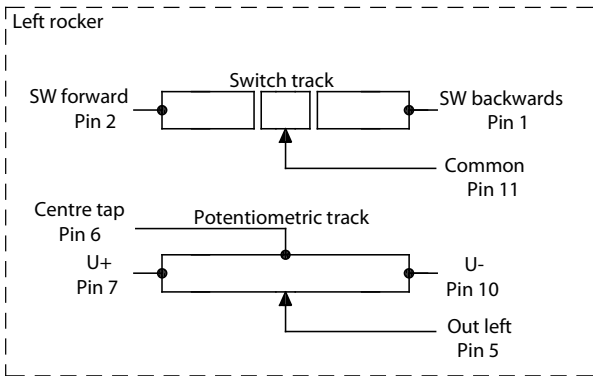

Pin	Function (Rockers)	Wire color
1	Left switch backward	Green
2	Left switch forward or horizontal left	Blue / Orange
3	Right switch forward	Yellow
4	Right switch backward	Blue
5	Left output or horizontal output signal	Pink
6	Rockets center tap	Yellow / Red
7	Rockets positive power supply U+	White / Red
8	Person present switch	Black / White
9	Right output signal	White
10	Rockets negative power supply U-	Pink / Grey
11	Rockets switch common	Black
12	Person present switch	Red / Green

Faceplate options

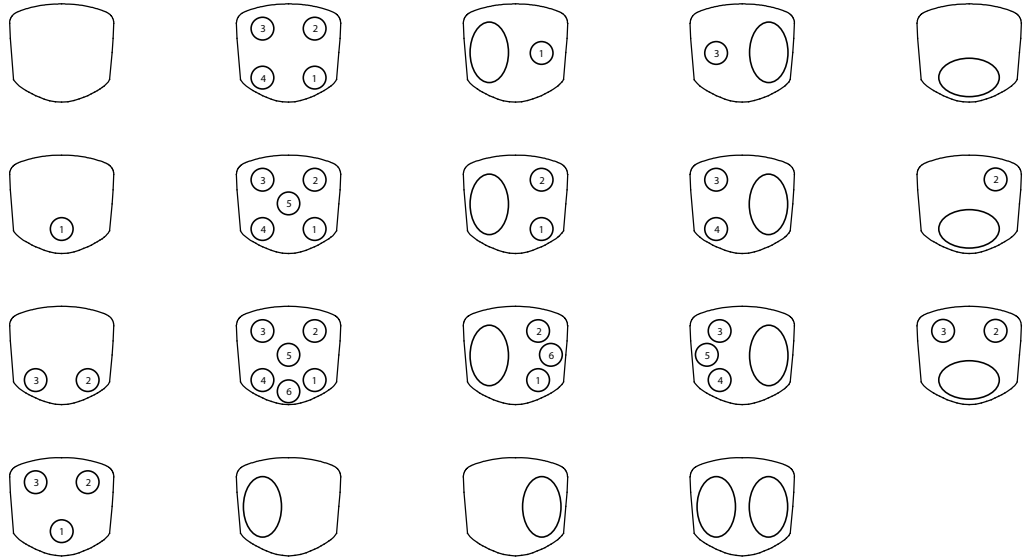
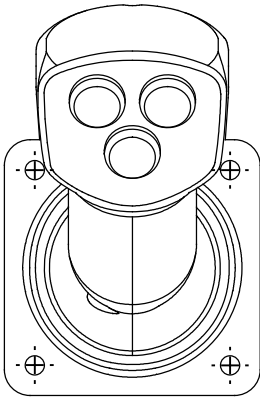

J3 Connector - 12 Pins

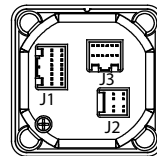
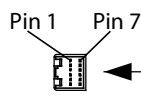

Pin	Function (Switches)	Wire color
1	Switch 4	White / Green
2	Switch 3	Blue / White
3	Switch 2	Yellow
4	Switch 1	Blue
5	Switch 5	Red
6	-	Yellow / Red
7	-	White / Red
8	Person present switch	Black / White
9	Switch 6	Violet
10	-	Pink / Grey
11	Common terminal for all switches	Black
12	Person present switch	Red / Green

<b>PERFORMANCE</b>		
<b>MECHANICAL</b>		
Lever operating force		
breakout*	N	7 or 16
operating*	N	19 or 39 (full deflection)
maximum allowable**	N	390 (490 overload)
Lever mechanical angle		
single axis only	°	±20 forward/reverse
square gate	°	±20 in X and Y directions
Seat		preferred bias on axis
Expected life		15 million operations (5 million for potentiometer track version)
Weight	g	750 without handle fitted
* Measured at 55mm above upper flange face		** Measured 130mm above upper flange face
<b>ENVIRONMENTAL</b>		
Operating temperature	°C	-25 to +80 (-25 to +80 with microswitches)
Storage temperature	°C	-25 to +85 (-25 to +85 with microswitches)
Environmental protection(above the flange) (above the flange)		IP66 IEC 60529 (fitted with HKN handle)
Vibration		Level ±3g,10Hz to 200Hz (random) @ 3.6g(rms)
Shock		20g, 6mS, half sine profile
EMC immunity level		100V/m, 30MHz to 1GHz, 1KHz 80% sine wave modulation, EN50082-2 (1995)
EMC emissions level		Complies with EN50081-2 (1993), 150kHz to 30MHz, level B
ESD immunity level		IEC61000-4-2 level 4 8kV contact discharge, 15kV air discharge
<b>ELECTRICAL – HALL EFFECT SENSOR</b>		
Resolution		Infinite
Supply voltage range	Vdc	5 ± 0.5 regulated transient free
Over voltage (maximum)	Vdc	15 continuous
Reverse polarity (maximum)	Vdc	14.5
Output voltage span - options	Vdc	±25% span - nominal 1.1 to 3.9
		±30% span - nominal 1.0 to 4.0
		±40% span - nominal 0.5 to 4.5
Load impedance (minimum)	kΩ	5
Center voltage (no load)	%	48 - 52 of supply voltage
Current consumption	mA	13 per axis (6.5 per sensor)
Insulation resistance		Greater than 50MΩ at 50Vdc
Output sense		The dual outputs rise together in the same direction, increasing with lever forward (and right), decreasing with lever backward (and left)
Output matching		See maximum output difference diagram below
<b>ELECTRICAL CONNECTIONS</b>		
Mating 12 way connector and pins		SA48061 (AMP 040 12 way connector 174045-2; pins 175062-1)
Mating 12 way harness		P49779 (connector, pins and 380mm long cable)

<b>ELECTRICAL – POTENTIOMETER TRACK</b>		
Resolution		Virtually infinite
Track resistance $\hat{A}\pm 20\%$	K $\Omega$	1.8, 2, 2.9, 5
Track operating angle	$^{\circ}$	$\pm 18$
Output voltage range	%	0-100, 10-90, 25-75 of input
Center tap voltage	%	48 - 52 of applied voltage
Center tap angle	$^{\circ}$	$\pm 2.5$
Center tap to switch alignment	$^{\circ}$	Within 0.5
Supply voltage maximum	Vdc	32
Wiper circuit impedance	M $\Omega$	1 minimum recommended*
Power dissipation @ 25°C	W	0.25
Insulation resistance		Greater than 15M $\hat{I}$ @ 50Vdc
* The long life resistive elements require a high impedance load in the wiper circuit to minimise the current flowing through the wiper for optimum life conditions		
<b>ELECTRICAL – DIRECTIONAL OR CENTER SWITCH (LOW CURRENT)</b>		
		Not available with CANbus output
Switch operating angle	$^{\circ}$	1.5 or 5 either side of center
Supply voltage maximum	Vdc	35
Load current maximum	mA	200 resistive
<b>ELECTRICAL CONNECTIONS</b>		
All primary potentiometer track and directional/center switch connections terminate in a 16-way AMP 040 series multi-lock connector in the joystick base. Secondary potentiometer track connections terminate in an 8-way AMP 040 series multi-lock connector.		
Mating 16 way connector and pins		SA47931 (AMP 040 16 way connector 174046-2; Pins 175062-1)
Mating 16 way harness		P49780 (connector, pins and 380mm long cable)
Mating 8 way connector and pins		SA304522 (AMP 040 8 way connector 174044-2; pins 175062-1)
Mating 8 way harness		P303083 (connector, pins and 380mm long cable)
<b>ELECTRICAL MICROSWITCH</b>		
		Not available with CANbus output
Switch configuration		Two switches per axis Normally open at lever center position
Switch operating angle	$^{\circ}$	. 2 to 5 either side of
Contact rating		center 3A @125Vac, 2A @ 30Vdc
Switch life minimum		100,000 cycles, cycled at 1Hz, 1A and 12Vdc
Operating temperature	$^{\circ}\text{C}$	-25 to +85
<b>ELECTRICAL CONNECTIONS</b>		
Microswitch connections in the potentiometer joystick will replace the low current directional/center switches in the 16-way AMP 040 series multi-lock connector in the joystick base. In the Hall sensor joystick, switches terminate in the 8-way connector.		
<b>CAN OUTPUT VERSION</b>		
JC6000 with Hall sensing option can also be supplied with an integrated CANBUS output offering the J1939 protocol. This CANBUS interface meets the requirements of IEC61508 SIL level 1		
Supply voltage range	Vdc	9 to 36
CAN version		CAN 2.0b
Protocol		J1939
Under-panel sealing		IP66 IEC60529
<b>ELECTRICAL CONNECTIONS</b>		
Mating connector and pins		All connections terminate in the 6-way Deutsch DTM04-6P integrated connector P304844 (includes 390mm flying leads)

**PEJD** double axis proportional joystick  
code number: **PEJD40020D0**

with person present switch and two on-off push button switch

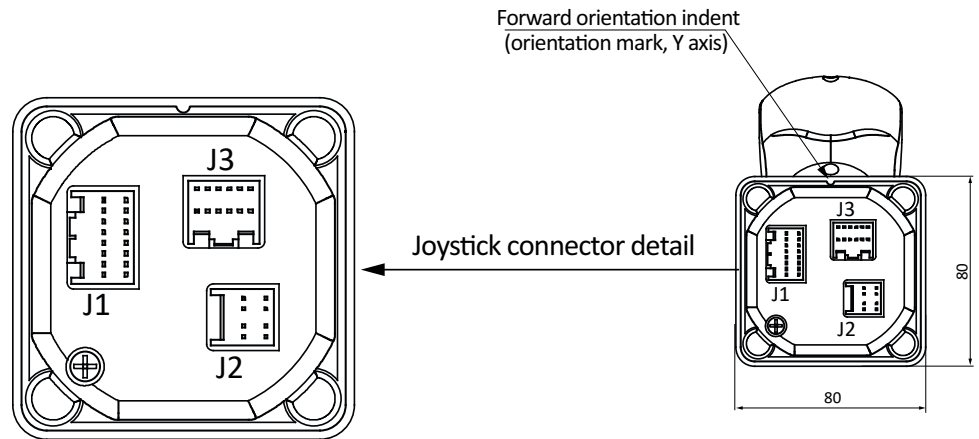

2 Buttons

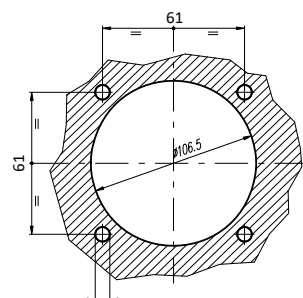
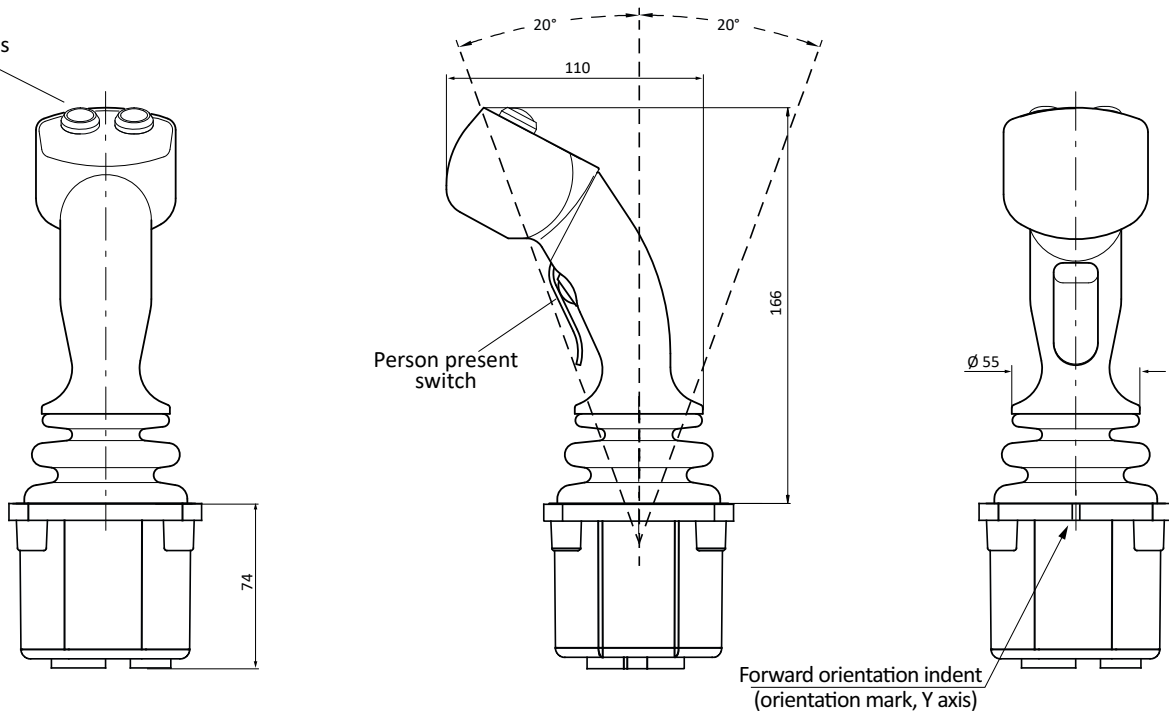

Panel mounting details

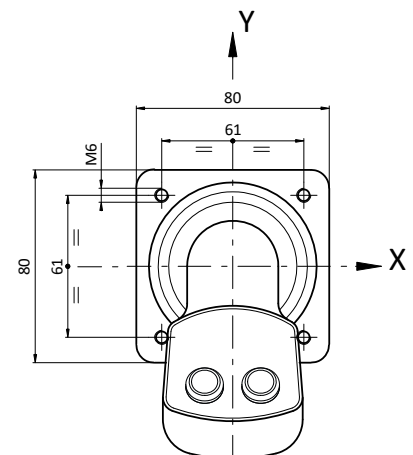



Output characteristics

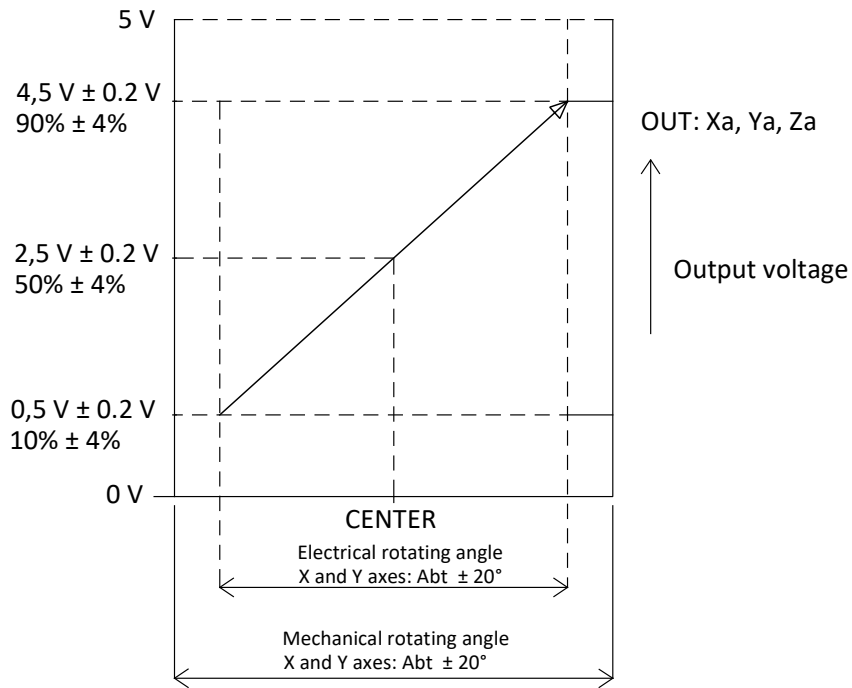

Each axes  $\ominus$  direction  $\leftarrow$   $\rightarrow$  Each axes  $\oplus$  direction

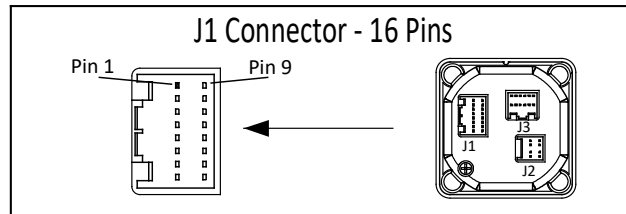

Pin	Function (potentiometer)
1	Y switch track N/O (lever forward +Y)
2	X switch track center on
3	X pot track left
4	X pot track wiper signal
5	X pot track right
6	X pot track center tap
7	X switch track common
8	X switch track N/O (lever left -X)
9	Y pot track backward
10	Y pot track wiper signal
11	Y pot track forward
12	Y pot track center tap
13	Y switch track common
14	Y switch track N/O (lever backward -Y)
15	X switch track N/O (lever right +X)
16	Y switch track center on

Faceplate options

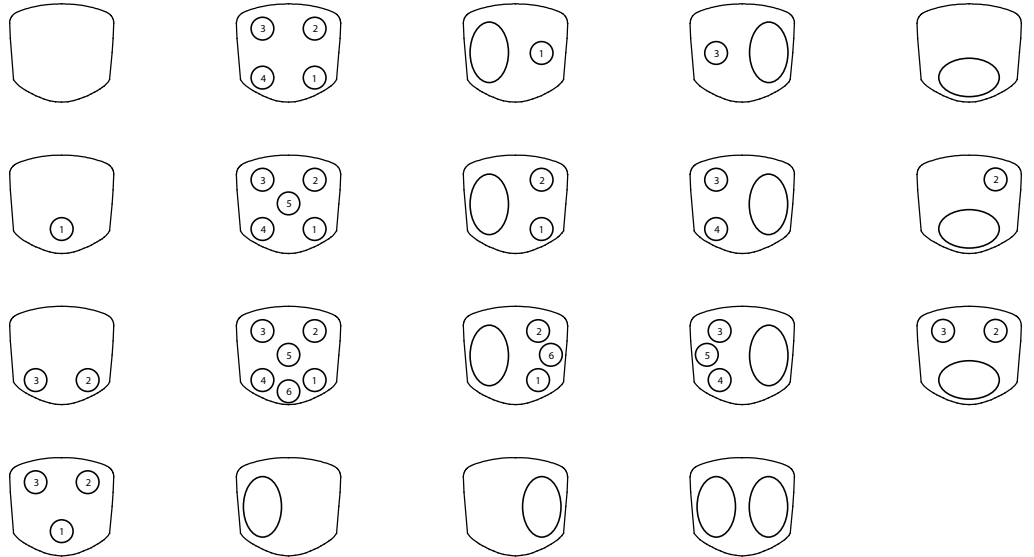
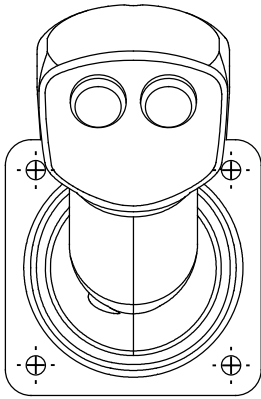

J3 Connector - 12 Pins

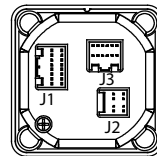
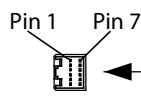

Pin	Function (Switches)	Wire color
1	Switch 4	White / Green
2	Switch 3	Blue / White
3	Switch 2	Yellow
4	Switch 1	Blue
5	Switch 5	Red
6	-	Yellow / Red
7	-	White / Red
8	Person present switch	Black / White
9	Switch 6	Violet
10	-	Pink / Grey
11	Common terminal for all switches	Black
12	Person present switch	Red / Green



HYDRAULIC POWER CONTROL

**PEJD** double axis proportional joystick  
code number: **PEJD40020D0**

with person present switch and two on-off push button switch

PERFORMANCE		
<b>MECHANICAL</b>		
Lever operating force		
breakout*	N	7 or 16
operating*	N	19 or 39 (full deflection)
maximum allowable**	N	390 (490 overload)
Lever mechanical angle		
single axis only	°	±20 forward/reverse
square gate	°	±20 in X and Y directions
Seat		preferred bias on axis
Expected life		15 million operations (5 million for potentiometer track version)
Weight	g	750 without handle fitted
* Measured at 55mm above upper flange face		** Measured 130mm above upper flange face
<b>ENVIRONMENTAL</b>		
Operating temperature	°C	-25 to +80 (-25 to +80 with microswitches)
Storage temperature	°C	-25 to +85 (-25 to +85 with microswitches)
Environmental protection(above the flange) (above the flange)		IP66 IEC 60529 (fitted with HKN handle)
Vibration		Level ±3g,10Hz to 200Hz (random) @ 3.6g(rms)
Shock		20g, 6mS, half sine profile
EMC immunity level		100V/m, 30MHz to 1GHz, 1KHz 80% sine wave modulation, EN50082-2 (1995)
EMC emissions level		Complies with EN50081-2 (1993), 150kHz to 30MHz, level B
ESD immunity level		IEC61000-4-2 level 4 8kV contact discharge, 15kV air discharge
<b>ELECTRICAL – HALL EFFECT SENSOR</b>		
Resolution		Infinite
Supply voltage range	Vdc	5 ± 0.5 regulated transient free
Over voltage (maximum)	Vdc	15 continuous
Reverse polarity (maximum)	Vdc	14.5
Output voltage span - options	Vdc	±25% span - nominal 1.1 to 3.9
		±30% span - nominal 1.0 to 4.0
		±40% span - nominal 0.5 to 4.5
Load impedance (minimum)	kΩ	5
Center voltage (no load)	%	48 - 52 of supply voltage
Current consumption	mA	13 per axis (6.5 per sensor)
Insulation resistance		Greater than 50MΩ at 50Vdc
Output sense		The dual outputs rise together in the same direction, increasing with lever forward (and right), decreasing with lever backward (and left)
Output matching		See maximum output difference diagram below
<b>ELECTRICAL CONNECTIONS</b>		
Mating 12 way connector and pins		SA48061 (AMP 040 12 way connector 174045-2; pins 175062-1)
Mating 12 way harness		P49779 (connector, pins and 380mm long cable)



HYDRAULIC POWER CONTROL

**PEJD** double axis proportional joystick  
code number: **PEJD40020D0**

with person present switch and two on-off push button switch

<b>ELECTRICAL – POTENTIOMETER TRACK</b>		
Resolution		Virtually infinite
Track resistance $\hat{A}\pm 20\%$	K $\Omega$	1.8, 2, 2.9, 5
Track operating angle	°	$\pm 18$
Output voltage range	%	0-100, 10-90, 25-75 of input
Center tap voltage	%	48 - 52 of applied voltage
Center tap angle	°	$\pm 2.5$
Center tap to switch alignment	°	Within 0.5
Supply voltage maximum	Vdc	32
Wiper circuit impedance	M $\Omega$	1 minimum recommended*
Power dissipation @ 25°C	W	0.25
Insulation resistance		Greater than 15M $\Omega$ at 50Vdc
* The long life resistive elements require a high impedance load in the wiper circuit to minimise the current flowing through the wiper for optimum life conditions		
<b>ELECTRICAL – DIRECTIONAL OR CENTER SWITCH (LOW CURRENT)</b>		Not available with CANbus output
Switch operating angle	°	1.5 or 5 either side of center
Supply voltage maximum	Vdc	35
Load current maximum	mA	200 resistive
<b>ELECTRICAL CONNECTIONS</b> All primary potentiometer track and directional/center switch connections terminate in a 16-way AMP 040 series multi-lock connector in the joystick base. Secondary potentiometer track connections terminate in an 8-way AMP 040 series multi-lock connector.		
Mating 16 way connector and pins		SA47931 (AMP 040 16 way connector 174046-2; Pins 175062-1)
Mating 16 way harness		P49780 (connector, pins and 380mm long cable)
Mating 8 way connector and pins		SA304522 (AMP 040 8 way connector 174044-2; pins 175062-1)
Mating 8 way harness		P303083 (connector, pins and 380mm long cable)
<b>ELECTRICAL MICROSWITCH</b>		Not available with CANbus output
Switch configuration		Two switches per axis Normally open at lever center position
Switch operating angle	°	. 2 to 5 either side of
Contact rating		center 3A @125Vac, 2A @ 30Vdc
Switch life minimum		100,000 cycles, cycled at 1Hz, 1A and 12Vdc
Operating temperature	°C	-25 to +85
<b>ELECTRICAL CONNECTIONS</b> Microswitch connections in the potentiometer joystick will replace the low current directional/center switches in the 16-way AMP 040 series multi-lock connector in the joystick base. In the Hall sensor joystick, switches terminate in the 8-way connector.		
<b>CAN OUTPUT VERSION</b> JC6000 with Hall sensing option can also be supplied with an integrated CANBUS output offering the J1939 protocol. This CANBUS interface meets the requirements of IEC61508 SIL level 1		
Supply voltage range	Vdc	9 to 36
CAN version		CAN 2.0b
Protocol		J1939
Under-panel sealing		IP66 IEC60529
<b>ELECTRICAL CONNECTIONS</b>		
Mating connector and pins		All connections terminate in the 6-way Deutsch DTM04-6P integrated connector P304844 (includes 390mm flying leads)

**PEJD** double axis proportional joystick  
code number: **PEJD40040D0**

with person present switch and four on-off push button switch

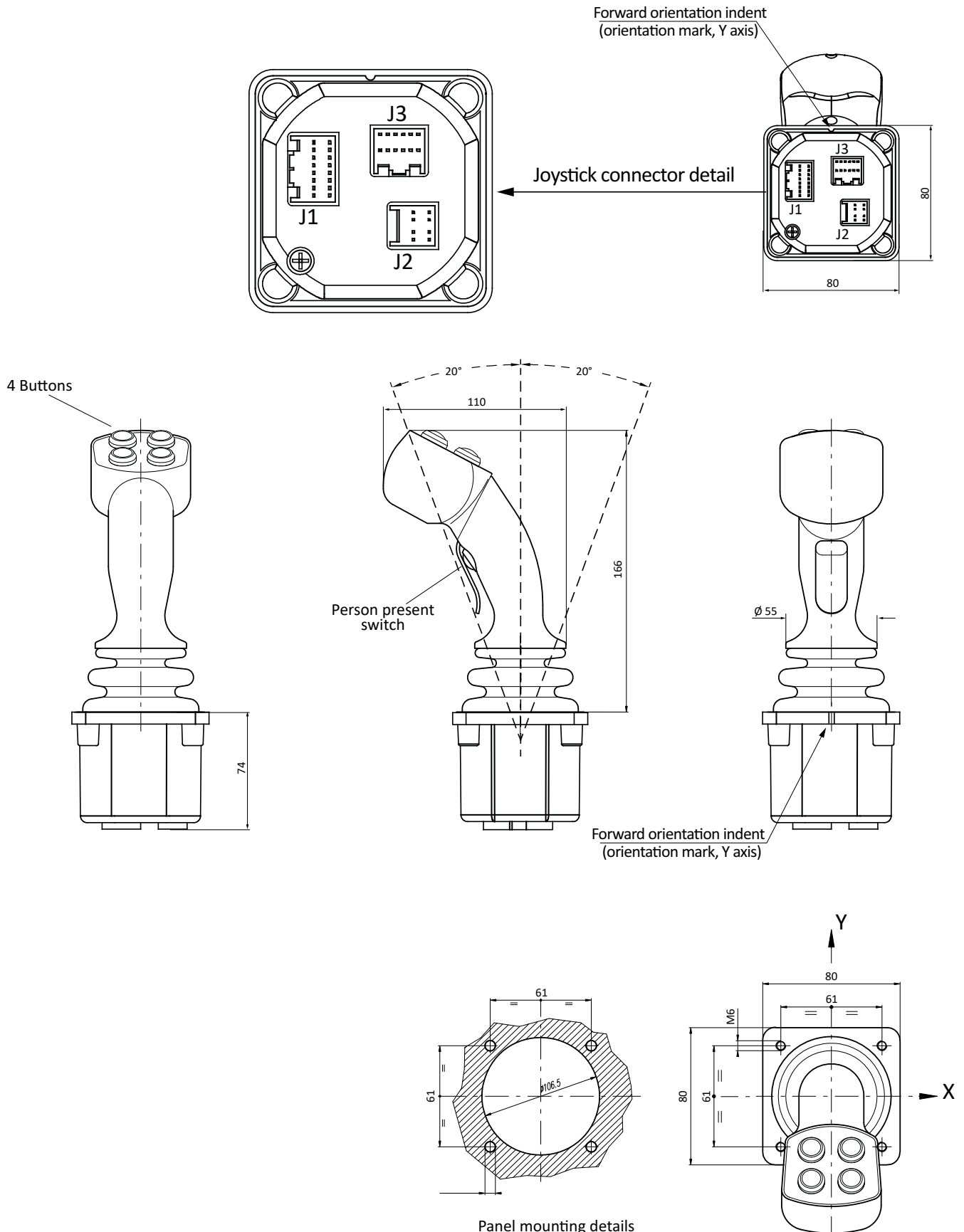

Output characteristics

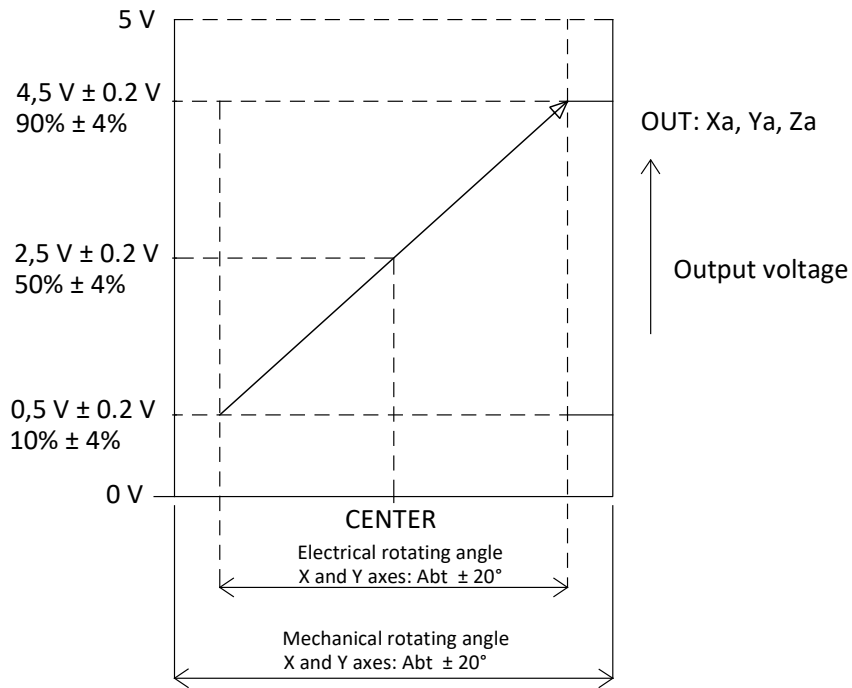

Each axes ⊖ direction ← | → Each axes ⊕ direction

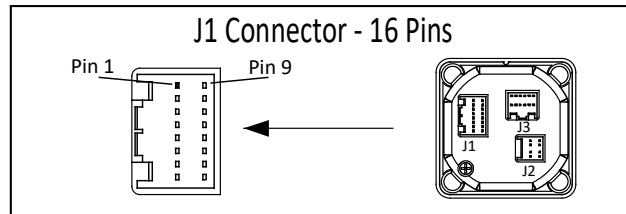

Pin	Function (potentiometer)
1	Y switch track N/O (lever forward +Y)
2	X switch track center on
3	X pot track left
4	X pot track wiper signal
5	X pot track right
6	X pot track center tap
7	X switch track common
8	X switch track N/O (lever left -X)
9	Y pot track backward
10	Y pot track wiper signal
11	Y pot track forward
12	Y pot track center tap
13	Y switch track common
14	Y switch track N/O (lever backward -Y)
15	X switch track N/O (lever right +X)
16	Y switch track center on

Faceplate options

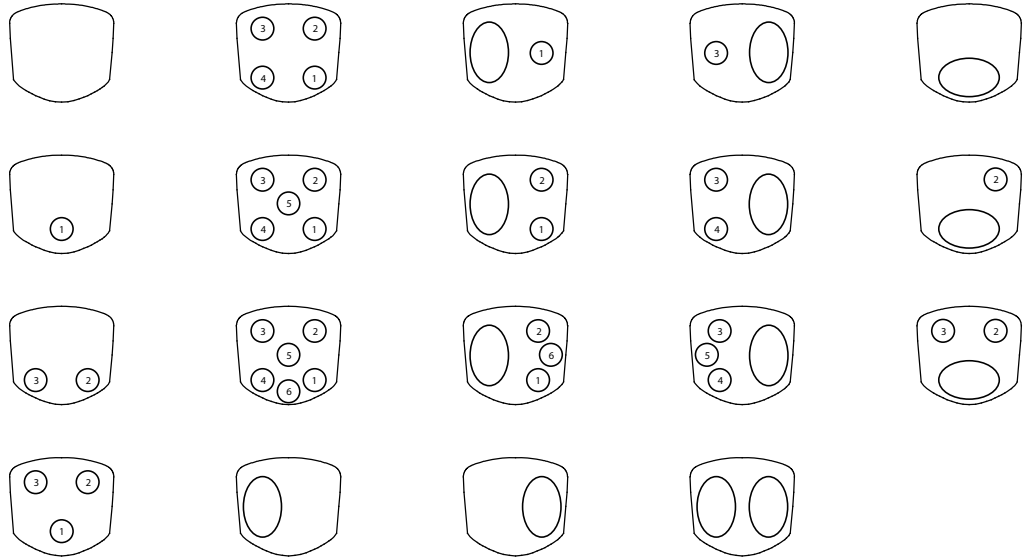
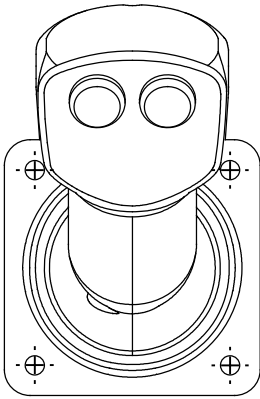

J3 Connector - 12 Pins

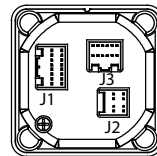
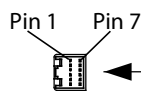

Pin	Function (Switches)	Wire color
1	Switch 4	White / Green
2	Switch 3	Blue / White
3	Switch 2	Yellow
4	Switch 1	Blue
5	Switch 5	Red
6	-	Yellow / Red
7	-	White / Red
8	Person present switch	Black / White
9	Switch 6	Violet
10	-	Pink / Grey
11	Common terminal for all switches	Black
12	Person present switch	Red / Green



HYDRAULIC POWER CONTROL

**PEJD** double axis proportional joystick  
code number: **PEJD40040D0**

with person present switch and four on-off push button switch

PERFORMANCE		
<b>MECHANICAL</b>		
Lever operating force		
breakout*	N	7 or 16
operating*	N	19 or 39 (full deflection)
maximum allowable**	N	390 (490 overload)
Lever mechanical angle		
single axis only	°	±20 forward/reverse
square gate	°	±20 in X and Y directions
Seat		preferred bias on axis
Expected life		15 million operations (5 million for potentiometer track version)
Weight	g	750 without handle fitted
* Measured at 55mm above upper flange face		** Measured 130mm above upper flange face
<b>ENVIRONMENTAL</b>		
Operating temperature	°C	-25 to +80 (-25 to +80 with microswitches)
Storage temperature	°C	-25 to +85 (-25 to +85 with microswitches)
Environmental protection(above the flange) (above the flange)		IP66 IEC 60529 (fitted with HKN handle)
Vibration		Level ±3g,10Hz to 200Hz (random) @ 3.6g(rms)
Shock		20g, 6mS, half sine profile
EMC immunity level		100V/m, 30MHz to 1GHz, 1KHz 80% sine wave modulation, EN50082-2 (1995)
EMC emissions level		Complies with EN50081-2 (1993), 150kHz to 30MHz, level B
ESD immunity level		IEC61000-4-2 level 4 8kV contact discharge, 15kV air discharge
<b>ELECTRICAL – HALL EFFECT SENSOR</b>		
Resolution		Infinite
Supply voltage range	Vdc	5 ± 0.5 regulated transient free
Over voltage (maximum)	Vdc	15 continuous
Reverse polarity (maximum)	Vdc	14.5
Output voltage span - options	Vdc	±25% span - nominal 1.1 to 3.9
		±30% span - nominal 1.0 to 4.0
		±40% span - nominal 0.5 to 4.5
Load impedance (minimum)	kΩ	5
Center voltage (no load)	%	48 - 52 of supply voltage
Current consumption	mA	13 per axis (6.5 per sensor)
Insulation resistance		Greater than 50MΩ at 50Vdc
Output sense		The dual outputs rise together in the same direction, increasing with lever forward (and right), decreasing with lever backward (and left)
Output matching		See maximum output difference diagram below
<b>ELECTRICAL CONNECTIONS</b>		
Mating 12 way connector and pins		SA48061 (AMP 040 12 way connector 174045-2; pins 175062-1)
Mating 12 way harness		P49779 (connector, pins and 380mm long cable)





HYDRAULIC POWER CONTROL

**PEJD** double axis proportional joystick  
code number: **PEJD40040D0**

with person present switch and four on-off push button switch

<b>ELECTRICAL – POTENTIOMETER TRACK</b>		
Resolution		Virtually infinite
Track resistance $\hat{A}\pm 20\%$	K $\Omega$	1.8, 2, 2.9, 5
Track operating angle	$^{\circ}$	$\pm 18$
Output voltage range	%	0-100, 10-90, 25-75 of input
Center tap voltage	%	48 - 52 of applied voltage
Center tap angle	$^{\circ}$	$\pm 2.5$
Center tap to switch alignment	$^{\circ}$	Within 0.5
Supply voltage maximum	Vdc	32
Wiper circuit impedance	M $\Omega$	1 minimum recommended*
Power dissipation @ 25°C	W	0.25
Insulation resistance		Greater than 15M $\hat{I}$ @ 50Vdc
* The long life resistive elements require a high impedance load in the wiper circuit to minimise the current flowing through the wiper for optimum life conditions		
<b>ELECTRICAL – DIRECTIONAL OR CENTER SWITCH (LOW CURRENT)</b>		
		Not available with CANbus output
Switch operating angle	$^{\circ}$	1.5 or 5 either side of center
Supply voltage maximum	Vdc	35
Load current maximum	mA	200 resistive
<b>ELECTRICAL CONNECTIONS</b>		
All primary potentiometer track and directional/center switch connections terminate in a 16-way AMP 040 series multi-lock connector in the joystick base. Secondary potentiometer track connections terminate in an 8-way AMP 040 series multi-lock connector.		
Mating 16 way connector and pins		SA47931 (AMP 040 16 way connector 174046-2; Pins 175062-1)
Mating 16 way harness		P49780 (connector, pins and 380mm long cable)
Mating 8 way connector and pins		SA304522 (AMP 040 8 way connector 174044-2; pins 175062-1)
Mating 8 way harness		P303083 (connector, pins and 380mm long cable)
<b>ELECTRICAL MICROSWITCH</b>		
		Not available with CANbus output
Switch configuration		Two switches per axis Normally open at lever center position
Switch operating angle	$^{\circ}$	. 2 to 5 either side of
Contact rating		center 3A @125Vac, 2A @ 30Vdc
Switch life minimum		100,000 cycles, cycled at 1Hz, 1A and 12Vdc
Operating temperature	$^{\circ}\text{C}$	-25 to +85
<b>ELECTRICAL CONNECTIONS</b>		
Microswitch connections in the potentiometer joystick will replace the low current directional/center switches in the 16-way AMP 040 series multi-lock connector in the joystick base. In the Hall sensor joystick, switches terminate in the 8-way connector.		
<b>CAN OUTPUT VERSION</b>		
JC6000 with Hall sensing option can also be supplied with an integrated CANBUS output offering the J1939 protocol. This CANBUS interface meets the requirements of IEC61508 SIL level 1		
Supply voltage range	Vdc	9 to 36
CAN version		CAN 2.0b
Protocol		J1939
Under-panel sealing		IP66 IEC60529
<b>ELECTRICAL CONNECTIONS</b>		
Mating connector and pins		All connections terminate in the 6-way Deutsch DTM04-6P integrated connector P304844 (includes 390mm flying leads)

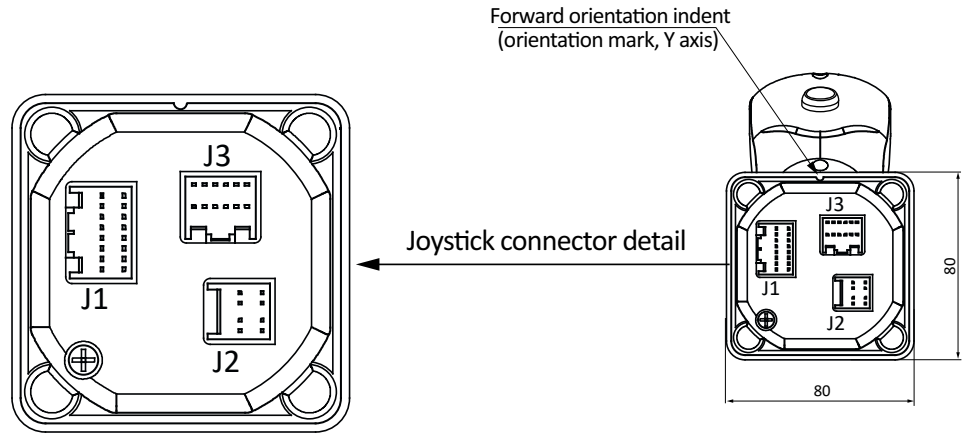

2 Button switches with plastic cover protections

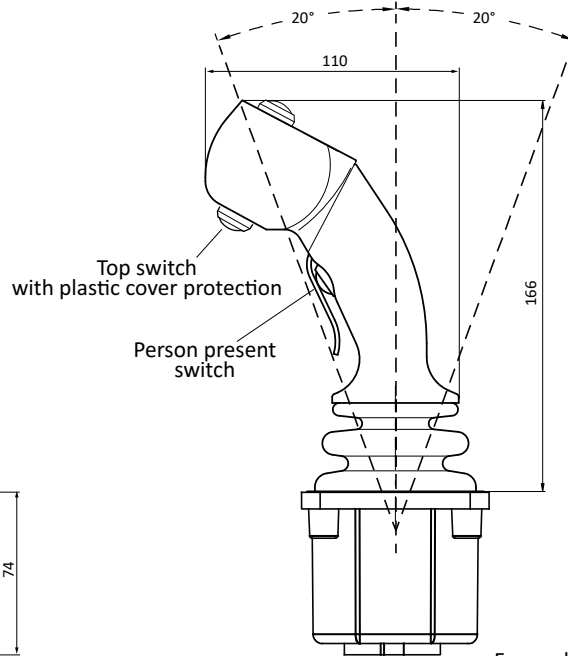
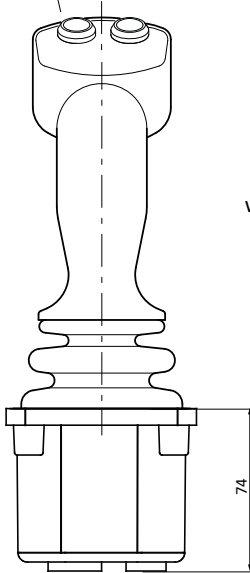

Forward orientation indent  
(orientation mark, Y axis)

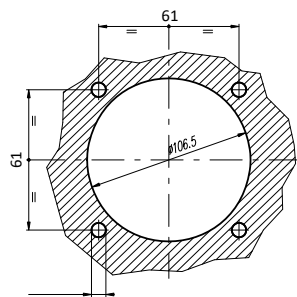
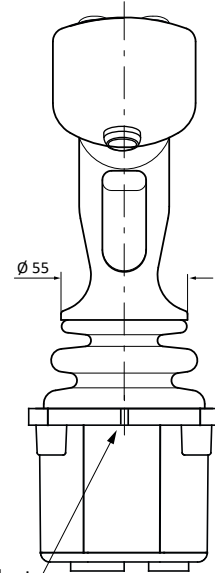

Panel mounting details

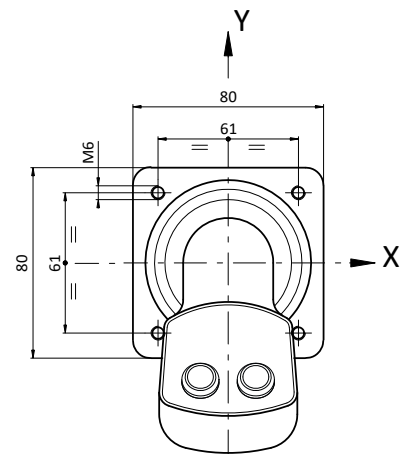

Output characteristics

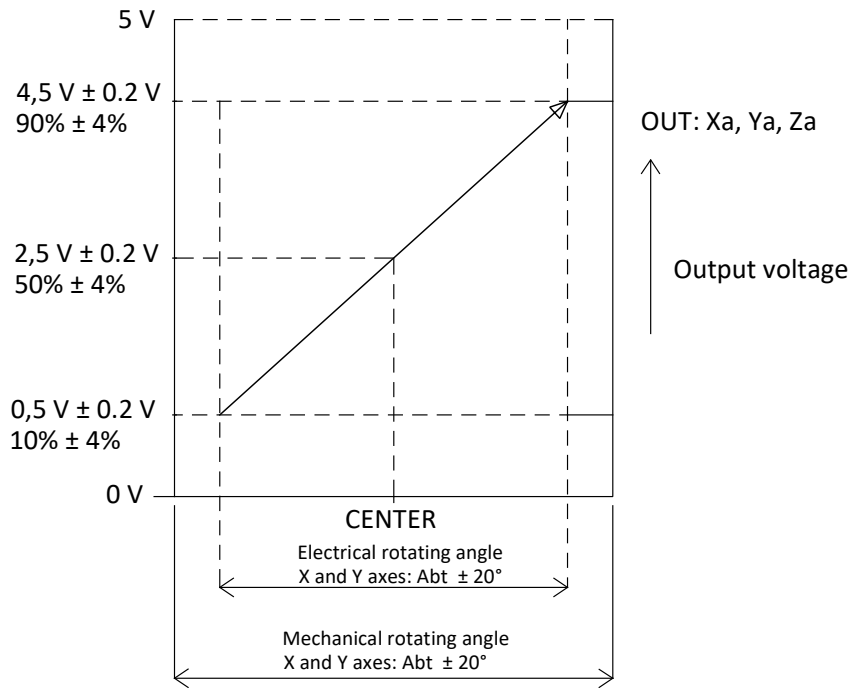

Each axes ⊖ direction ← | → Each axes ⊕ direction

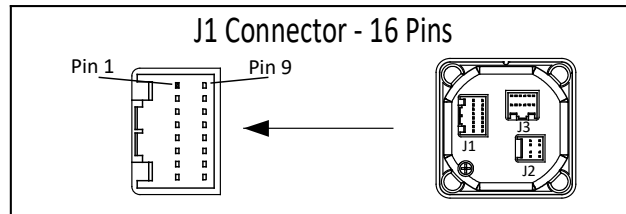

Pin	Function (potentiometer)
1	Y switch track N/O (lever forward +Y)
2	X switch track center on
3	X pot track left
4	X pot track wiper signal
5	X pot track right
6	X pot track center tap
7	X switch track common
8	X switch track N/O (lever left -X)
9	Y pot track backward
10	Y pot track wiper signal
11	Y pot track forward
12	Y pot track center tap
13	Y switch track common
14	Y switch track N/O (lever backward -Y)
15	X switch track N/O (lever right +X)
16	Y switch track center on

Faceplate options

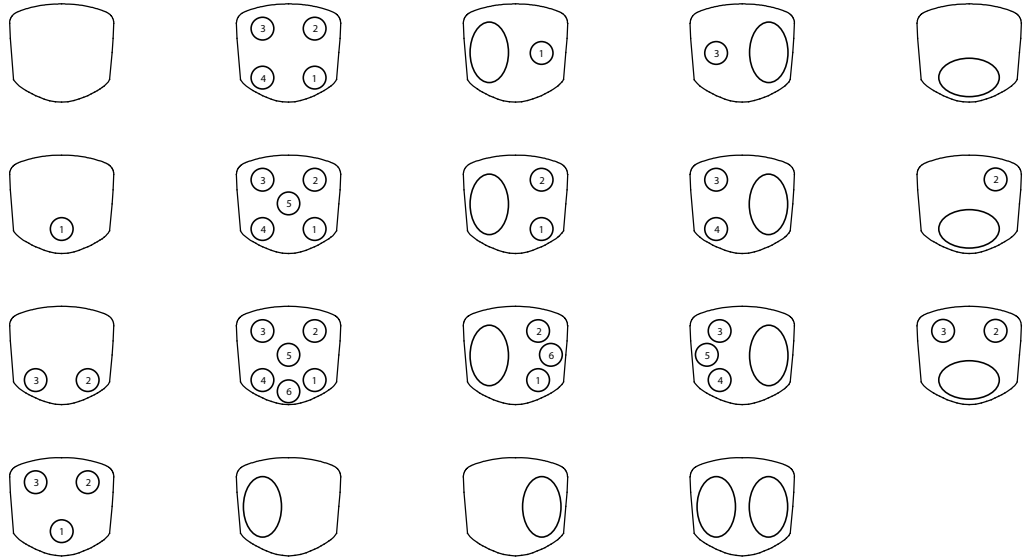
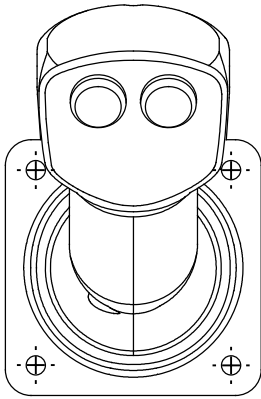

J3 Connector - 12 Pins



Pin	Function (Switches)	Wire color
1	Switch 4	White / Green
2	Switch 3	Blue / White
3	Switch 2	Yellow
4	Switch 1	Blue
5	Switch 5	Red
6	-	Yellow / Red
7	-	White / Red
8	Person present switch	Black / White
9	Switch 6	Violet
10	-	Pink / Grey
11	Common terminal for all switches	Black
12	Person present switch	Red / Green



HYDRAULIC POWER CONTROL

**PEJD** double axis proportional joystick  
 code number: **PEJD40020B0** with person present switch,  
 three on-off push button switches and safety plus gate

PERFORMANCE		
<b>MECHANICAL</b>		
Lever operating force		
breakout*	N	7 or 16
operating*	N	19 or 39 (full deflection)
maximum allowable**	N	390 (490 overload)
Lever mechanical angle		
single axis only	°	±20 forward/reverse
square gate	°	±20 in X and Y directions
Seat		preferred bias on axis
Expected life		15 million operations (5 million for potentiometer track version)
Weight	g	750 without handle fitted
* Measured at 55mm above upper flange face		** Measured 130mm above upper flange face
<b>ENVIRONMENTAL</b>		
Operating temperature	°C	-25 to +80 (-25 to +80 with microswitches)
Storage temperature	°C	-25 to +85 (-25 to +85 with microswitches)
Environmental protection(above the flange) (above the flange)		IP66 IEC 60529 (fitted with HKN handle)
Vibration		Level ±3g,10Hz to 200Hz (random) @ 3.6g(rms)
Shock		20g, 6mS, half sine profile
EMC immunity level		100V/m, 30MHz to 1GHz, 1kHz 80% sine wave modulation, EN50082-2 (1995)
EMC emissions level		Complies with EN50081-2 (1993), 150kHz to 30MHz, level B
ESD immunity level		IEC61000-4-2 level 4 8kV contact discharge, 15kV air discharge
<b>ELECTRICAL – HALL EFFECT SENSOR</b>		
Resolution		Infinite
Supply voltage range	Vdc	5 ± 0.5 regulated transient free
Over voltage (maximum)	Vdc	15 continuous
Reverse polarity (maximum)	Vdc	14.5
Output voltage span - options	Vdc	±25% span - nominal 1.1 to 3.9
		±30% span - nominal 1.0 to 4.0
		±40% span - nominal 0.5 to 4.5
Load impedance (minimum)	kΩ	5
Center voltage (no load)	%	48 - 52 of supply voltage
Current consumption	mA	13 per axis (6.5 per sensor)
Insulation resistance		Greater than 50MΩ at 50Vdc
Output sense		The dual outputs rise together in the same direction, increasing with lever forward (and right), decreasing with lever backward (and left)
Output matching		See maximum output difference diagram below
<b>ELECTRICAL CONNECTIONS</b>		
Mating 12 way connector and pins		SA48061 (AMP 040 12 way connector 174045-2; pins 175062-1)
Mating 12 way harness		P49779 (connector, pins and 380mm long cable)



HYDRAULIC POWER CONTROL

**PEJD** double axis proportional joystick  
code number: **PEJD40020B0** with person present switch,  
three on-off push button switches and safety plus gate

<b>ELECTRICAL – POTENTIOMETER TRACK</b>		
Resolution		Virtually infinite
Track resistance $\hat{A}\pm 20\%$	K $\Omega$	1.8, 2, 2.9, 5
Track operating angle	$^{\circ}$	$\pm 18$
Output voltage range	%	0-100, 10-90, 25-75 of input
Center tap voltage	%	48 - 52 of applied voltage
Center tap angle	$^{\circ}$	$\pm 2.5$
Center tap to switch alignment	$^{\circ}$	Within 0.5
Supply voltage maximum	Vdc	32
Wiper circuit impedance	M $\Omega$	1 minimum recommended*
Power dissipation @ 25°C	W	0.25
Insulation resistance		Greater than 15M $\hat{I}$ @ 50Vdc
* The long life resistive elements require a high impedance load in the wiper circuit to minimise the current flowing through the wiper for optimum life conditions		
<b>ELECTRICAL – DIRECTIONAL OR CENTER SWITCH (LOW CURRENT)</b>		
		Not available with CANbus output
Switch operating angle	$^{\circ}$	1.5 or 5 either side of center
Supply voltage maximum	Vdc	35
Load current maximum	mA	200 resistive
<b>ELECTRICAL CONNECTIONS</b>		
All primary potentiometer track and directional/center switch connections terminate in a 16-way AMP 040 series multi-lock connector in the joystick base. Secondary potentiometer track connections terminate in an 8-way AMP 040 series multi-lock connector.		
Mating 16 way connector and pins		SA47931 (AMP 040 16 way connector 174046-2; Pins 175062-1)
Mating 16 way harness		P49780 (connector, pins and 380mm long cable)
Mating 8 way connector and pins		SA304522 (AMP 040 8 way connector 174044-2; pins 175062-1)
Mating 8 way harness		P303083 (connector, pins and 380mm long cable)
<b>ELECTRICAL MICROSWITCH</b>		
		Not available with CANbus output
Switch configuration		Two switches per axis Normally open at lever center position
Switch operating angle	$^{\circ}$	. 2 to 5 either side of
Contact rating		center 3A @125Vac, 2A @ 30Vdc
Switch life minimum		100,000 cycles, cycled at 1Hz, 1A and 12Vdc
Operating temperature	$^{\circ}\text{C}$	-25 to +85
<b>ELECTRICAL CONNECTIONS</b>		
Microswitch connections in the potentiometer joystick will replace the low current directional/center switches in the 16-way AMP 040 series multi-lock connector in the joystick base. In the Hall sensor joystick, switches terminate in the 8-way connector.		
<b>CAN OUTPUT VERSION</b>		
JC6000 with Hall sensing option can also be supplied with an integrated CANBUS output offering the J1939 protocol. This CANBUS interface meets the requirements of IEC61508 SIL level 1		
Supply voltage range	Vdc	9 to 36
CAN version		CAN 2.0b
Protocol		J1939
Under-panel sealing		IP66 IEC60529
<b>ELECTRICAL CONNECTIONS</b>		
Mating connector and pins		All connections terminate in the 6-way Deutsch DTM04-6P integrated connector P304844 (includes 390mm flying leads)

Mechanical dimensions

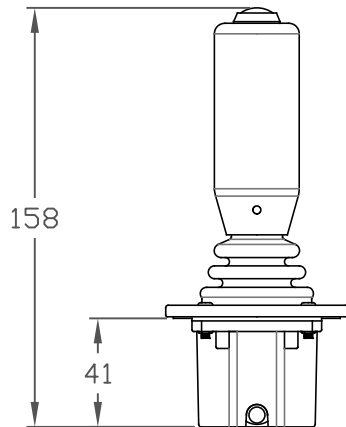

Joystick angle movement

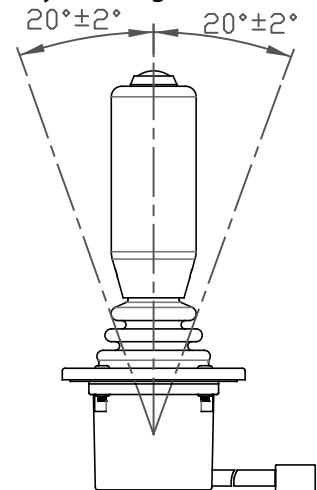

Bottom view

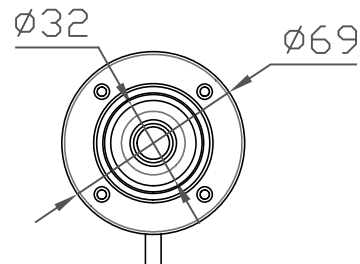

Panel cutout

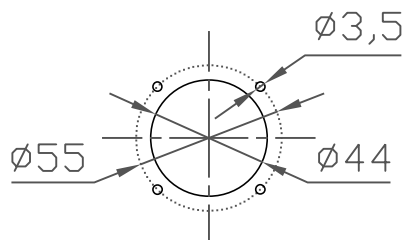

Direction of lever operation

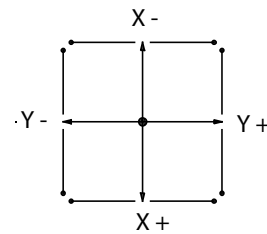

### Output characteristics

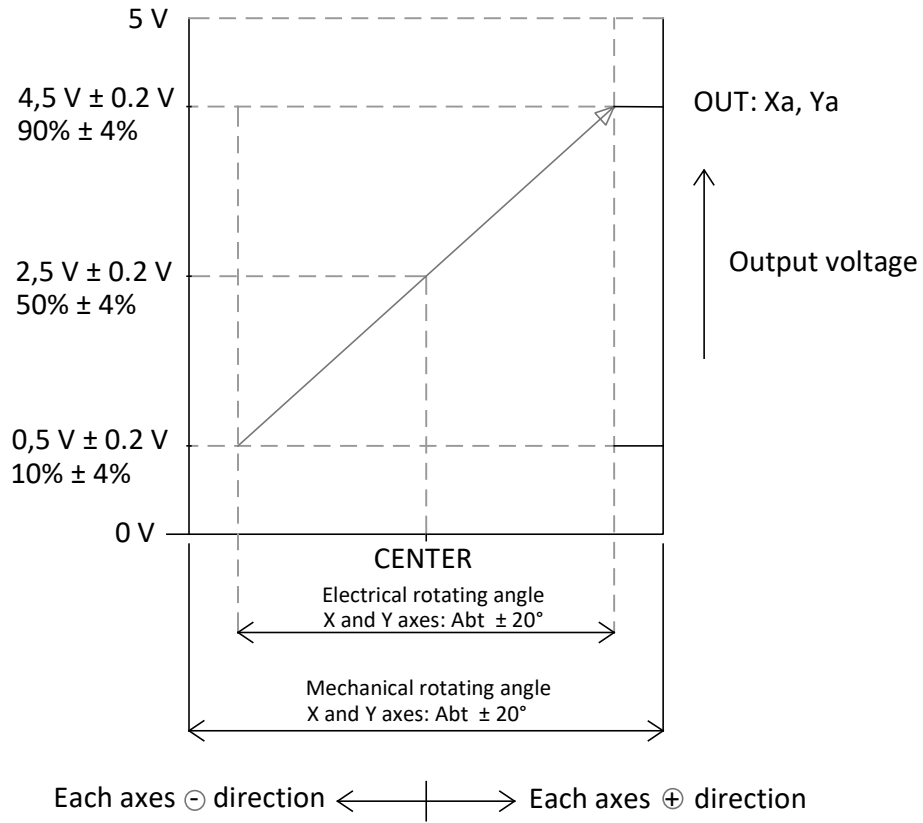

### Terminal configuration

DTM04-6P

Pin	Function	Color	Part number
1	+5VDC - X, Y	Red	
2	XA	White	
3	YA	Blue	
4	-	-	
5	GND - X, Y	Black	
6	-	-	
Flying Leads	PB	Grey	
	PB	Grey	



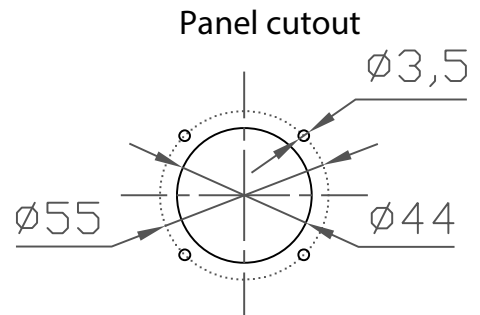
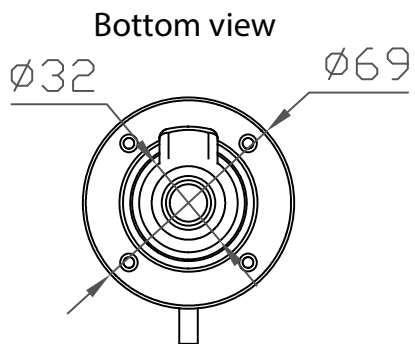
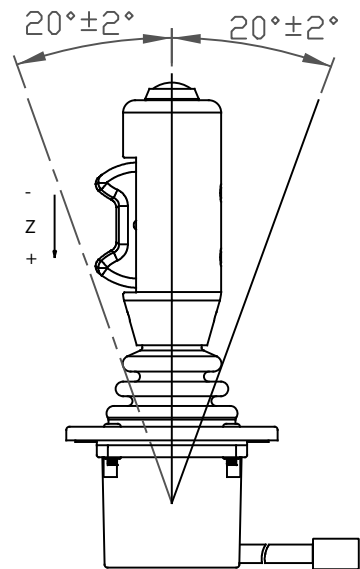
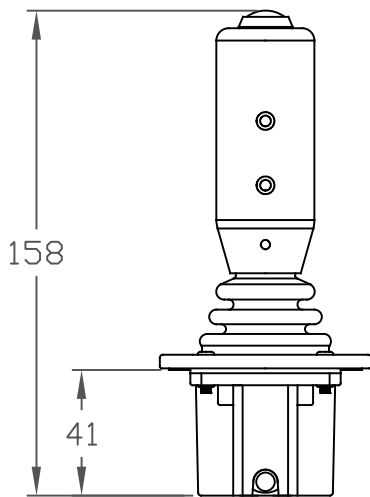

### Output characteristics

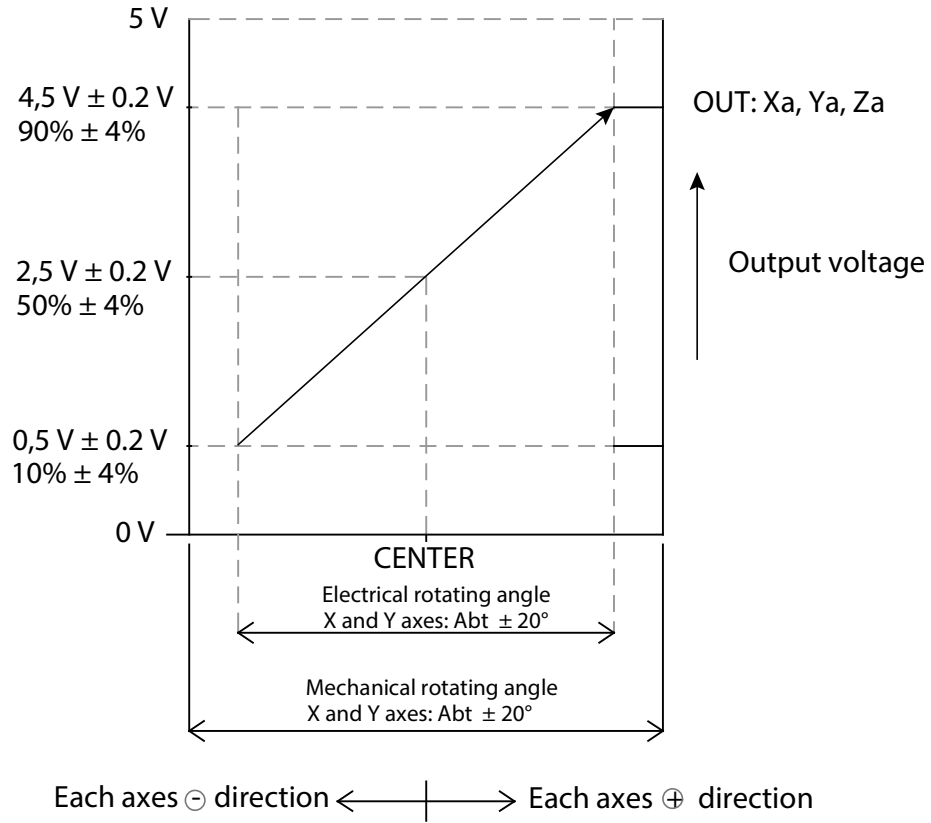

### Terminal configuration

DTM04-6P

Pin	Function	Color	Part number
1	+5VDC - X, Y, Z	Red	
2	XA	White	
3	YA	Blue	
4	ZA	Yellow	
5	GND - X, Y, Z	Black	
6	-	-	
Flying Leads	PB	Grey	
	PB	Grey	

**PEJD joystick controller multifunction grip - Right version**Code number: **PEJD2002B0D**

4 proportional axis, 2 on-off push button, person present switch

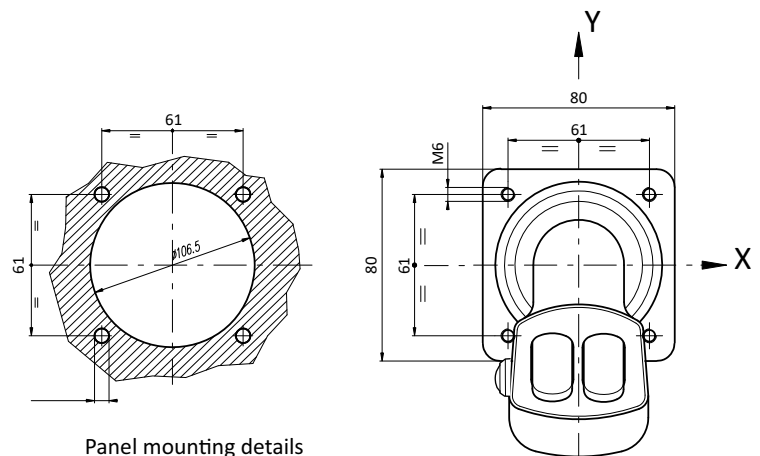
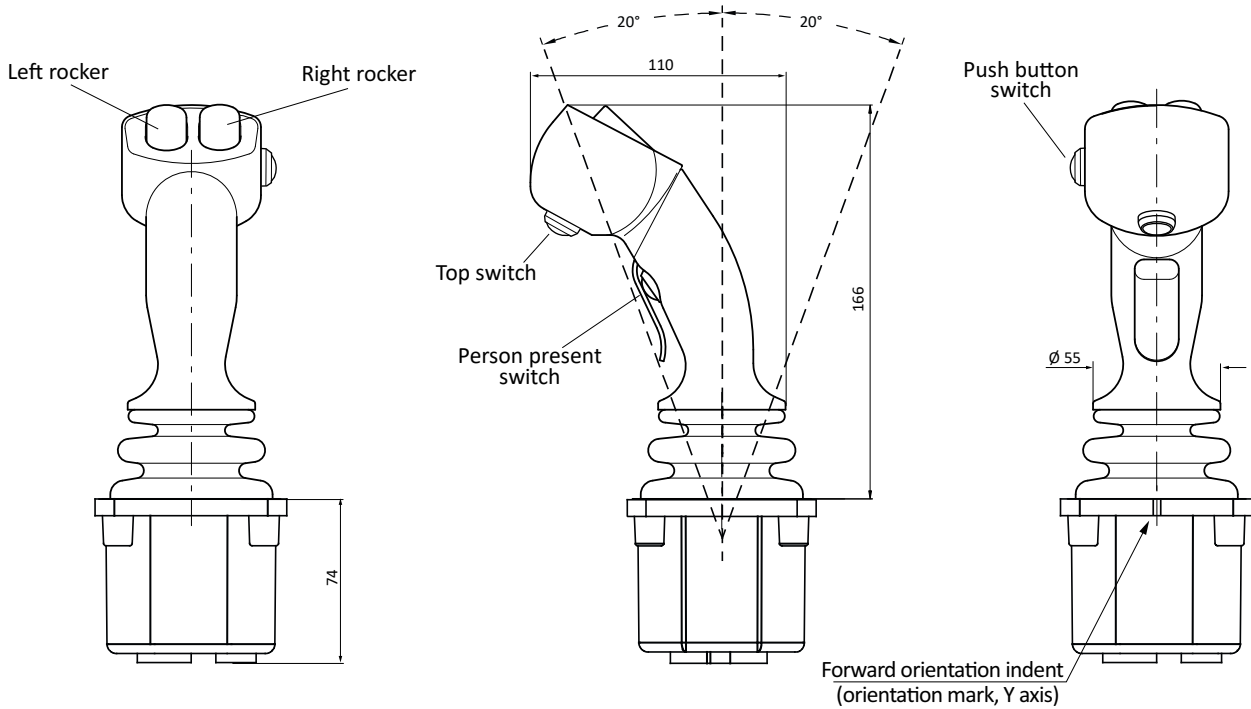
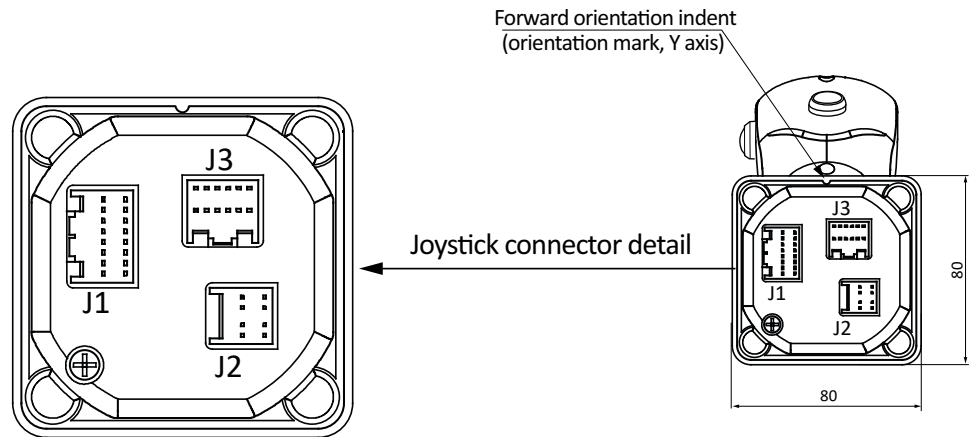

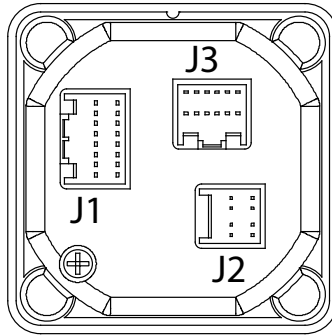

**J1 connector**

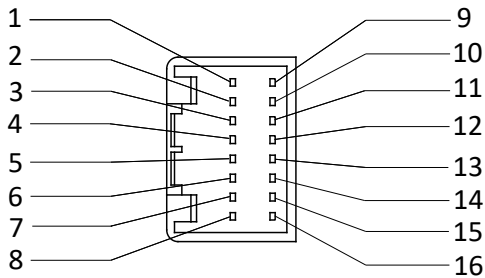

Pin	Function (potentiometer)
1	Y switch track N/O (lever forward +Y)
2	X switch track center on
3	X pot track left
4	X pot track wiper signal
5	X pot track right
6	X pot track center tap
7	X switch track common
8	X switch track N/O (lever left -X)
9	Y pot track backward
10	Y pot track wiper signal
11	Y pot track forward
12	Y pot track center tap
13	Y switch track common
14	Y switch track N/O (lever backward -Y)
15	X switch track N/O (lever right +X)
16	Y switch track center on

**J3 connector**

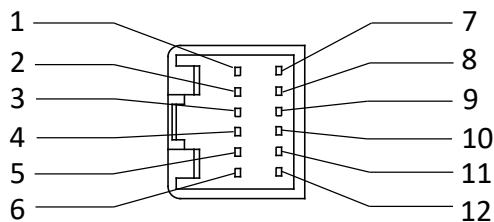

Pin	Function (Rocker)
1	Left switch backward
2	Left switch forward or horizontal left
3	-
4	-
5	Left output or horizontal output signal
6	Rocker center tap
7	Rocker positive power supply U+
8	-
9	-
10	Rocker negative power supply U-
11	Rocker switch common
12	-

Output characteristics

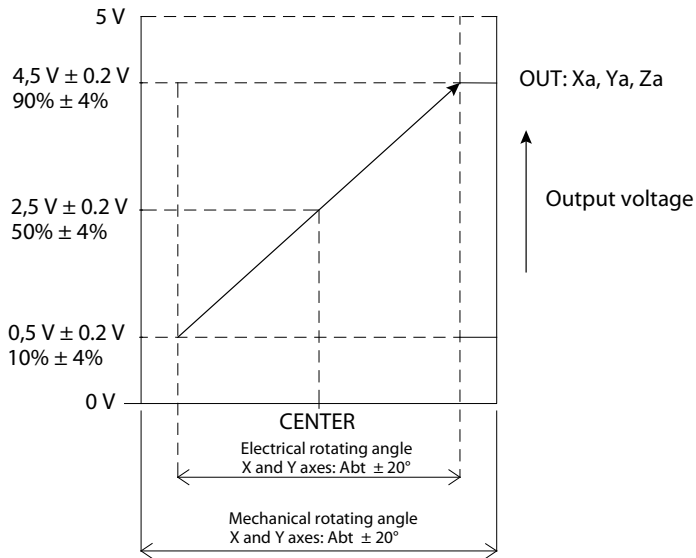

Each axes ⊖ direction ← | → Each axes ⊕ direction

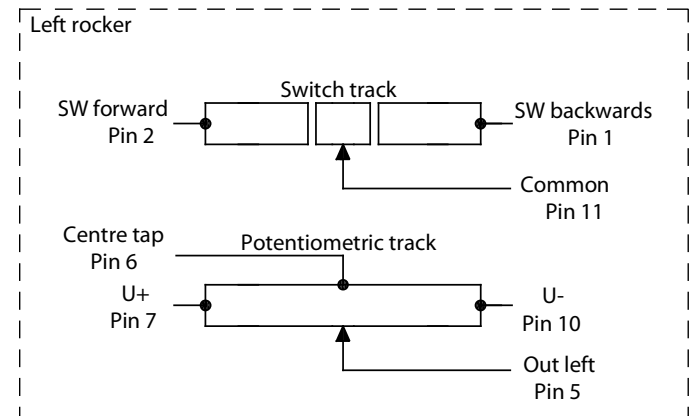
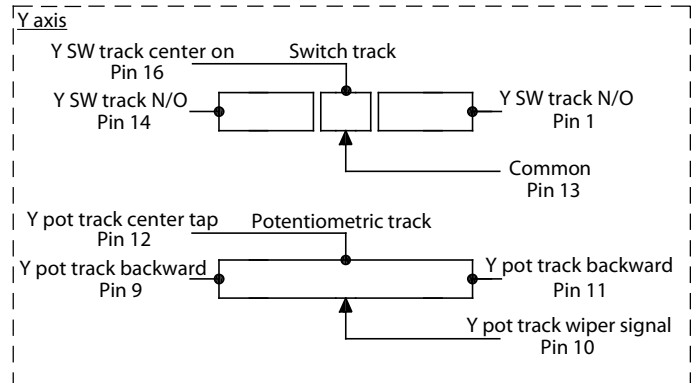
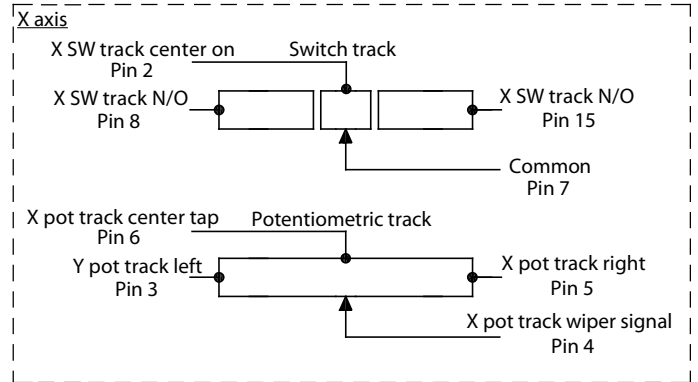



HYDRAULIC POWER CONTROL

**PEJD joystick controller multifunction grip**

Code number: **PEJD2002B0D**

4 proportional axis, 2 on-off push button, person present switch

<b>PERFORMANCE</b>		
<b>MECHANICAL</b>		
Lever operating force		
breakout*	N	7 or 16
operating*	N	19 or 39 (full deflection)
maximum allowable**	N	390 (490 overload)
Lever mechanical angle		
single axis only	°	±20 forward/reverse
square gate	°	±20 in X and Y directions
Seat		preferred bias on axis
Expected life		15 million operations (5 million for potentiometer track version)
Weight	g	750 without handle fitted
* Measured at 55mm above upper flange face		** Measured 130mm above upper flange face
<b>ENVIRONMENTAL</b>		
Operating temperature	°C	-25 to +80 (-25 to +80 with microswitches)
Storage temperature	°C	-25 to +85 (-25 to +85 with microswitches)
Environmental protection(above the flange) (above the flange)		IP66 IEC 60529 (fitted with HKN handle)
Vibration		Level ±3g,10Hz to 200Hz (random) @ 3.6g(rms)
Shock		20g, 6mS, half sine profile
EMC immunity level		100V/m, 30MHz to 1GHz, 1KHz 80% sine wave modulation, EN50082-2 (1995)
EMC emissions level		Complies with EN50081-2 (1993), 150kHz to 30MHz, level B
ESD immunity level		IEC61000-4-2 level 4 8kV contact discharge, 15kV air discharge
<b>ELECTRICAL – HALL EFFECT SENSOR</b>		
Resolution		Infinite
Supply voltage range	Vdc	5 ± 0.5 regulated transient free
Over voltage (maximum)	Vdc	15 continuous
Reverse polarity (maximum)	Vdc	14.5
Output voltage span - options	Vdc	±25% span - nominal 1.1 to 3.9
		±30% span - nominal 1.0 to 4.0
		±40% span - nominal 0.5 to 4.5
Load impedance (minimum)	kΩ	5
Center voltage (no load)	%	48 - 52 of supply voltage
Current consumption	mA	13 per axis (6.5 per sensor)
Insulation resistance		Greater than 50MΩ at 50Vdc
Output sense		The dual outputs rise together in the same direction, increasing with lever forward (and right), decreasing with lever backward (and left)
Output matching		See maximum output difference diagram below
<b>ELECTRICAL CONNECTIONS</b>		
Mating 12 way connector and pins		SA48061 (AMP 040 12 way connector 174045-2; pins 175062-1)
Mating 12 way harness		P49779 (connector, pins and 380mm long cable)

**PEJD joystick controller multifunction grip - Left version**Code number: **PEJD2002B0S**

4 proportional axis, 2 on-off push button, person present switch

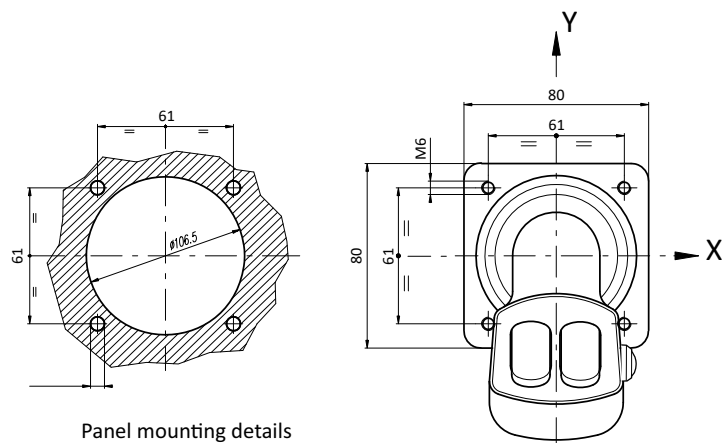
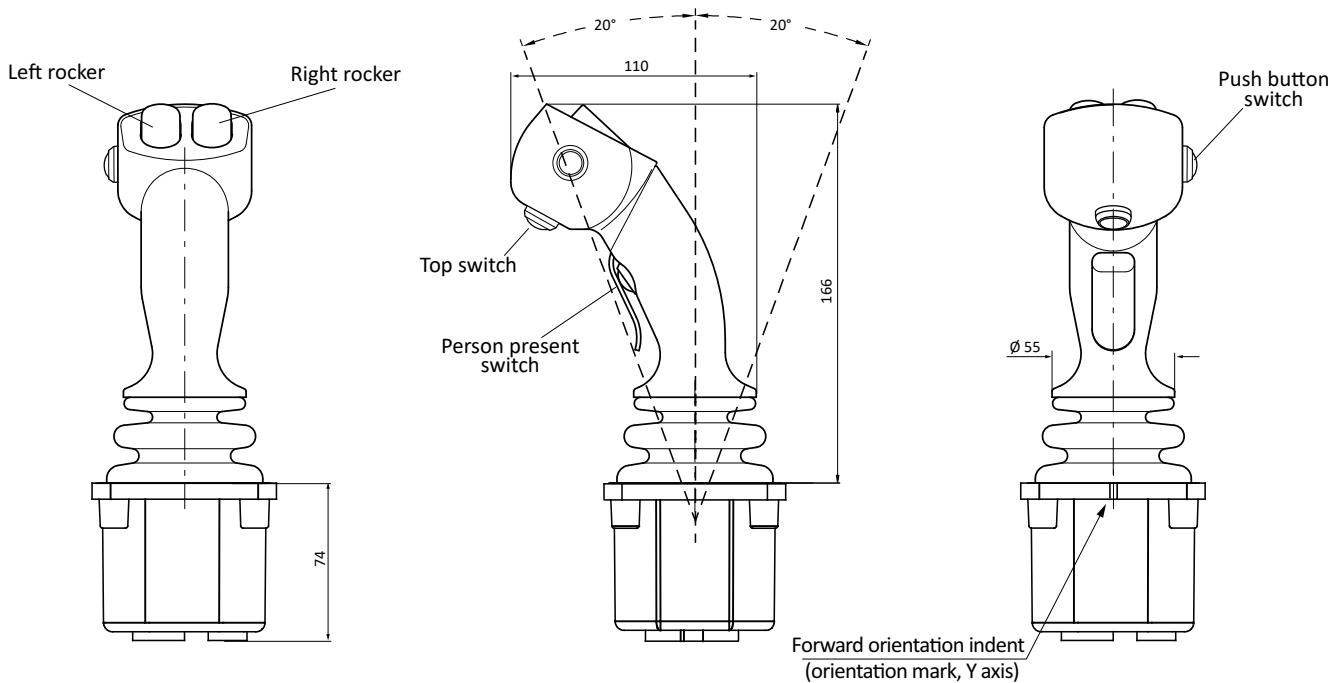
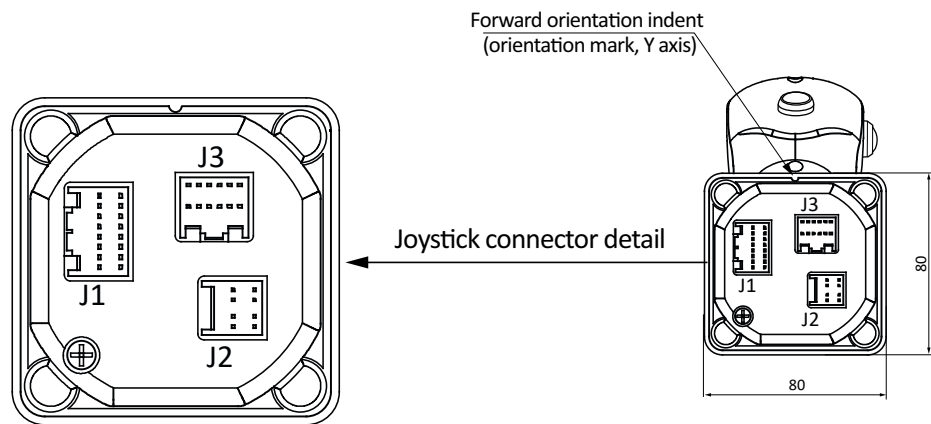

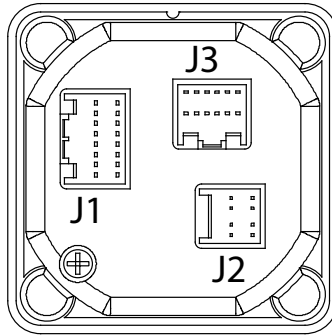

**J1 connector**

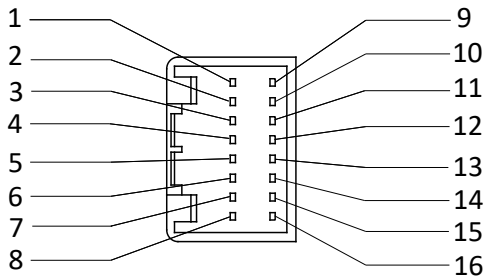

Pin	Function (potentiometer)
1	Y switch track N/O (lever forward +Y)
2	X switch track center on
3	X pot track left
4	X pot track wiper signal
5	X pot track right
6	X pot track center tap
7	X switch track common
8	X switch track N/O (lever left -X)
9	Y pot track backward
10	Y pot track wiper signal
11	Y pot track forward
12	Y pot track center tap
13	Y switch track common
14	Y switch track N/O (lever backward -Y)
15	X switch track N/O (lever right +X)
16	Y switch track center on

**J3 connector**

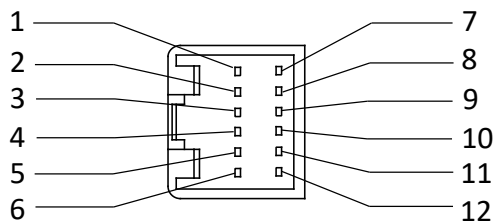

Pin	Function (Rocker)
1	Left switch backward
2	Left switch forward or horizontal left
3	-
4	-
5	Left output or horizontal output signal
6	Rocker center tap
7	Rocker positive power supply U+
8	-
9	-
10	Rocker negative power supply U-
11	Rocker switch common
12	-



Output characteristics

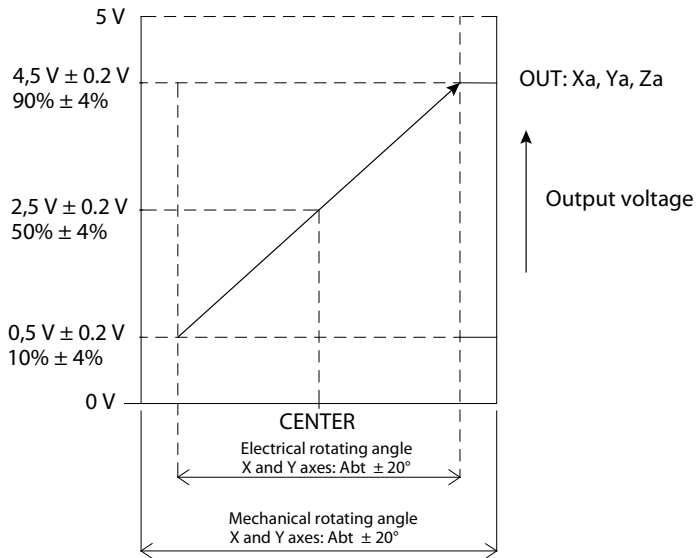

Each axes ⊖ direction ← | → Each axes ⊕ direction

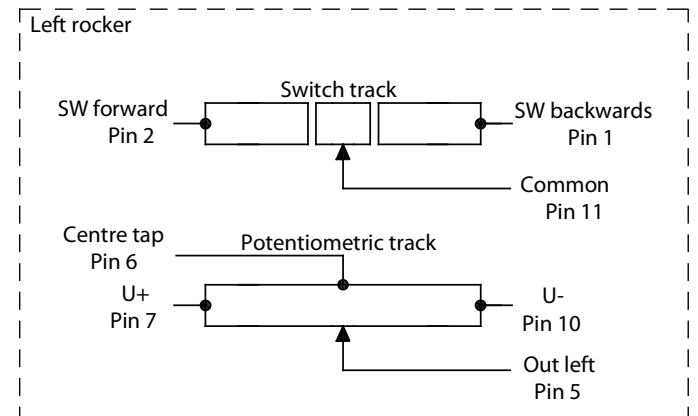
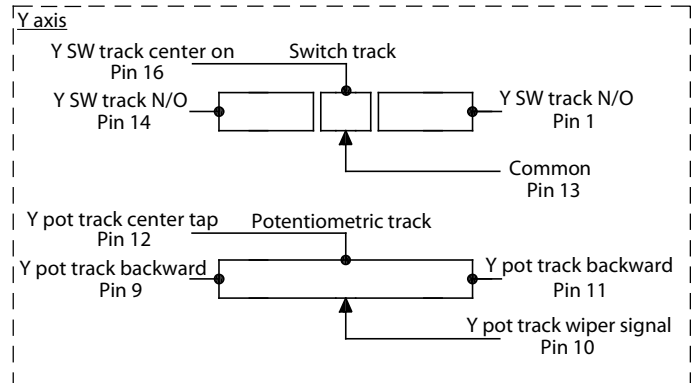
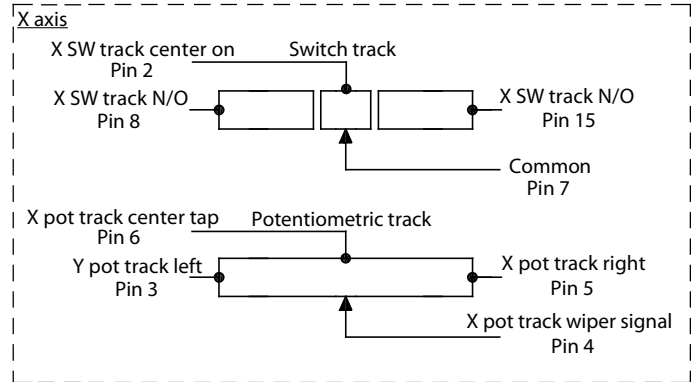



HYDRAULIC POWER CONTROL

**PEJD joystick controller multifunction grip - Left version**

Code number: **PEJD2002B0S**

4 proportional axis, 2 on-off push button, person present switch

<b>PERFORMANCE</b>		
<b>MECHANICAL</b>		
Lever operating force		
breakout*	N	7 or 16
operating*	N	19 or 39 (full deflection)
maximum allowable**	N	390 (490 overload)
Lever mechanical angle		
single axis only	°	±20 forward/reverse
square gate	°	±20 in X and Y directions
Seat		preferred bias on axis
Expected life		15 million operations (5 million for potentiometer track version)
Weight	g	750 without handle fitted
* Measured at 55mm above upper flange face		** Measured 130mm above upper flange face
<b>ENVIRONMENTAL</b>		
Operating temperature	°C	-25 to +80 (-25 to +80 with microswitches)
Storage temperature	°C	-25 to +85 (-25 to +85 with microswitches)
Environmental protection(above the flange) (above the flange)		IP66 IEC 60529 (fitted with HKN handle)
Vibration		Level ±3g,10Hz to 200Hz (random) @ 3.6g(rms)
Shock		20g, 6mS, half sine profile
EMC immunity level		100V/m, 30MHz to 1GHz, 1KHz 80% sine wave modulation, EN50082-2 (1995)
EMC emissions level		Complies with EN50081-2 (1993), 150kHz to 30MHz, level B
ESD immunity level		IEC61000-4-2 level 4 8kV contact discharge, 15kV air discharge
<b>ELECTRICAL – HALL EFFECT SENSOR</b>		
Resolution		Infinite
Supply voltage range	Vdc	5 ± 0.5 regulated transient free
Over voltage (maximum)	Vdc	15 continuous
Reverse polarity (maximum)	Vdc	14.5
Output voltage span - options	Vdc	±25% span - nominal 1.1 to 3.9
		±30% span - nominal 1.0 to 4.0
		±40% span - nominal 0.5 to 4.5
Load impedance (minimum)	kΩ	5
Center voltage (no load)	%	48 - 52 of supply voltage
Current consumption	mA	13 per axis (6.5 per sensor)
Insulation resistance		Greater than 50MΩ at 50Vdc
Output sense		The dual outputs rise together in the same direction, increasing with lever forward (and right), decreasing with lever backward (and left)
Output matching		See maximum output difference diagram below
<b>ELECTRICAL CONNECTIONS</b>		
Mating 12 way connector and pins		SA48061 (AMP 040 12 way connector 174045-2; pins 175062-1)
Mating 12 way harness		P49779 (connector, pins and 380mm long cable)

**PEJD** joystick controller multifunction grip - Right version  
Code number: **PEJD2000LOD**  
3 proportional axis

Forward orientation indent  
(orientation mark, Y axis)

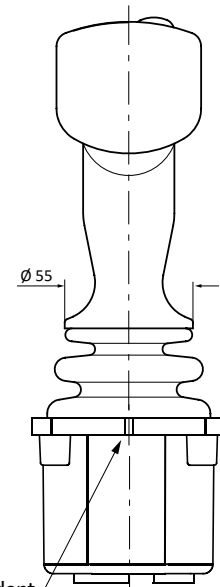
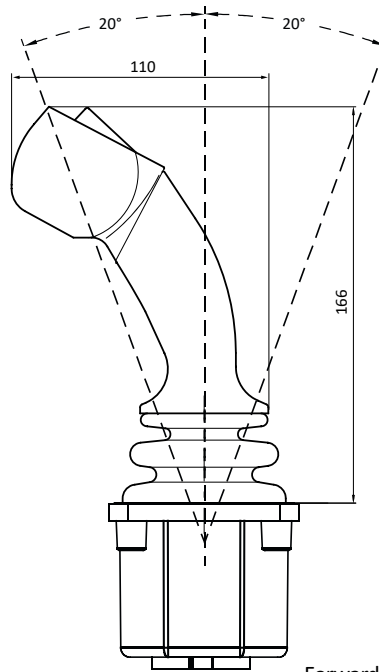
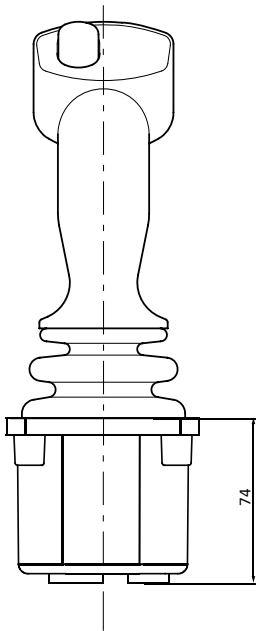
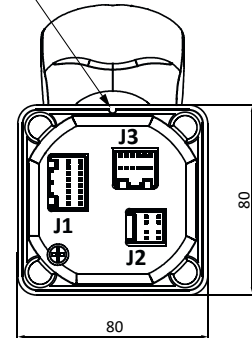

Forward orientation indent  
(orientation mark, Y axis)

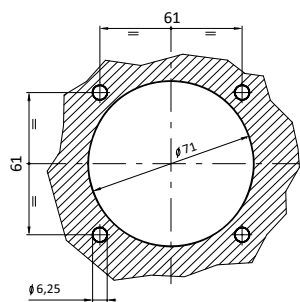

Panel mounting details

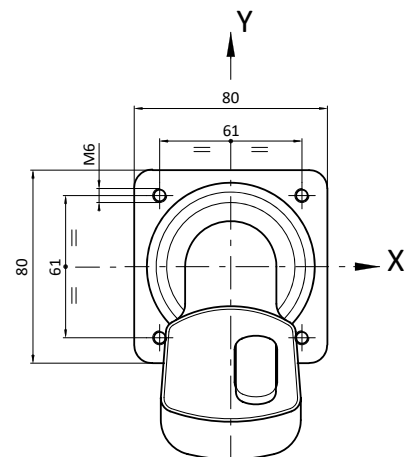

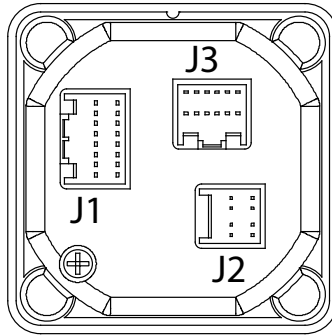

**J1 connector**

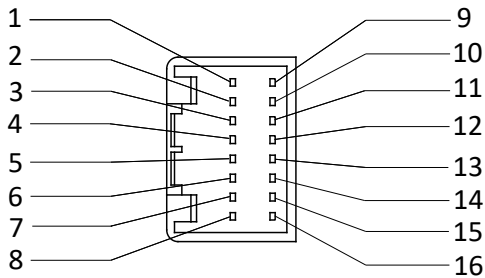

Pin	Function (potentiometer)
1	Y switch track N/O (lever forward +Y)
2	X switch track center on
3	X pot track left
4	X pot track wiper signal
5	X pot track right
6	X pot track center tap
7	X switch track common
8	X switch track N/O (lever left -X)
9	Y pot track backward
10	Y pot track wiper signal
11	Y pot track forward
12	Y pot track center tap
13	Y switch track common
14	Y switch track N/O (lever backward -Y)
15	X switch track N/O (lever right +X)
16	Y switch track center on

**J3 connector**

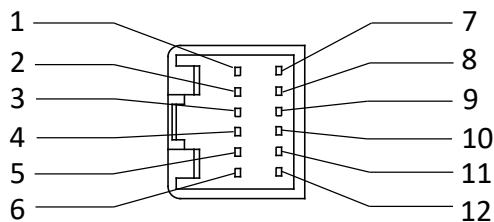

Pin	Function (Rocker)
1	Left switch backward
2	Left switch forward or horizontal left
3	-
4	-
5	Left output or horizontal output signal
6	Rocker center tap
7	Rocker positive power supply U+
8	-
9	-
10	Rocker negative power supply U-
11	Rocker switch common
12	-

Output characteristics

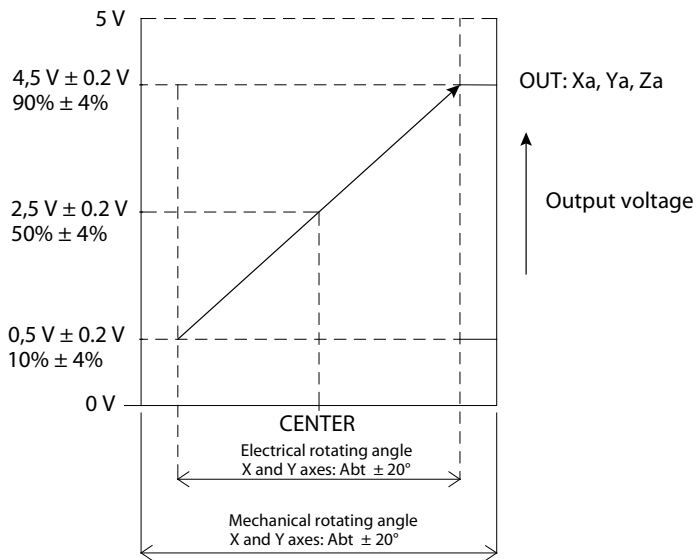

Each axes ⊖ direction ← | → Each axes ⊕ direction

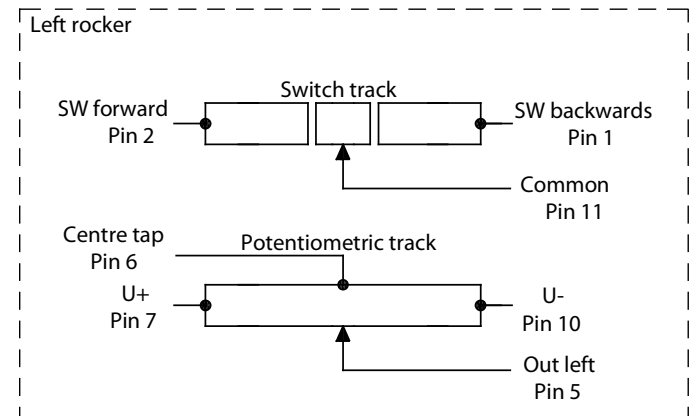
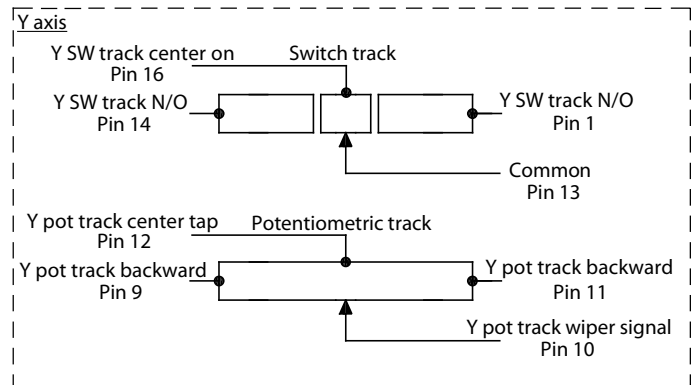
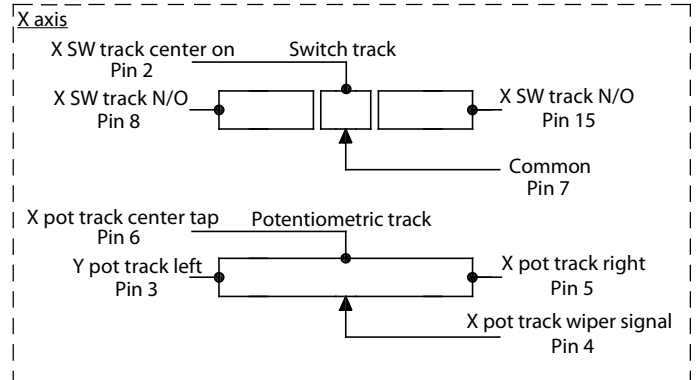



HYDRAULIC POWER CONTROL

**PEJD joystick controller multifunction grip - Right version**  
**Code number: PEJD2000LOD**  
**3 proportional axis**

<b>PERFORMANCE</b>		
<b>MECHANICAL</b>		
Lever operating force		
breakout*	N	7 or 16
operating*	N	19 or 39 (full deflection)
maximum allowable**	N	390 (490 overload)
Lever mechanical angle		
single axis only	°	±20 forward/reverse
square gate	°	±20 in X and Y directions
Seat		preferred bias on axis
Expected life		15 million operations (5 million for potentiometer track version)
Weight	g	750 without handle fitted
* Measured at 55mm above upper flange face		** Measured 130mm above upper flange face
<b>ENVIRONMENTAL</b>		
Operating temperature	°C	-25 to +80 (-25 to +80 with microswitches)
Storage temperature	°C	-25 to +85 (-25 to +85 with microswitches)
Environmental protection(above the flange) (above the flange)		IP66 IEC 60529 (fitted with HKN handle)
Vibration		Level ±3g,10Hz to 200Hz (random) @ 3.6g(rms)
Shock		20g, 6mS, half sine profile
EMC immunity level		100V/m, 30MHz to 1GHz, 1KHz 80% sine wave modulation, EN50082-2 (1995)
EMC emissions level		Complies with EN50081-2 (1993), 150kHz to 30MHz, level B
ESD immunity level		IEC61000-4-2 level 4 8kV contact discharge, 15kV air discharge
<b>ELECTRICAL – HALL EFFECT SENSOR</b>		
Resolution		Infinite
Supply voltage range	Vdc	5 ± 0.5 regulated transient free
Over voltage (maximum)	Vdc	15 continuous
Reverse polarity (maximum)	Vdc	14.5
Output voltage span - options	Vdc	±25% span - nominal 1.1 to 3.9
		±30% span - nominal 1.0 to 4.0
		±40% span - nominal 0.5 to 4.5
Load impedance (minimum)	kΩ	5
Center voltage (no load)	%	48 - 52 of supply voltage
Current consumption	mA	13 per axis (6.5 per sensor)
Insulation resistance		Greater than 50MΩ at 50Vdc
Output sense		The dual outputs rise together in the same direction, increasing with lever forward (and right), decreasing with lever backward (and left)
Output matching		See maximum output difference diagram below
<b>ELECTRICAL CONNECTIONS</b>		
Mating 12 way connector and pins		SA48061 (AMP 040 12 way connector 174045-2; pins 175062-1)
Mating 12 way harness		P49779 (connector, pins and 380mm long cable)



HYDRAULIC POWER CONTROL

**PEJD joystick controller multifunction grip - Right version**  
**Code number: PEJD2000LOD**  
**3 proportional axis**

<b>ELECTRICAL – POTENTIOMETER TRACK</b>		
Resolution		Virtually infinite
Track resistance ±20%	KΩ	1.8, 2, 2.9, 5
Track operating angle	°	±18
Output voltage range	%	0-100, 10-90, 25-75 of input
Center tap voltage	%	48 - 52 of applied voltage
Center tap angle	°	±2.5
Center tap to switch alignment	°	Within 0.5
Supply voltage maximum	Vdc	32
Wiper circuit impedance	MΩ	1 minimum recommended*
Power dissipation @ 25°C	W	0.25
Insulation resistance		Greater than 15MΩ at 50Vdc
* The long life resistive elements require a high impedance load in the wiper circuit to minimise the current flowing through the wiper for optimum life conditions		
<b>ELECTRICAL – DIRECTIONAL OR CENTER SWITCH (LOW CURRENT)</b>		
		Not available with CANbus output
Switch operating angle	°	1.5 or 5 either side of center
Supply voltage maximum	Vdc	35
Load current maximum	mA	200 resistive
<b>ELECTRICAL CONNECTIONS</b>		All primary potentiometer track and directional/center switch connections terminate in a 16-way AMP 040 series multi-lock connector in the joystick base. Secondary potentiometer track connections terminate in an 8-way AMP 040 series multi-lock connector.
Mating 16 way connector and pins		SA47931 (AMP 040 16 way connector 174046-2; Pins 175062-1)
Mating 16 way harness		P49780 (connector, pins and 380mm long cable)
Mating 8 way connector and pins		SA304522 (AMP 040 8 way connector 174044-2; pins 175062-1)
Mating 8 way harness		P303083 (connector, pins and 380mm long cable)
<b>ELECTRICAL MICROSWITCH</b>		
		Not available with CANbus output
Switch configuration		Two switches per axis Normally open at lever center position
Switch operating angle	°	2 to 5 either side of center
Contact rating		3A @125Vac, 2A @ 30Vdc
Switch life minimum		100,000 cycles, cycled at 1Hz, 1A and 12Vdc
Operating temperature	°C	-25 to +85

**PEJD joystick controller multifunction grip - Left version**  
Code number: **PEJD2000R0S**  
3 proportional axis

Forward orientation indent  
(orientation mark, Y axis)

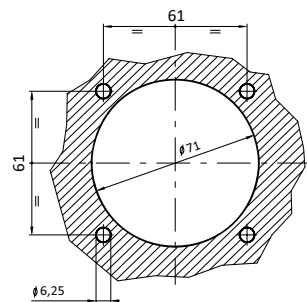
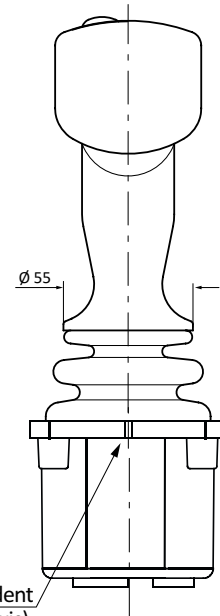
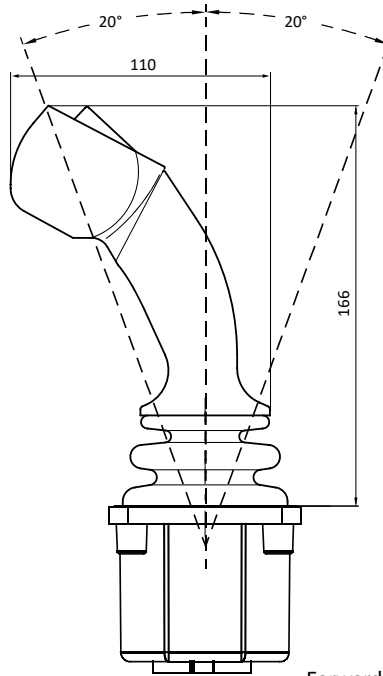
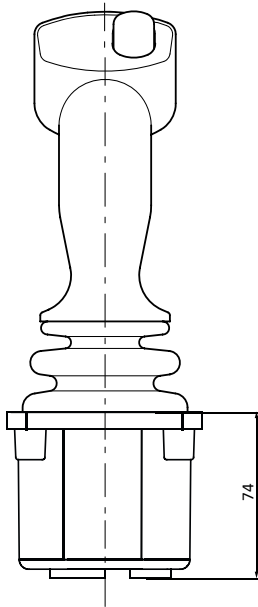
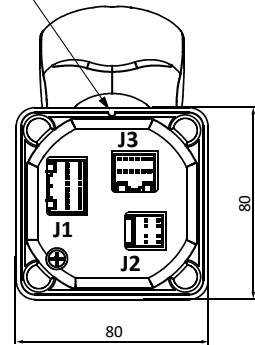

Panel mounting details

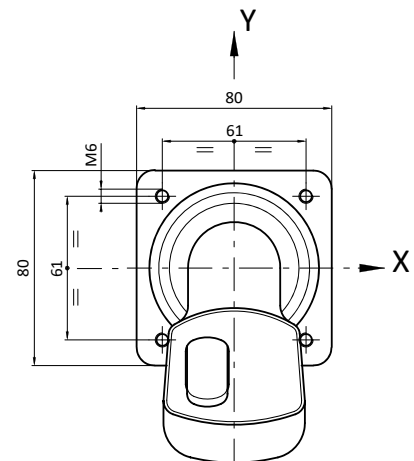



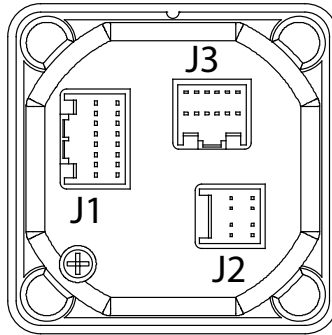

**J1 connector**

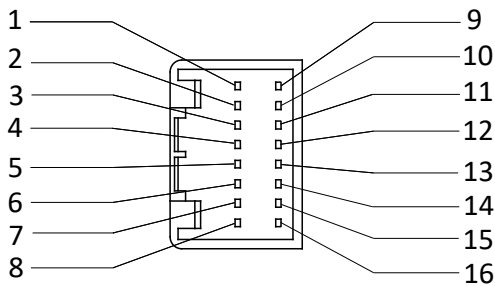

Pin	Function (potentiometer)
1	Y switch track N/O (lever forward +Y)
2	X switch track center on
3	X pot track left
4	X pot track wiper signal
5	X pot track right
6	X pot track center tap
7	X switch track common
8	X switch track N/O (lever left -X)
9	Y pot track backward
10	Y pot track wiper signal
11	Y pot track forward
12	Y pot track center tap
13	Y switch track common
14	Y switch track N/O (lever backward -Y)
15	X switch track N/O (lever right +X)
16	Y switch track center on

**J3 connector**

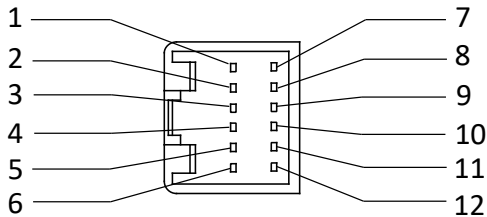

Pin	Function (Rocker)
1	-
2	-
3	Right switch forward
4	Right switch backward
5	-
6	Rocker center tap
7	Rocker positive power supply U+
8	-
9	Right output signal
10	Rocker negative power supply U-
11	Rocker switch common
12	-

Output characteristics

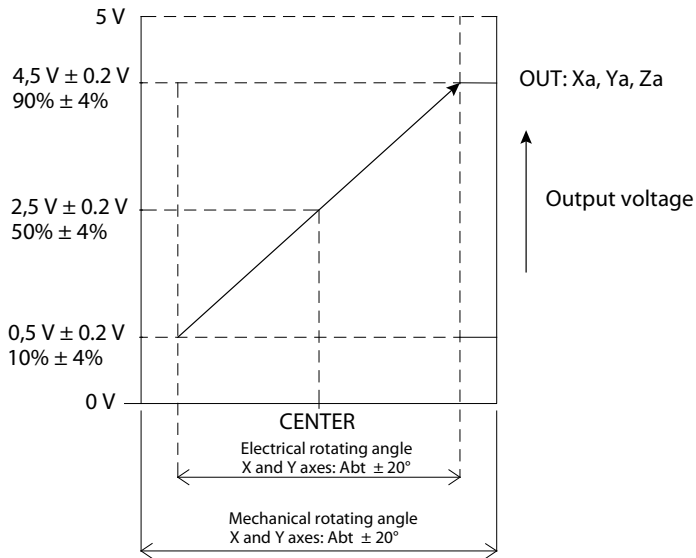

Each axes ⊖ direction ← | → Each axes ⊕ direction

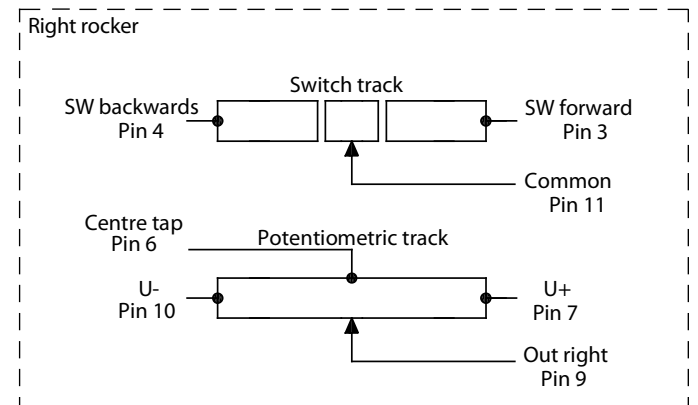
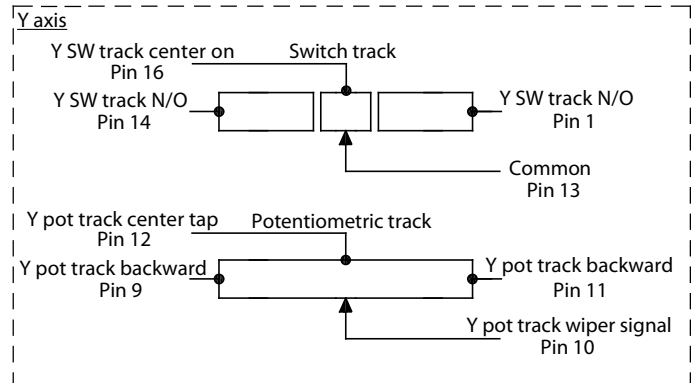
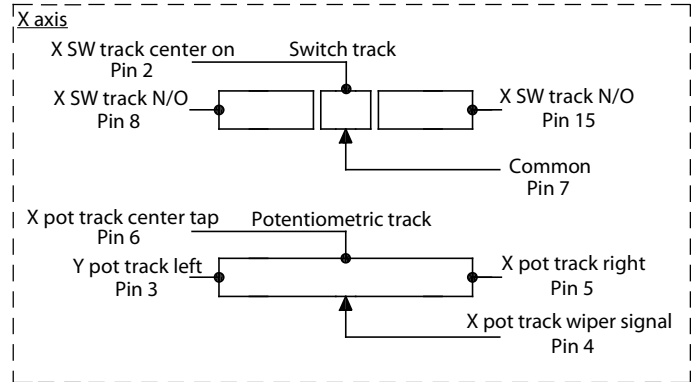



HYDRAULIC POWER CONTROL

**PEJD** joystick controller multifunction grip - Left version  
 Code number: **PEJD2000R0S**  
 3 proportional axis

<b>PERFORMANCE</b>		
<b>MECHANICAL</b>		
Lever operating force		
breakout*	N	7 or 16
operating*	N	19 or 39 (full deflection)
maximum allowable**	N	390 (490 overload)
Lever mechanical angle		
single axis only	°	±20 forward/reverse
square gate	°	±20 in X and Y directions
Seat		preferred bias on axis
Expected life		15 million operations (5 million for potentiometer track version)
Weight	g	750 without handle fitted
* Measured at 55mm above upper flange face		** Measured 130mm above upper flange face
<b>ENVIRONMENTAL</b>		
Operating temperature	°C	-25 to +80 (-25 to +80 with microswitches)
Storage temperature	°C	-25 to +85 (-25 to +85 with microswitches)
Environmental protection(above the flange) (above the flange)		IP66 IEC 60529 (fitted with HKN handle)
Vibration		Level ±3g,10Hz to 200Hz (random) @ 3.6g(rms)
Shock		20g, 6mS, half sine profile
EMC immunity level		100V/m, 30MHz to 1GHz, 1KHz 80% sine wave modulation, EN50082-2 (1995)
EMC emissions level		Complies with EN50081-2 (1993), 150kHz to 30MHz, level B
ESD immunity level		IEC61000-4-2 level 4 8kV contact discharge, 15kV air discharge
<b>ELECTRICAL – HALL EFFECT SENSOR</b>		
Resolution		Infinite
Supply voltage range	Vdc	5 ± 0.5 regulated transient free
Over voltage (maximum)	Vdc	15 continuous
Reverse polarity (maximum)	Vdc	14.5
Output voltage span - options	Vdc	±25% span - nominal 1.1 to 3.9
		±30% span - nominal 1.0 to 4.0
		±40% span - nominal 0.5 to 4.5
Load impedance (minimum)	kΩ	5
Center voltage (no load)	%	48 - 52 of supply voltage
Current consumption	mA	13 per axis (6.5 per sensor)
Insulation resistance		Greater than 50MΩ at 50Vdc
Output sense		The dual outputs rise together in the same direction, increasing with lever forward (and right), decreasing with lever backward (and left)
Output matching		See maximum output difference diagram below
<b>ELECTRICAL CONNECTIONS</b>		
Mating 12 way connector and pins		SA48061 (AMP 040 12 way connector 174045-2; pins 175062-1)
Mating 12 way harness		P49779 (connector, pins and 380mm long cable)



HYDRAULIC POWER CONTROL

**PEJD joystick controller multifunction grip - Left version**  
**Code number: PEJD2000R0S**  
**3 proportional axis**

<b>ELECTRICAL – POTENTIOMETER TRACK</b>		
Resolution		Virtually infinite
Track resistance ±20%	KΩ	1.8, 2, 2.9, 5
Track operating angle	°	±18
Output voltage range	%	0-100, 10-90, 25-75 of input
Center tap voltage	%	48 - 52 of applied voltage
Center tap angle	°	±2.5
Center tap to switch alignment	°	Within 0.5
Supply voltage maximum	Vdc	32
Wiper circuit impedance	MΩ	1 minimum recommended*
Power dissipation @ 25°C	W	0.25
Insulation resistance		Greater than 15MΩ at 50Vdc
* The long life resistive elements require a high impedance load in the wiper circuit to minimise the current flowing through the wiper for optimum life conditions		
<b>ELECTRICAL – DIRECTIONAL OR CENTER SWITCH (LOW CURRENT)</b>		
		Not available with CANbus output
Switch operating angle	°	1.5 or 5 either side of center
Supply voltage maximum	Vdc	35
Load current maximum	mA	200 resistive
<b>ELECTRICAL CONNECTIONS</b>		
All primary potentiometer track and directional/center switch connections terminate in a 16-way AMP 040 series multi-lock connector in the joystick base. Secondary potentiometer track connections terminate in an 8-way AMP 040 series multi-lock connector.		
Mating 16 way connector and pins		SA47931 (AMP 040 16 way connector 174046-2; Pins 175062-1)
Mating 16 way harness		P49780 (connector, pins and 380mm long cable)
Mating 8 way connector and pins		SA304522 (AMP 040 8 way connector 174044-2; pins 175062-1)
Mating 8 way harness		P303083 (connector, pins and 380mm long cable)
<b>ELECTRICAL MICROSWITCH</b>		
		Not available with CANbus output
Switch configuration		Two switches per axis Normally open at lever center position
Switch operating angle	°	2 to 5 either side of center
Contact rating		3A @125Vac, 2A @ 30Vdc
Switch life minimum		100,000 cycles, cycled at 1Hz, 1A and 12Vdc
Operating temperature	°C	-25 to +85

**PEJD** joystick controller multifunction grip  
Code number: **PEJD2000000**  
2 proportional axis

Forward orientation indent  
(orientation mark, Y axis)

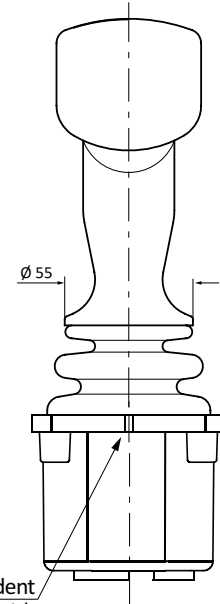
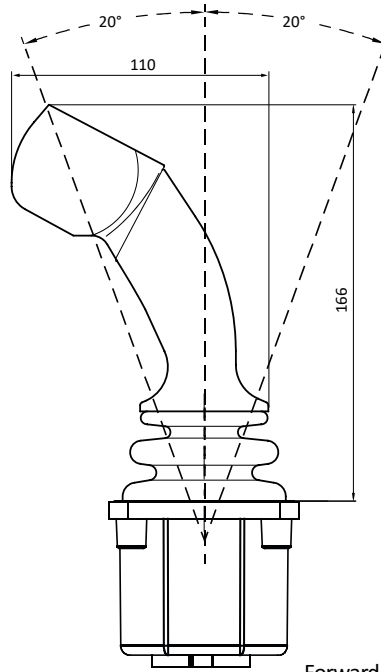
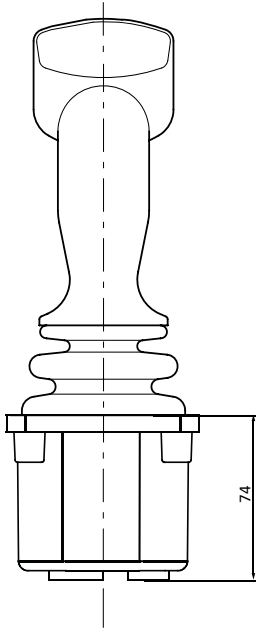
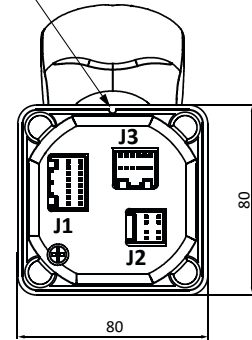

Forward orientation indent  
(orientation mark, Y axis)

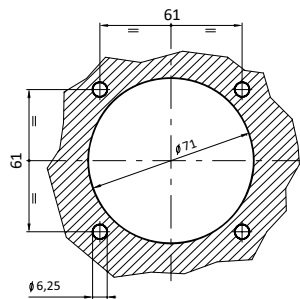

Panel mounting details

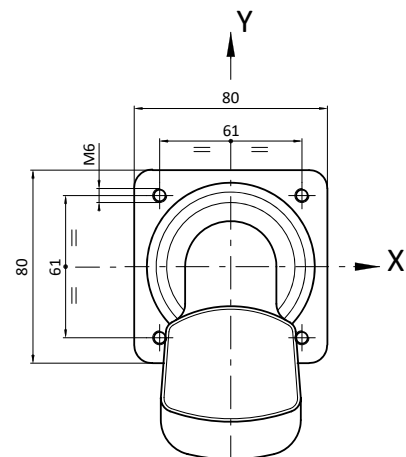

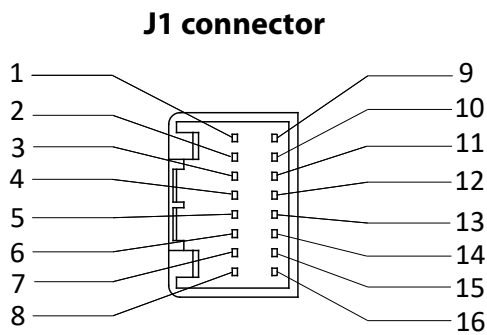
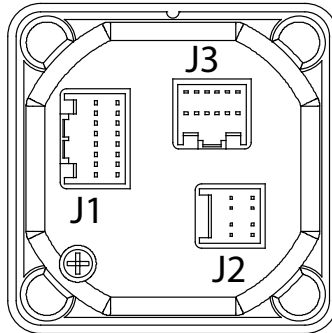

Pin	Function (potentiometer)
1	Y switch track N/O (lever forward +Y)
2	X switch track center on
3	X pot track left
4	X pot track wiper signal
5	X pot track right
6	X pot track center tap
7	X switch track common
8	X switch track N/O (lever left -X)
9	Y pot track backward
10	Y pot track wiper signal
11	Y pot track forward
12	Y pot track center tap
13	Y switch track common
14	Y switch track N/O (lever backward -Y)
15	X switch track N/O (lever right +X)
16	Y switch track center on

Output characteristics

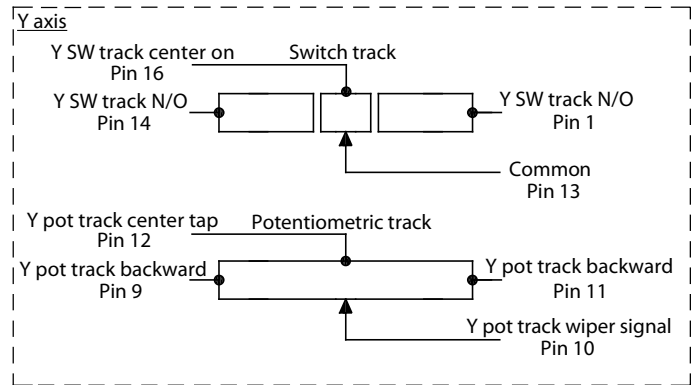
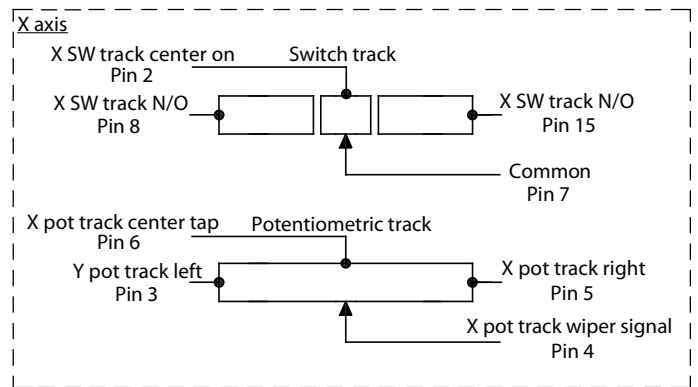
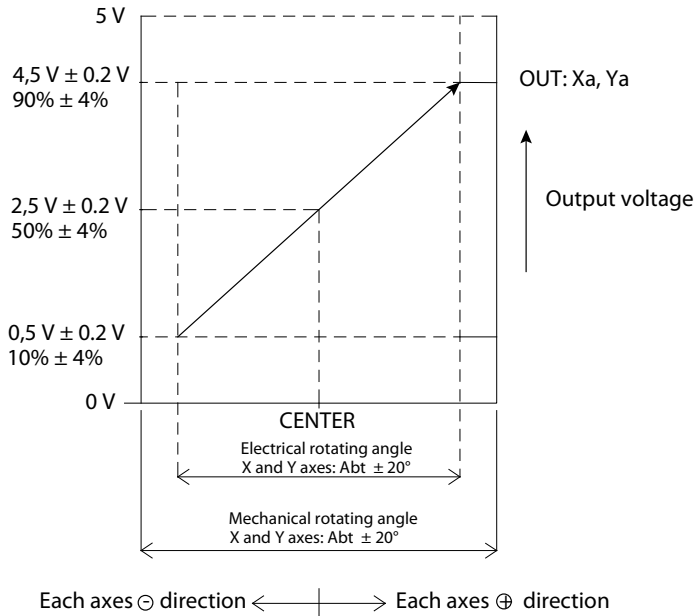



HYDRAULIC POWER CONTROL

**PEJD joystick controller multifunction grip**

Code number: **PEJD200000**

2 proportional axis

<b>PERFORMANCE</b>		
<b>MECHANICAL</b>		
Lever operating force		
breakout*	N	7 or 16
operating*	N	19 or 39 (full deflection)
maximum allowable**	N	390 (490 overload)
Lever mechanical angle		
single axis only	°	±20 forward/reverse
square gate	°	±20 in X and Y directions
Seat		preferred bias on axis
Expected life		15 million operations (5 million for potentiometer track version)
Weight	g	750 without handle fitted
* Measured at 55mm above upper flange face		** Measured 130mm above upper flange face
<b>ENVIRONMENTAL</b>		
Operating temperature	°C	-25 to +80 (-25 to +80 with microswitches)
Storage temperature	°C	-25 to +85 (-25 to +85 with microswitches)
Environmental protection(above the flange) (above the flange)		IP66 IEC 60529 (fitted with HKN handle)
Vibration		Level ±3g,10Hz to 200Hz (random) @ 3.6g(rms)
Shock		20g, 6mS, half sine profile
EMC immunity level		100V/m, 30MHz to 1GHz, 1KHz 80% sine wave modulation, EN50082-2 (1995)
EMC emissions level		Complies with EN50081-2 (1993), 150kHz to 30MHz, level B
ESD immunity level		IEC61000-4-2 level 4 8kV contact discharge, 15kV air discharge
<b>ELECTRICAL – HALL EFFECT SENSOR</b>		
Resolution		Infinite
Supply voltage range	Vdc	5 ± 0.5 regulated transient free
Over voltage (maximum)	Vdc	15 continuous
Reverse polarity (maximum)	Vdc	14.5
Output voltage span - options	Vdc	±25% span - nominal 1.1 to 3.9
		±30% span - nominal 1.0 to 4.0
		±40% span - nominal 0.5 to 4.5
Load impedance (minimum)	kΩ	5
Center voltage (no load)	%	48 - 52 of supply voltage
Current consumption	mA	13 per axis (6.5 per sensor)
Insulation resistance		Greater than 50MΩ at 50Vdc
Output sense		The dual outputs rise together in the same direction, increasing with lever forward (and right), decreasing with lever backward (and left)
Output matching		See maximum output difference diagram below
<b>ELECTRICAL CONNECTIONS</b>		
Mating 12 way connector and pins		SA48061 (AMP 040 12 way connector 174045-2; pins 175062-1)
Mating 12 way harness		P49779 (connector, pins and 380mm long cable)





HYDRAULIC POWER CONTROL

**PEJD joystick controller multifunction grip**  
 Code number: **PEJD2000000**  
 2 proportional axis

<b>ELECTRICAL – POTENTIOMETER TRACK</b>		
Resolution		Virtually infinite
Track resistance ±20%	KΩ	1.8, 2, 2.9, 5
Track operating angle	°	±18
Output voltage range	%	0-100, 10-90, 25-75 of input
Center tap voltage	%	48 - 52 of applied voltage
Center tap angle	°	±2.5
Center tap to switch alignment	°	Within 0.5
Supply voltage maximum	Vdc	32
Wiper circuit impedance	MΩ	1 minimum recommended*
Power dissipation @ 25°C	W	0.25
Insulation resistance		Greater than 15MΩ at 50Vdc
* The long life resistive elements require a high impedance load in the wiper circuit to minimise the current flowing through the wiper for optimum life conditions		
<b>ELECTRICAL – DIRECTIONAL OR CENTER SWITCH (LOW CURRENT)</b>		
		Not available with CANbus output
Switch operating angle	°	1.5 or 5 either side of center
Supply voltage maximum	Vdc	35
Load current maximum	mA	200 resistive
<b>ELECTRICAL CONNECTIONS</b>		All primary potentiometer track and directional/center switch connections terminate in a 16-way AMP 040 series multi-lock connector in the joystick base. Secondary potentiometer track connections terminate in an 8-way AMP 040 series multi-lock connector.
Mating 16 way connector and pins		SA47931 (AMP 040 16 way connector 174046-2; Pins 175062-1)
Mating 16 way harness		P49780 (connector, pins and 380mm long cable)
Mating 8 way connector and pins		SA304522 (AMP 040 8 way connector 174044-2; pins 175062-1)
Mating 8 way harness		P303083 (connector, pins and 380mm long cable)
<b>ELECTRICAL MICROSWITCH</b>		
		Not available with CANbus output
Switch configuration		Two switches per axis Normally open at lever center position
Switch operating angle	°	2 to 5 either side of center
Contact rating		3A @125Vac, 2A @ 30Vdc
Switch life minimum		100,000 cycles, cycled at 1Hz, 1A and 12Vdc
Operating temperature	°C	-25 to +85

**PEJD** double axis proportional joystick  
code number: **PEJD40060D0**  
with person present switch and six on-off push button switch

Forward orientation indent  
(orientation mark, Y axis)

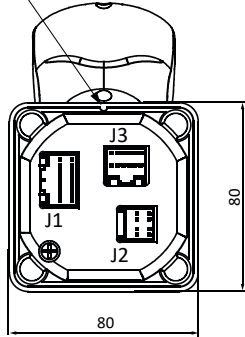

6 on-off push  
button switch

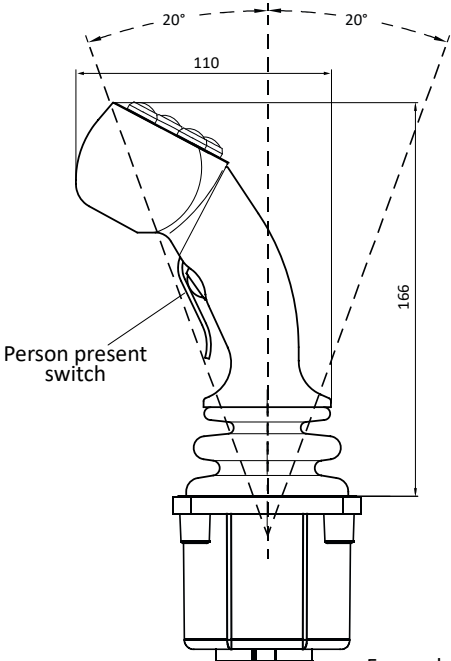
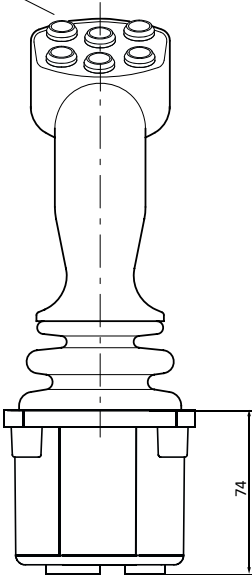

Forward orientation indent  
(orientation mark, Y axis)

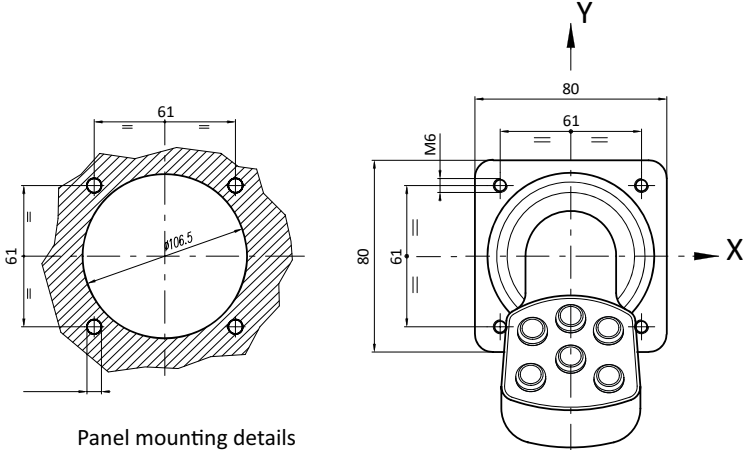
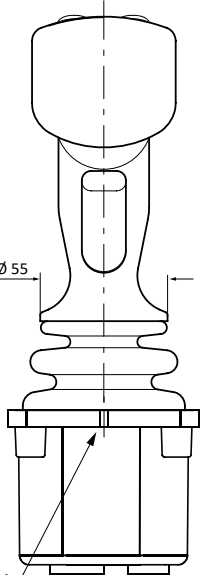

Panel mounting details

**PEJD** double axis proportional joystick

code number: **PEJD40060D0**

with person present switch and six on-off push button switch

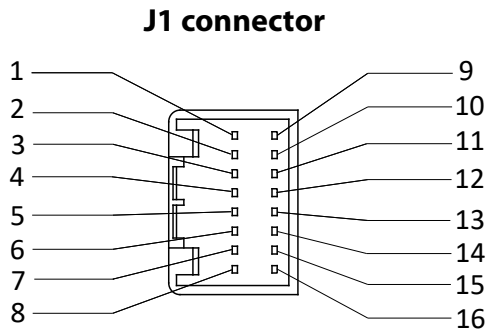
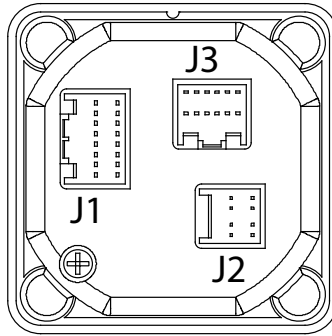

Pin	Function (potentiometer)
1	Y switch track N/O (lever forward +Y)
2	X switch track center on
3	X pot track left
4	X pot track wiper signal
5	X pot track right
6	X pot track center tap
7	X switch track common
8	X switch track N/O (lever left -X)
9	Y pot track backward
10	Y pot track wiper signal
11	Y pot track forward
12	Y pot track center tap
13	Y switch track common
14	Y switch track N/O (lever backward -Y)
15	X switch track N/O (lever right +X)
16	Y switch track center on

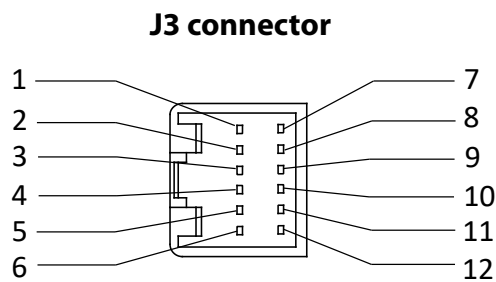

Pin	Function (Rocker)
1	Left switch backward
2	Left switch forward or horizontal left
3	-
4	-
5	Left output or horizontal output signal
6	Rocker center tap
7	Rocker positive power supply U+
8	-
9	-
10	Rocker negative power supply U-
11	Rocker switch common
12	-

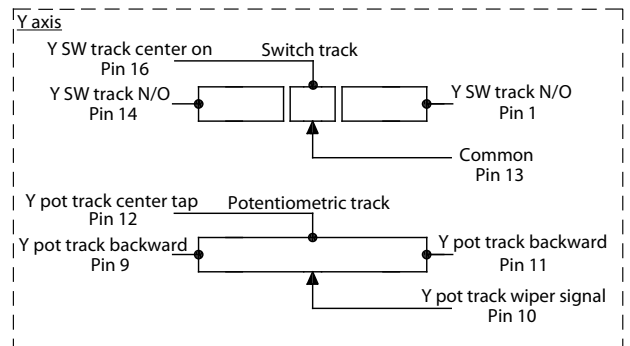
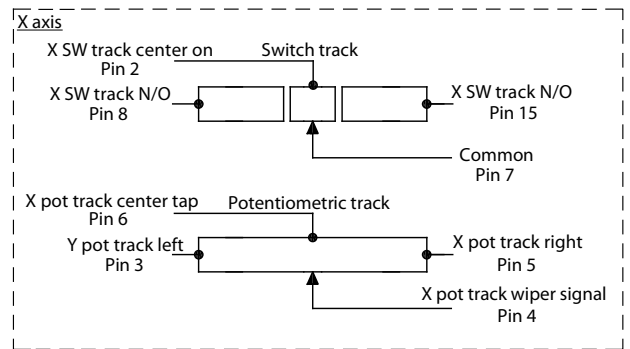
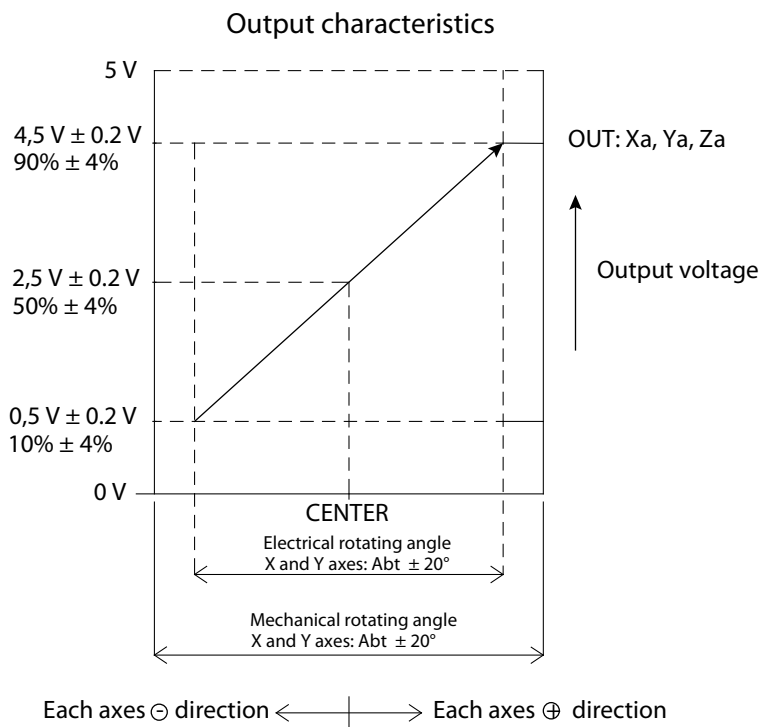



HYDRAULIC POWER CONTROL

**PEJD** double axis proportional joystick

code number: **PEJD40060D0**

with person present switch and six on-off push button switch

PERFORMANCE		
<b>MECHANICAL</b>		
Lever operating force		
breakout*	N	7 or 16
operating*	N	19 or 39 (full deflection)
maximum allowable**	N	390 (490 overload)
Lever mechanical angle		
single axis only	°	±20 forward/reverse
square gate	°	±20 in X and Y directions
Seat		preferred bias on axis
Expected life		15 million operations (5 million for potentiometer track version)
Weight	g	750 without handle fitted
* Measured at 55mm above upper flange face		** Measured 130mm above upper flange face
<b>ENVIRONMENTAL</b>		
Operating temperature	°C	-25 to +80 (-25 to +80 with microswitches)
Storage temperature	°C	-25 to +85 (-25 to +85 with microswitches)
Environmental protection(above the flange) (above the flange)		IP66 IEC 60529 (fitted with HKN handle)
Vibration		Level ±3g,10Hz to 200Hz (random) @ 3.6g(rms)
Shock		20g, 6mS, half sine profile
EMC immunity level		100V/m, 30MHz to 1GHz, 1KHz 80% sine wave modulation, EN50082-2 (1995)
EMC emissions level		Complies with EN50081-2 (1993), 150kHz to 30MHz, level B
ESD immunity level		IEC61000-4-2 level 4 8kV contact discharge, 15kV air discharge
<b>ELECTRICAL – HALL EFFECT SENSOR</b>		
Resolution		Infinite
Supply voltage range	Vdc	5 ± 0.5 regulated transient free
Over voltage (maximum)	Vdc	15 continuous
Reverse polarity (maximum)	Vdc	14.5
Output voltage span - options	Vdc	±25% span - nominal 1.1 to 3.9
		±30% span - nominal 1.0 to 4.0
		±40% span - nominal 0.5 to 4.5
Load impedance (minimum)	kΩ	5
Center voltage (no load)	%	48 - 52 of supply voltage
Current consumption	mA	13 per axis (6.5 per sensor)
Insulation resistance		Greater than 50MΩ at 50Vdc
Output sense		The dual outputs rise together in the same direction, increasing with lever forward (and right), decreasing with lever backward (and left)
Output matching		See maximum output difference diagram below
<b>ELECTRICAL CONNECTIONS</b>		
Mating 12 way connector and pins		SA48061 (AMP 040 12 way connector 174045-2; pins 175062-1)
Mating 12 way harness		P49779 (connector, pins and 380mm long cable)



HYDRAULIC POWER CONTROL

PEJD double axis proportional joystick

code number: PEJD40060D0

with person present switch and six on-off push button switch

<b>ELECTRICAL – POTENTIOMETER TRACK</b>		
Resolution		Virtually infinite
Track resistance $\pm 20\%$	K $\Omega$	1.8, 2, 2.9, 5
Track operating angle	°	$\pm 18$
Output voltage range	%	0-100, 10-90, 25-75 of input
Center tap voltage	%	48 - 52 of applied voltage
Center tap angle	°	$\pm 2.5$
Center tap to switch alignment	°	Within 0.5
Supply voltage maximum	Vdc	32
Wiper circuit impedance	M $\Omega$	1 minimum recommended*
Power dissipation @ 25°C	W	0.25
Insulation resistance		Greater than 15M $\Omega$ at 50Vdc
* The long life resistive elements require a high impedance load in the wiper circuit to minimise the current flowing through the wiper for optimum life conditions		
<b>ELECTRICAL – DIRECTIONAL OR CENTER SWITCH (LOW CURRENT)</b>		
Not available with CANbus output		
Switch operating angle	°	1.5 or 5 either side of center
Supply voltage maximum	Vdc	35
Load current maximum	mA	200 resistive
<b>ELECTRICAL CONNECTIONS</b>		
All primary potentiometer track and directional/center switch connections terminate in a 16-way AMP 040 series multi-lock connector in the joystick base. Secondary potentiometer track connections terminate in an 8-way AMP 040 series multi-lock connector.		
Mating 16 way connector and pins		SA47931 (AMP 040 16 way connector 174046-2; Pins 175062-1)
Mating 16 way harness		P49780 (connector, pins and 380mm long cable)
Mating 8 way connector and pins		SA304522 (AMP 040 8 way connector 174044-2; pins 175062-1)
Mating 8 way harness		P303083 (connector, pins and 380mm long cable)
<b>ELECTRICAL MICROSWITCH</b>		
Not available with CANbus output		
Switch configuration		Two switches per axis Normally open at lever center position
Switch operating angle	°	. 2 to 5 either side of
Contact rating		center 3A @125Vac, 2A @ 30Vdc
Switch life minimum		100,000 cycles, cycled at 1Hz, 1A and 12Vdc
Operating temperature	°C	-25 to +85
<b>ELECTRICAL CONNECTIONS</b>		
Microswitch connections in the potentiometer joystick will replace the low current directional/center switches in the 16-way AMP 040 series multi-lock connector in the joystick base. In the Hall sensor joystick, switches terminate in the 8-way connector.		
<b>CAN OUTPUT VERSION</b>		
J6000 with Hall sensing option can also be supplied with an integrated CANBUS output offering the J1939 protocol. This CANBUS interface meets the requirements of IEC61508 SIL level 1		
Supply voltage range	Vdc	9 to 36
CAN version		CAN 2.0b
Protocol		J1939
Under-panel sealing		IP66 IEC60529
<b>ELECTRICAL CONNECTIONS</b>		
Mating connector and pins		All connections terminate in the 6-way Deutsch DTM04-6P integrated connector P304844 (includes 390mm flying leads)

Алматы (7273)495-231  
 Ангарск (3955)60-70-56  
 Архангельск (8182)63-90-72  
 Астрахань (8512)99-46-04  
 Барнаул (3852)73-04-60  
 Белгород (4722)40-23-64  
 Благовещенск (4162)22-76-07  
 Брянск (4832)59-03-52  
 Владивосток (423)249-28-31  
 Владикавказ (8672)28-90-48  
 Владимир (4922)49-43-18  
 Волгоград (844)278-03-48  
 Вологда (8172)26-41-59  
 Воронеж (473)204-51-73  
 Екатеринбург (343)384-55-89

Иваново (4932)77-34-06  
 Ижевск (3412)26-03-58  
 Иркутск (395)279-98-46  
 Казань (843)206-01-48  
 Калининград (4012)72-03-81  
 Калуга (4842)92-23-67  
 Кемерово (3842)65-04-62  
 Киров (8332)68-02-04  
 Коломна (4966)23-41-49  
 Кострома (4942)77-07-48  
 Краснодар (861)203-40-90  
 Красноярск (391)204-63-61  
 Курск (4712)77-13-04  
 Курган (3522)50-90-47  
 Липецк (4742)52-20-81

Магнитогорск (3519)55-03-13  
 Москва (495)268-04-70  
 Мурманск (8152)59-64-93  
 Набережные Челны (8552)20-53-41  
 Нижний Новгород (831)429-08-12  
 Новокузнецк (3843)20-46-81  
 Ноябрьск (3496)41-32-12  
 Новосибирск (383)227-86-73  
 Омск (3812)21-46-40  
 Орел (4862)44-53-42  
 Оренбург (3532)37-68-04  
 Пенза (8412)22-31-16  
 Петрозаводск (8142)55-98-37  
 Псков (8112)59-10-37  
 Пермь (342)205-81-47

Ростов-на-Дону (863)308-18-15  
 Рязань (4912)46-61-64  
 Самара (846)206-03-16  
 Санкт-Петербург (812)309-46-40  
 Саратов (845)249-38-78  
 Севастополь (8692)22-31-93  
 Саранск (8342)22-96-24  
 Симферополь (3652)67-13-56  
 Смоленск (4812)29-41-54  
 Сочи (862)225-72-31  
 Ставрополь (8652)20-65-13  
 Сургут (3462)77-98-35  
 Сыктывкар (8212)25-95-17  
 Тамбов (4752)50-40-97  
 Тверь (4822)63-31-35

Тольятти (8482)63-91-07  
 Томск (3822)98-41-53  
 Тула (4872)33-79-87  
 Тюмень (3452)66-21-18  
 Ульяновск (8422)24-23-59  
 Улан-Удэ (3012)59-97-51  
 Уфа (347)229-48-12  
 Хабаровск (4212)92-98-04  
 Чебоксары (8352)28-53-07  
 Челябинск (351)202-03-61  
 Череповец (8202)49-02-64  
 Чита (3022)38-34-83  
 Якутск (4112)23-90-97  
 Ярославль (4852)69-52-93

Россия +7(495)268-04-70

Казахстан +7(7172)727-132

Киргизия +996(312)96-26-47